

BELLSOUTH® / CLEC Agreement

Customer Name: ComSouth Telenet, Inc.

ComSouth Telenet 3Q06 TRRO Compliant Interconnection Agreement for GA only	2
Table of Contents	3
General Terms and Conditions	5
Signature Page	25
Att 1 - Resale	26
Att 1 - Resale Discounts & Rates	44
Att 2 - Other Services	45
Att 2 - Other Services Rates - Exhibit A	50
Att 3 - Network Interconnection	52
Att 3 - Local Interconnection Rates	82
Att 4 - Collocation	84
Att 4 - Collocation Rates - Exhibit B	134
Att 5 - Access to Numbers and Number Portability	139
Att 6 - Ordering	144
Att 7 - Billing	153
Att 8 - Rights of Way	164
Att 9 - Service Quality Measurements	166
Att 10 - Disaster Recovery Plan	168
Att 11 - BFR and NBR Process	177

Interconnection Agreement
Between
BellSouth Telecommunications, Inc.
and
ComSouth Telenet, Inc.

TABLE OF CONTENTS

General Terms and Conditions

Definitions

- 1. CLEC Certification**
- 2. Term of the Agreement**
- 3. Nondiscriminatory Access**
- 4. Court Ordered Requests for Call Detail Records and Other Subscriber Information**
- 5. Liability and Indemnification**
- 6. Intellectual Property Rights and Indemnification**
- 7. Proprietary and Confidential Information**
- 8. Resolution of Disputes**
- 9. Taxes**
- 10. Force Majeure**
- 11. Adoption of Agreements**
- 12. Modification of Agreement**
- 13. Legal Rights**
- 14. Indivisibility**
- 15. Severability**
- 16. Non-Waivers**
- 17. Governing Law**
- 18. Assignments and Transfers**
- 19. Notices**
- 20. Rule of Construction**
- 21. Headings of No Force or Effect**
- 22. Multiple Counterparts**
- 23. Filing of Agreement**
- 24. Compliance with Law**
- 25. Necessary Approvals**
- 26. Good Faith Performance**
- 27. Rates**
- 28. Rate True-Up**
- 29. Survival**
- 30. Entire Agreement**

TABLE OF CONTENTS (cont'd)

Attachment 1 - Resale

Attachment 3 - Network Interconnection

Attachment 4 - Collocation

Attachment 5 - Access to Numbers and Number Portability

Attachment 6 – Pre-Ordering, Ordering, Provisioning and Maintenance and Repair

Attachment 7 - Billing

Attachment 8 - Rights-of-Way, Conduits and Pole Attachments

Attachment 9 – Service Quality Measurements

Attachment 10- BellSouth Disaster Recovery Plan

Attachment 11–Bona Fide Request and New Business Request Process

AGREEMENT GENERAL TERMS AND CONDITIONS

THIS AGREEMENT is made by and between BellSouth Telecommunications, Inc., (BellSouth), a Georgia corporation, and ComSouth Telenet, Inc. (ComSouth), a Georgia corporation, and shall be effective on the Effective Date, as defined herein. This Agreement may refer to either BellSouth or ComSouth or both as a “Party” or “Parties.”

W I T N E S S E T H

WHEREAS, BellSouth is a local exchange telecommunications company authorized to provide Telecommunications Services (as defined below) in the states of Alabama, Florida, Georgia, Kentucky, Louisiana, Mississippi, North Carolina, South Carolina and Tennessee; and

WHEREAS, ComSouth is or seeks to become a CLEC authorized to provide telecommunications services in the state of Georgia; and

WHEREAS, pursuant to Sections 251 and 252 of the Act; ComSouth wishes to purchase certain services from BellSouth; and

WHEREAS, the Parties wish to interconnect their facilities, exchange traffic, and perform Local Number Portability (LNP) pursuant to Sections 251 and 252 of the Act as set forth herein; and

WHEREAS, ComSouth wishes to purchase and BellSouth wishes to provide other services as described in this Agreement;

NOW THEREFORE, in consideration of the mutual agreements contained herein, BellSouth and ComSouth agree as follows:

Definitions

Affiliate is defined as a person that (directly or indirectly) owns or controls, is owned or controlled by, or is under common ownership or control with, another person. For purposes of this paragraph, the term “own” means to own an equity interest (or equivalent thereof) of more than ten percent (10%).

Commission is defined as the Georgia Public Service Commission.

Competitive Local Exchange Carrier (CLEC) means a telephone company certificated by the Commission to provide local exchange service within BellSouth's franchised area.

Effective Date is defined as the date that the Agreement is effective for purposes of rates, terms and conditions and shall be thirty (30) days after the date of the last signature executing the Agreement. Future amendments for rate changes will also be effective thirty (30) days after the date of the last signature executing the amendment.

FCC means the Federal Communications Commission.

Telecommunications means the transmission, between or among points specified by the user, of information of the user's choosing, without change in the form or content of the information as sent and received.

Telecommunications Service means the offering of telecommunications for a fee directly to the public, or to such classes of users as to be effectively available directly to the public, regardless of the facilities used.

Telecommunications Act of 1996 (Act) means Public Law 104-104 of the United States Congress effective February 8, 1996. The Act amended the Communications Act of 1934 (47 U.S.C. Section 1 et. seq.).

1 CLEC Certification

- 1.1 ComSouth agrees to provide BellSouth in writing ComSouth's CLEC certification from the Commission for the state of Georgia prior to BellSouth filing this Agreement with the appropriate Commission for approval. Additionally, ComSouth shall provide to BellSouth an effective certification to do business issued by the secretary of state or equivalent authority in each state covered by this Agreement.
- 1.2 To the extent ComSouth is not certified as a CLEC in each state covered by this Agreement as of the execution hereof, ComSouth may not purchase services hereunder in that state. ComSouth will notify BellSouth in writing and provide CLEC certification from the Commission when it becomes certified to operate in, as well as an effective certification to do business issued by the secretary of state or equivalent authority for, any other state covered by this Agreement. Upon receipt thereof, BellSouth will file this Agreement in that state, and ComSouth may purchase services pursuant to this Agreement in that state, subject to establishing appropriate accounts in the additional state as described in Attachment 7.
- 1.3 Should ComSouth's Commission/CLEC certification in any state be rescinded or otherwise terminated, BellSouth may, at its election, suspend or terminate this Agreement immediately and all monies owed on all outstanding invoices for services provided in that state shall become due, or BellSouth may refuse to provide services hereunder in that state until Commission/CLEC certification is reinstated in that state, provided such notification is made prior to expiration of the term of this Agreement. Additionally, once Commission//CLEC certification is

reinstated, ComSouth shall again provide an effective certification to do business issued by the secretary of state or equivalent authority in each state covered by this Agreement.

2 Term of the Agreement

- 2.1 The initial term of this Agreement shall be three (3) years, beginning on the Effective Date and shall apply to the BellSouth territory in the state of Georgia. Notwithstanding any prior agreement of the Parties, the rates, terms and conditions of this Agreement shall not be applied retroactively prior to the Effective Date.
- 2.2 The Parties agree that by no earlier than two hundred seventy (270) days and no later than one hundred eighty (180) days prior to the expiration of the initial term of this Agreement, the Parties shall commence negotiations for a new agreement to be effective beginning on the expiration date of this Agreement (Subsequent Agreement). If as of the expiration of the initial term of this Agreement, a Subsequent Agreement has not been executed by the Parties, then except as set forth in Sections 2.3.1 and 2.3.2 below, this Agreement shall continue on a month-to-month basis while a Subsequent Agreement is being negotiated. The Parties' rights and obligations with respect to this Agreement after expiration of the initial term shall be as set forth in Section 2.3 below.
- 2.3 If, within one hundred thirty-five (135) days of commencing the negotiation referred to in Section 2.2 above, the Parties are unable to negotiate new terms, conditions and prices for a Subsequent Agreement, either Party may petition the Commission to establish appropriate rates, terms and conditions for the Subsequent Agreement pursuant to 47 U.S.C. § 252.
- 2.3.1 ComSouth may request termination of this Agreement only if it is no longer purchasing services pursuant to this Agreement. Except as set forth in Section 2.3.2 below, notwithstanding the foregoing, in the event that as of the date of expiration of the initial term of this Agreement and conversion of this Agreement to a month-to-month term, the Parties have not entered into a Subsequent Agreement and no arbitration proceeding has been filed in accordance with Section 2.3 above, then BellSouth may terminate this Agreement upon sixty (60) days notice to ComSouth. In the event that BellSouth terminates this Agreement as provided above, BellSouth shall continue to offer services to ComSouth pursuant to the rates, terms and conditions set forth in BellSouth's then current standard interconnection agreement. In the event that BellSouth's standard interconnection agreement becomes effective between the Parties, the Parties may continue to negotiate a Subsequent Agreement.
- 2.3.2 Notwithstanding Section 2.2 above, in the event that as of the expiration of the initial term of this Agreement the Parties have not entered into a Subsequent Agreement and no arbitration proceeding has been filed in accordance with Section 2.3 above and BellSouth is not providing any services under this Agreement as of the date of expiration of the initial term of this Agreement, then this Agreement

shall not continue on a month-to-month basis but shall be deemed terminated as of the expiration date hereof.

2.4 If, at any time during the term of this Agreement, BellSouth is unable to contact ComSouth pursuant to the Notices provision hereof or any other contact information provided by ComSouth under this Agreement, and there are no active services being provisioned under this Agreement, then BellSouth may, at its discretion, terminate this Agreement, without any liability whatsoever, upon sending of notification to ComSouth pursuant to the Notices section hereof. Furthermore, if after eighteen (18) months following the Effective Date of this Agreement ComSouth has no active services pursuant to this Agreement, BellSouth may terminate this Agreement, without any liability to BellSouth, upon notification to ComSouth pursuant to the Notices section hereof.

2.5 In addition to as otherwise set forth in this Agreement, BellSouth reserves the right to suspend access to ordering systems, refuse to process additional or pending applications for service, or terminate service in the event of prohibited, unlawful or improper use of BellSouth's facilities or service, abuse of BellSouth's facilities or any other material breach of this Agreement, and all monies owed on all outstanding invoices shall become due. In such event, ComSouth is solely responsible for notifying its customers of any discontinuance of service.

3 Nondiscriminatory Access

When ComSouth purchases Telecommunications Services from BellSouth pursuant to Attachment 1 of this Agreement for the purposes of resale to customers, such services shall be equal in quality, subject to the same conditions, and provided within the same provisioning time intervals that BellSouth provides to others, including its customers. To the extent technically feasible, the quality of a Network Element, as well as the quality of the access to such Network Element provided by BellSouth to ComSouth shall be at least equal to that which BellSouth provides to itself and shall be the same for all Telecommunications carriers requesting access to that Network Element. The quality of the interconnection between the network of BellSouth and the network of ComSouth shall be at a level that is equal to that which BellSouth provides itself, a subsidiary, an Affiliate, or any other party. The interconnection facilities shall be designed to meet the same technical criteria and service standards that are used within BellSouth's network and shall extend to a consideration of service quality as perceived by BellSouth's customers and service quality as perceived by ComSouth.

4 Court Ordered Requests for Call Detail Records and Other Subscriber Information

4.1 Subpoenas Directed to BellSouth. Where BellSouth provides resold services for ComSouth, BellSouth shall respond to subpoenas and court ordered requests delivered directly to BellSouth for the purpose of providing call detail records when the targeted telephone numbers belong to ComSouth customers. Billing for such requests will be generated by BellSouth and directed to the law enforcement

agency initiating the request. BellSouth shall maintain such information for ComSouth customers for the same length of time it maintains such information for its own customers.

4.2 Subpoenas Directed to ComSouth. Where BellSouth is providing resold services to ComSouth, , then ComSouth agrees that in those cases where ComSouth receives subpoenas or court ordered requests regarding targeted telephone numbers belonging to ComSouth customers, and where ComSouth does not have the requested information, ComSouth will advise the law enforcement agency initiating the request to redirect the subpoena or court ordered request to BellSouth for handling in accordance with Section 4.1 above.

4.3 In all other instances, where either Party receives a request for information involving the other Party's customer, the Party receiving the request will advise the law enforcement agency initiating the request to redirect such request to the other Party.

5 Liability and Indemnification

5.1 ComSouth Liability. In the event that ComSouth consists of two (2) or more separate entities as set forth in this Agreement and/or any Amendments hereto, or any third party places orders under this Agreement using ComSouth's company codes or identifiers, all such entities shall be jointly and severally liable for the obligations of ComSouth under this Agreement.

5.2 Liability for Acts or Omissions of Third Parties. BellSouth shall not be liable to ComSouth for any act or omission of another entity providing any services to ComSouth.

5.3 Except for any indemnification obligations of the Parties hereunder, each Party's liability to the other for any loss, cost, claim, injury, liability or expense, including reasonable attorneys' fees relating to or arising out of any cause whatsoever, whether based in contract, negligence or other tort, strict liability or otherwise, relating to the performance of this Agreement, shall not exceed a credit for the actual cost of the services or functions not performed or improperly performed. Any amounts paid to ComSouth pursuant to Attachment 9 hereof shall be credited against any damages otherwise payable to ComSouth pursuant to this Agreement.

5.3.1 Limitations in Tariffs. A Party may, in its sole discretion, provide in its tariffs and contracts with its customers and third parties that relate to any service, product or function provided or contemplated under this Agreement, that to the maximum extent permitted by Applicable Law, such Party shall not be liable to the customer or third party for (i) any loss relating to or arising out of this Agreement, whether in contract, tort or otherwise, that exceeds the amount such Party would have charged that applicable person for the service, product or function that gave rise to such loss and (ii) consequential damages. To the extent that a Party elects not to place in its tariffs or contracts such limitations of liability, and the other Party

incurs a loss as a result thereof, such Party shall, except to the extent caused by the other Party's gross negligence or willful misconduct, indemnify and reimburse the other Party for that portion of the loss that would have been limited had the first Party included in its tariffs and contracts the limitations of liability that such other Party included in its own tariffs at the time of such loss.

5.3.2 Neither BellSouth nor ComSouth shall be liable for damages to the other Party's terminal location, equipment or customer premises resulting from the furnishing of a service, including, but not limited to, the installation and removal of equipment or associated wiring, except to the extent caused by a Party's negligence or willful misconduct or by a Party's failure to ground properly a local loop after disconnection.

5.3.3 Under no circumstance shall a Party be responsible or liable for indirect, incidental, or consequential damages, including, but not limited to, economic loss or lost business or profits, damages arising from the use or performance of equipment or software, or the loss of use of software or equipment, or accessories attached thereto, delay, error, or loss of data. In connection with this limitation of liability, each Party recognizes that the other Party may, from time to time, provide advice, make recommendations, or supply other analyses related to the services or facilities described in this Agreement, and, while each Party shall use diligent efforts in this regard, the Parties acknowledge and agree that this limitation of liability shall apply to provision of such advice, recommendations, and analyses.

5.3.4 To the extent any specific provision of this Agreement purports to impose liability, or limitation of liability, on either Party different from or in conflict with the liability or limitation of liability set forth in this Section, then with respect to any facts or circumstances covered by such specific provisions, the liability or limitation of liability contained in such specific provision shall apply.

5.4 Indemnification for Certain Claims. Except as otherwise set forth in this Agreement and except to the extent caused by the indemnified Party's gross negligence or willful misconduct, the Party providing services hereunder, its Affiliates and its parent company, shall be indemnified, defended and held harmless by the Party receiving services hereunder against any claim, loss or damage arising from the receiving Party's use of the services provided under this Agreement pertaining to (1) claims for libel, slander or invasion of privacy arising from the content of the receiving Party's own communications, or (2) any claim, loss or damage claimed by any third party (including, but not limited to, a customer of the Party receiving services) arising from the third party's use or reliance on and arising from the Party receiving services use or reliance on the providing Party's services, actions, duties, or obligations arising out of this Agreement.

5.5 Disclaimer. EXCEPT AS SPECIFICALLY PROVIDED TO THE CONTRARY IN THIS AGREEMENT, NEITHER PARTY MAKES ANY REPRESENTATIONS OR WARRANTIES TO THE OTHER PARTY CONCERNING THE SPECIFIC QUALITY OF ANY SERVICES, OR

FACILITIES PROVIDED UNDER THIS AGREEMENT. THE PARTIES DISCLAIM, WITHOUT LIMITATION, ANY WARRANTY OR GUARANTEE OF MERCHANTABILITY OR FITNESS FOR A PARTICULAR PURPOSE, ARISING FROM COURSE OF PERFORMANCE, COURSE OF DEALING, OR FROM USAGES OF TRADE.

6 Intellectual Property Rights and Indemnification

6.1 No License. Except as expressly set forth in Section 6.2 below, no patent, copyright, trademark or other proprietary right is licensed, granted or otherwise transferred by this Agreement. The Parties are strictly prohibited from any use, including but not limited to, in the selling, marketing, promoting or advertising of telecommunications services, of any name, service mark, logo or trademark (collectively, the “Marks”) of the other Party. The Marks include those Marks owned directly by a Party or its Affiliate(s) and those Marks that a Party has a legal and valid license to use. The Parties acknowledge that they are separate and distinct and that each provides a separate and distinct service and agree that neither Party may, expressly or impliedly, state, advertise or market that it is or offers the same service as the other Party or engage in any other activity that may result in a likelihood of confusion between its own service and the service of the other Party.

6.2 Ownership of Intellectual Property. Any intellectual property that originates from or is developed by a Party shall remain the exclusive property of that Party. Except for a limited, non-assignable, non-exclusive, non-transferable license to use patents or copyrights to the extent necessary for the Parties to use any facilities or equipment (including software) or to receive any service solely as provided under this Agreement, no license in patent, copyright, trademark or trade secret, or other proprietary or intellectual property right, now or hereafter owned, controlled or licensable by a Party, is granted to the other Party. Neither shall it be implied nor arise by estoppel. Any trademark, copyright or other proprietary notices appearing in association with the use of any facilities or equipment (including software) shall remain on the documentation, material, product, service, equipment or software. It is the responsibility of each Party to ensure at no additional cost to the other Party that it has obtained any necessary licenses in relation to intellectual property of third Parties used in its network that may be required to enable the other Party to use any facilities or equipment (including software), to receive any service, or to perform its respective obligations under this Agreement.

6.3 Intellectual Property Remedies

6.3.1 Indemnification. The Party providing a service pursuant to this Agreement will defend the Party receiving such service or data provided as a result of such service against claims of infringement arising solely from the use by the receiving Party of such service in the manner contemplated under this Agreement and will indemnify the receiving Party for any damages awarded based solely on such claims in accordance with Section 5 above.

6.3.2 Claim of Infringement

6.3.2.1 In the event that use of any facilities or equipment (including software), becomes, or in the reasonable judgment of the Party who owns the affected network is likely to become, the subject of a claim, action, suit, or proceeding based on intellectual property infringement, then said Party, promptly and at its sole expense and sole option, but subject to the limitations of liability set forth below, shall:

6.3.2.2 modify or replace the applicable facilities or equipment (including software) while maintaining form and function, or

6.3.2.3 obtain a license sufficient to allow such use to continue.

6.3.2.4 In the event Sections 6.3.2.2 or 6.3.2.3 above are commercially unreasonable, then said Party may terminate, upon reasonable notice, this contract with respect to use of, or services provided through use of, the affected facilities or equipment (including software), but solely to the extent required to avoid the infringement claim.

6.3.3 Exception to Obligations. Neither Party's obligations under this Section shall apply to the extent the infringement is caused by: (i) modification of the facilities or equipment (including software) by the indemnitee; (ii) use by the indemnitee of the facilities or equipment (including software) in combination with equipment or facilities (including software) not provided or authorized by the indemnitor, provided the facilities or equipment (including software) would not be infringing if used alone; (iii) conformance to specifications of the indemnitee which would necessarily result in infringement; or (iv) continued use by the indemnitee of the affected facilities or equipment (including software) after being placed on notice to discontinue use as set forth herein.

6.3.4 Exclusive Remedy. The foregoing shall constitute the Parties' sole and exclusive remedies and obligations with respect to a third party claim of intellectual property infringement arising out of the conduct of business under this Agreement.

6.3.5 Dispute Resolution. Any claim arising under Sections 6.1 and 6.2 above shall be excluded from the dispute resolution procedures set forth in Section 8 below and shall be brought in a court of competent jurisdiction.

7 **Proprietary and Confidential Information**

7.1 Proprietary and Confidential Information. It may be necessary for BellSouth and ComSouth, each as the "Discloser," to provide to the other Party, as "Recipient," certain proprietary and confidential information (including trade secret information) including but not limited to technical, financial, marketing, staffing and business plans and information, strategic information, proposals, request for proposals, specifications, drawings, maps, prices, costs, costing methodologies, procedures, processes, business systems, software programs, techniques, customer account data, call detail records and like information (collectively the

“Information”). All such Information conveyed in writing or other tangible form shall be clearly marked with a confidential or proprietary legend. Information conveyed orally by the Discloser to Recipient shall be designated as proprietary and confidential at the time of such oral conveyance, shall be reduced to writing by the Discloser within forty-five (45) days thereafter, and shall be clearly marked with a confidential or proprietary legend.

- 7.2 Use and Protection of Information. Recipient agrees to protect such Information of the Discloser provided to Recipient from whatever source from distribution, disclosure or dissemination to anyone except employees consultants, contractors and agents of Recipient or its Affiliates with a need to know such Information solely in conjunction with Recipient’s analysis of the Information and for no other purpose except as authorized herein or as otherwise authorized in writing by the Discloser. Recipients may make tangible or electronic copies, notes, summaries or extracts of Information only as necessary for use as authorized herein. All tangible or electronic copies, notes, summaries or extracts must be marked with the same confidential and proprietary notice as appears on the original. Information remains at all times the property of Discloser. Upon Discloser’s request, all or any requested portion of the Information (including, but not limited to, tangible and electronic copies, notes, summaries or extracts of any Information) will be promptly returned to Discloser or destroyed, and Recipient will provide Discloser with written certification stating that such information has been returned or destroyed.
- 7.3 Exceptions
- 7.3.1 Recipient will not have an obligation to protect any portion of the Information which:
- 7.3.2 (a) is made publicly available by the Discloser or lawfully by a nonparty to this Agreement; (b) is lawfully obtained by Recipient from any source other than Discloser; (c) is previously known to Recipient without an obligation to keep it confidential; or (d) is released from the terms of this Agreement by Discloser upon written notice to Recipient.
- 7.4 Recipient agrees to use the Information solely for the purposes of negotiations pursuant to 47 U.S.C. § 251 or in performing its obligations under this Agreement and for no other entity or purpose, except as may be otherwise agreed to in writing by the Parties. Nothing herein shall prohibit Recipient from providing information requested by the FCC or a state regulatory agency with jurisdiction over this matter, or to support a request for arbitration or an allegation of failure to negotiate in good faith.
- 7.5 Recipient agrees not to publish or use the Information for any advertising, sales or marketing promotions, press releases, or publicity matters that refer either directly or indirectly to the Information or to the Discloser or any of its affiliated companies.

7.6 The disclosure of Information neither grants nor implies any license to the Recipient under any trademark, patent, copyright, application or other intellectual property right that is now or may hereafter be owned by the Discloser.

7.7 Survival of Confidentiality Obligations. The Parties' rights and obligations under this Section 7 shall survive and continue in effect until two (2) years after the expiration or termination date of this Agreement with regard to all Information exchanged during the term of this Agreement. Thereafter, the Parties' rights and obligations hereunder survive and continue in effect with respect to any Information that is a trade secret under applicable law.

8 Resolution of Disputes

Except as otherwise stated in this Agreement, if any dispute arises as to the interpretation of any provision of this Agreement or as to the proper implementation of this Agreement, the aggrieved Party, if it elects to pursue resolution of the dispute, shall petition the Commission for a resolution of the dispute. However, each Party reserves any rights it may have to seek judicial review of any ruling made by the Commission concerning this Agreement.

9 Taxes

9.1 Definition. For purposes of this Section, the terms "taxes" and "fees" shall include but not be limited to federal, state or local sales, use, excise, gross receipts or other taxes or tax-like fees of whatever nature and however designated (including tariff surcharges and any fees, charges or other payments, contractual or otherwise, for the use of public streets or rights of way, whether designated as franchise fees or otherwise) imposed, or sought to be imposed, on or with respect to the services furnished hereunder or measured by the charges or payments therefor, excluding any taxes levied on income.

9.2 Taxes and Fees Imposed Directly On Either Providing Party or Purchasing Party

9.2.1 Taxes and fees imposed on the providing Party, which are not permitted or required to be passed on by the providing Party to its customer, shall be borne and paid by the providing Party.

9.2.2 Taxes and fees imposed on the purchasing Party, which are not required to be collected and/or remitted by the providing Party, shall be borne and paid by the purchasing Party.

9.3 Taxes and Fees Imposed on Purchasing Party But Collected And Remitted By Providing Party

9.3.1 Taxes and fees imposed on the purchasing Party shall be borne by the purchasing Party, even if the obligation to collect and/or remit such taxes or fees is placed on the providing Party.

- 9.3.2 To the extent permitted by applicable law, any such taxes and/or fees shall be shown on applicable billing documents between the Parties. Notwithstanding the foregoing, the purchasing Party shall remain liable for any such taxes and fees regardless of whether they are actually billed by the providing Party at the time that the respective service is billed.
- 9.3.3 If the purchasing Party determines that in its opinion any such taxes or fees are not applicable, the providing Party shall not bill such taxes or fees to the purchasing Party if the purchasing Party provides written certification, reasonably satisfactory to the providing Party, stating that it is exempt or otherwise not subject to the tax or fee, setting forth the basis therefor, and satisfying any other requirements under applicable law. If any authority seeks to collect any such tax or fee that the purchasing Party has determined and certified not to be applicable, or any such tax or fee that was not billed by the providing Party, the purchasing Party may contest the same in good faith, at its own expense. In any such contest, the purchasing Party shall promptly furnish the providing Party with copies of all filings in any proceeding, protest, or legal challenge, all rulings issued in connection therewith, and all correspondence between the purchasing Party and the taxing authority.
- 9.3.4 In the event that all or any portion of an amount sought to be collected must be paid in order to contest the imposition of any such tax or fee, or to avoid the existence of a lien on the assets of the providing Party during the pendency of such contest, the purchasing Party shall be responsible for such payment and shall be entitled to the benefit of any refund or recovery. The purchasing Party shall have the right to contest, at its own expense, any such tax or fee that it believes is not applicable or was paid by it in error. If requested in writing by the purchasing Party, the providing Party shall facilitate such contest either by assigning to the purchasing Party its right to claim a refund of such tax or fee, if such an assignment is permitted under applicable law, or, if an assignment is not permitted, by filing and pursuing a claim for refund on behalf of the purchasing Party but at the purchasing Party's expense.
- 9.3.5 If it is ultimately determined that any additional amount of such a tax or fee is due to the imposing authority, the purchasing Party shall pay such additional amount, including any interest and penalties thereon.
- 9.3.6 Notwithstanding any provision to the contrary, the purchasing Party shall protect, indemnify and hold harmless (and defend at the purchasing Party's expense) the providing Party from and against any such tax or fee, interest or penalties thereon, or other charges or payable expenses (including reasonable attorney fees) with respect thereto, which are incurred by the providing Party in connection with any claim for or contest of any such tax or fee.
- 9.3.7 Each Party shall notify the other Party in writing of any assessment, proposed assessment or other claim for any additional amount of such a tax or fee by a taxing authority; provided, however, that the failure of a Party to provide notice shall not relieve the other Party of any obligations hereunder.

- 9.4 Taxes and Fees Imposed on Providing Party But Passed On To Purchasing Party
- 9.4.1 Taxes and fees imposed on the providing Party, which are permitted or required to be passed on by the providing Party to its customer, shall be borne by the purchasing Party.
- 9.4.2 To the extent permitted by applicable law, any such taxes and/or fees shall be shown on applicable billing documents between the Parties. Notwithstanding the foregoing, the purchasing Party shall remain liable for any such taxes and fees regardless of whether they are actually billed by the providing Party at the time that the respective service is billed.
- 9.4.3 If the purchasing Party disagrees with the providing Party's determination as to the application of or basis for any such tax or fee, the Parties shall consult with respect to the imposition and billing of such tax or fee. Notwithstanding the foregoing, the providing Party shall retain ultimate responsibility for determining whether and to what extent any such taxes or fees are applicable, and the purchasing Party shall abide by such determination and pay such taxes or fees to the providing Party. The providing Party shall further retain ultimate responsibility for determining whether and how to contest the imposition of such taxes and fees; provided, however, that any such contest undertaken at the request of the purchasing Party shall be at the purchasing Party's expense.
- 9.4.4 In the event that all or any portion of an amount sought to be collected must be paid in order to contest the imposition of any such tax or fee, or to avoid the existence of a lien on the assets of the providing Party during the pendency of such contest, the purchasing Party shall be responsible for such payment and shall be entitled to the benefit of any refund or recovery. The purchasing Party shall have the right to contest, at its own expense, any such tax or fee that it believes is not applicable or was paid by it in error. If requested in writing by the purchasing Party, the providing Party shall facilitate such contest either by assigning to the purchasing Party its right to claim a refund of such tax or fee, if such an assignment is permitted under applicable law, or, if an assignment is not permitted, by filing and pursuing a claim for refund on behalf of the purchasing Party but at the purchasing Party's expense.
- 9.4.5 If it is ultimately determined that any additional amount of such a tax or fee is due to the imposing authority, the purchasing Party shall pay such additional amount, including any interest and penalties thereon.
- 9.4.6 Notwithstanding any provision to the contrary, the purchasing Party shall protect, indemnify and hold harmless (and defend at the purchasing Party's expense) the providing Party from and against any such tax or fee, interest or penalties thereon, or other charges or payable expenses (including reasonable attorneys' fees) with respect thereto, which are incurred by the providing Party in connection with any claim for or contest of any such tax or fee.

9.4.7 Each Party shall notify the other Party in writing of any assessment, proposed assessment or other claim for any additional amount of such a tax or fee by a taxing authority; provided, however, that the failure of a Party to provide notice shall not relieve the other Party of any obligations hereunder.

9.5 Additional Provisions Applicable to All Taxes and Fees

9.5.1 In any contest of a tax or fee by one Party, the other Party shall cooperate fully by providing records, testimony and such additional information or assistance as may reasonably be necessary to pursue the contest. Further, the other Party shall be reimbursed for any reasonable and necessary out-of-pocket copying and travel expenses incurred in assisting in such contest.

9.5.2 Notwithstanding any provision of this Agreement to the contrary, any administrative, judicial, or other proceeding concerning the application or amount of a tax or fee shall be maintained in accordance with the provisions of this Section and any applicable federal, state or local law governing the resolution of such disputed tax or fee; and under no circumstances shall either Party have the right to bring a dispute related to the application or amount of a tax or fee before a regulatory authority.

10 Force Majeure

In the event performance of this Agreement, or any obligation hereunder, is either directly or indirectly prevented, restricted, or interfered with by reason of fire, flood, earthquake or like acts of God, wars, revolution, civil commotion, explosion, acts of public enemy, embargo, acts of the government in its sovereign capacity, labor difficulties, including without limitation, strikes, slowdowns, picketing, or boycotts, unavailability of equipment from vendor, changes requested by ComSouth, or any other circumstances beyond the reasonable control and without the fault or negligence of the Party affected, the Party affected shall be excused from such performance on a day-to-day basis to the extent of such prevention, restriction, or interference (and the other Party shall likewise be excused from performance of its obligations on a day-to-day basis until the delay, restriction or interference has ceased); provided, however, that the Party so affected shall use diligent efforts to avoid or remove such causes of non-performance and both Parties shall proceed whenever such causes are removed or cease. The Party affected shall provide notice of the Force Majeure event within a reasonable period of time following such an event.

11 Adoption of Agreements

Pursuant to 47 U.S.C. § 252(i) and 47 C.F.R. § 51.809, BellSouth shall make available to ComSouth any entire interconnection agreement filed and approved pursuant to 47 U.S.C. § 252. The adopted agreement shall apply to the same states as the agreement that was adopted, and the term of the adopted agreement shall expire on the same date as set forth in the agreement that was adopted.

12 Modification of Agreement

- 12.1 If ComSouth changes its name or makes changes to its company structure or identity due to a merger, acquisition, transfer or any other reason, it is the responsibility of ComSouth to notify BellSouth of said change, request that an amendment to this Agreement, if necessary, be executed to reflect said change and notify the Commission of such modification of company structure in accordance with the state rules governing such modification in company structure if applicable. Additionally, ComSouth shall provide BellSouth with any necessary supporting documentation, which may include, but is not limited to, a credit application, Application for Master Account, proof of authority to provide telecommunications services, the appropriate Operating Company Number (OCN) for each state as assigned by National Exchange Carrier Association (NECA), Carrier Identification Code (CIC), Access Customer Name and Abbreviation (ACNA), BellSouth's blanket form letter of authority (LOA), Misdirected Number form and a tax exemption certificate.
- 12.2 No modification, amendment, supplement to, or waiver of the Agreement or any of its provisions shall be effective and binding upon the Parties unless it is made in writing and duly signed by the Parties.
- 12.3 In the event that any effective legislative, regulatory, judicial or other legal action materially affects any material terms of this Agreement, or the ability of ComSouth or BellSouth to perform any material terms of this Agreement, ComSouth or BellSouth may, on thirty (30) days' written notice, require that such terms be renegotiated, and the Parties shall renegotiate in good faith such mutually acceptable new terms as may be required. In the event that such new terms are not renegotiated within forty-five (45) days after such notice, and either Party elects to pursue resolution of such amendment such Party shall pursue the dispute resolution process set forth in Section 8 above.

13 Legal Rights

Execution of this Agreement by either Party does not confirm or imply that the executing Party agrees with any decision(s) issued pursuant to the Telecommunications Act of 1996 and the consequences of those decisions on specific language in this Agreement. Neither Party waives its rights to appeal or otherwise challenge any such decision(s) and each Party reserves all of its rights to pursue any and all legal and/or equitable remedies, including appeals of any such decision(s).

14 Indivisibility

Subject to Section 15 below, the Parties intend that this Agreement be indivisible and nonseverable, and each of the Parties acknowledges that it has assented to all of the covenants and promises in this Agreement as a single whole and that all of such covenants and promises, taken as a whole, constitute the essence of the contract. Without limiting the generality of the foregoing, each of the Parties acknowledges that any provision by BellSouth of collocation space under this

Agreement is solely for the purpose of facilitating the provision of other services under this Agreement as set forth in Attachment 4. The Parties further acknowledge that this Agreement is intended to constitute a single transaction and that the obligations of the Parties under this Agreement are interdependent.

15 Severability

If any provision of this Agreement, or part thereof, shall be held invalid or unenforceable in any respect, the remainder of the Agreement or provision shall not be affected thereby, provided that the Parties shall negotiate in good faith to reformulate such invalid provision, or part thereof, or related provision, to reflect as closely as possible the original intent of the parties, consistent with applicable law, and to effectuate such portions thereof as may be valid without defeating the intent of such provision. In the event the Parties are unable to mutually negotiate such replacement language, either Party may elect to pursue the dispute resolution process set forth in Section 8 above.

16 Non-Waivers

A failure or delay of either Party to enforce any of the provisions hereof, to exercise any option which is herein provided, or to require performance of any of the provisions hereof shall in no way be construed to be a waiver of such provisions or options, and each Party, notwithstanding such failure, shall have the right thereafter to insist upon the performance of any and all of the provisions of this Agreement.

17 Governing Law

Where applicable, this Agreement shall be governed by and construed in accordance with federal and state substantive telecommunications law, including rules and regulations of the FCC and appropriate Commission. In all other respects, this Agreement shall be governed by and construed and enforced in accordance with the laws of the State of Georgia without regard to its conflict of laws principles.

18 Assignments and Transfers

- 18.1 Any assignment by either Party to any entity of any right, obligation or duty, or of any other interest hereunder, in whole or in part, without the prior written consent of the other Party shall be void. The assignee must provide evidence of a Commission approved certification to provide Telecommunications Service in each state that ComSouth is entitled to provide Telecommunications Service. After BellSouth's consent, the Parties shall amend this Agreement to reflect such assignments and shall work cooperatively to implement any changes required due to such assignment. All obligations and duties of any Party under this Agreement shall be binding on all successors in interest and assigns of such Party. No assignment or delegation hereof shall relieve the assignor of its obligations under this Agreement in the event that the assignee fails to perform such obligations. Notwithstanding anything to the contrary in this Section, ComSouth shall not be permitted to assign this Agreement in whole or in part to any entity unless either

(1) ComSouth pays all bills, past due and current, under this Agreement, or (2) ComSouth's assignee expressly assumes liability for payment of such bills.

18.2 In the event that ComSouth desires to transfer any services hereunder to another provider of Telecommunications Service, or ComSouth desires to assume hereunder any services provisioned by BellSouth to another provider of Telecommunications Service, such transfer of services shall be subject to separately negotiated rates, terms and conditions.

19 Notices

19.1 Every notice, consent or approval of a legal nature, required or permitted by this Agreement shall be in writing and shall be delivered either by hand, by overnight courier or by US mail postage prepaid, or email if an email address is listed below, addressed to:

BellSouth Telecommunications, Inc.

BellSouth Local Contract Manager
600 North 19th Street, 10th floor
Birmingham, AL 35203

and

Business Markets Attorney
Suite 4300
675 West Peachtree Street
Atlanta, GA 30375

ComSouth Telenet, Inc.

Mike McClain - CFO
ComSouth Telenet, Inc.
P.O. Box 1298
Hawkinsville, GA 31036
mikemcclain@comsouth.net
478.783.4001

or at such other address as the intended recipient previously shall have designated by written notice to the other Party.

19.2 Unless otherwise provided in this Agreement, notice by mail shall be effective on the date it is officially recorded as delivered by return receipt or equivalent, and in the absence of such record of delivery, it shall be presumed to have been delivered the fifth day, or next business day after the fifth day, after it was deposited in the mails.

19.3 Notwithstanding the above, BellSouth will post to BellSouth's Interconnection Web site changes to business processes and policies and shall post to BellSouth's Interconnection Web site or submit through applicable electronic systems, other service and business related notices not requiring an amendment to this Agreement.

20 Rule of Construction

No rule of construction requiring interpretation against the drafting Party hereof shall apply in the interpretation of this Agreement.

21 Headings of No Force or Effect

The headings of Articles and Sections of this Agreement are for convenience of reference only, and shall in no way define, modify or restrict the meaning or interpretation of the terms or provisions of this Agreement.

22 Multiple Counterparts

This Agreement may be executed in multiple counterparts, each of which shall be deemed an original, but all of which shall together constitute but one and the same document.

23 Filing of Agreement

This Agreement, and any amendments hereto, shall be filed with the appropriate state regulatory agency pursuant to the requirements of Section 252 of the Act, or as otherwise required by the state and the Parties shall share equally in any applicable fees. Notwithstanding the foregoing, this Agreement shall not be submitted for approval by the appropriate state regulatory agency unless and until such time as ComSouth is duly certified as a local exchange carrier in such state, except as otherwise required by a Commission.

24 Compliance with Law

The Parties have negotiated their respective rights and obligations pursuant to substantive Federal and State Telecommunications law and this Agreement is intended to memorialize the Parties' mutual agreement with respect to each Party's rights and obligations under the Act and applicable FCC and Commission orders, rules and regulations. Nothing contained herein, nor any reference to applicable rules and orders, is intended to expand on the Parties' rights and obligations as set forth herein. This Agreement also contains certain provisions that were negotiated without regard to the Parties' obligations as set forth Section 251 of the Act. To the extent the provisions of this Agreement differ from the provisions of any Federal or State Telecommunications statute, rule or order in effect as of the execution of this Agreement, this Agreement shall control. Each Party shall comply at its own expense with all other laws of general applicability.

25 Necessary Approvals

Each Party shall be responsible for obtaining and keeping in effect all approvals from, and rights granted by, governmental authorities, building and property owners, other carriers, and any other persons that may be required in connection

with the performance of its obligations under this Agreement. Each Party shall reasonably cooperate with the other Party in obtaining and maintaining any required approvals and rights for which such Party is responsible.

26 Good Faith Performance

Each Party shall act in good faith in its performance under this Agreement and, in each case in which a Party's consent or agreement is required or requested hereunder, such Party shall not unreasonably withhold or delay such consent or agreement.

27 Rates

27.1 ComSouth shall pay the charges set forth in this Agreement. In the event that BellSouth is unable to bill the applicable rate, an established rate has been misapplied or no rate is established or included in this Agreement for any services provided pursuant to this Agreement, BellSouth reserves the right to back bill ComSouth for such rate or for the difference between the rate actually billed and the rate that should have been billed pursuant to this Agreement; provided, however, that subject to ComSouth's agreement to the limitation regarding billing disputes as described in Section 2.2 of Attachment 7 hereof, BellSouth shall not back bill any amounts for services rendered more than twelve (12) months prior to the date that the charges or additional charges for such services are actually billed. Notwithstanding the foregoing, both Parties recognize that situations may exist which could necessitate back billing beyond twelve (12) months. These exceptions are:

- Charges connected with jointly provided services whereby meet point billing guidelines require either Party to rely on records provided by a third party and such records have not been provided in a timely manner;
- Charges incorrectly billed due to erroneous information supplied by the non-billing Party;
- Charges for which a regulatory body has granted, or a regulatory change permits, the billing Party the authority to back bill.

27.2 To the extent a rate element is omitted or no rate is established, BellSouth has the right not to provision such service until the Agreement is amended to include such rate.

27.3 To the extent ComSouth requests services not included in this Agreement, such services shall be provisioned pursuant to the rates, terms and conditions set forth in the applicable tariffs or a separately negotiated Agreement, unless the Parties agree to amend this Agreement to include such service prospectively.

28 Rate True-Up

- 28.1 This section applies to rates that are expressly subject to true-up.
- 28.2 The rates shall be trued-up, either up or down, based on final prices determined either by further agreement between the Parties, or by a final and effective order of the Commission. The Parties shall implement the true-up by comparing the actual volumes and demand for each item, together with the rates for each item, with the final prices determined for each item. Each Party shall keep its own records upon which the true-up can be based, and any final payment from one Party to the other shall be in an amount agreed upon by the Parties based on such records. In the event of any discrepancy between the records or disagreement between the Parties regarding the amount of such true-up, the dispute shall be subject to the dispute resolution process set forth in this Agreement.
- 28.3 A final and effective order of the Commission that forms the basis of a true-up shall be based upon cost studies submitted by either or both Parties to the Commission and shall be binding upon BellSouth and ComSouth specifically or upon all carriers generally, such as a generic cost proceeding.

29 Survival

The Parties' obligations under this Agreement which by their nature are intended to continue beyond the termination or expiration of this Agreement shall survive the termination or expiration of this Agreement.

30 Entire Agreement

- 30.1 This Agreement means the General Terms and Conditions, the Attachments hereto and all documents identified therein, as such may be amended from time to time and which are incorporated herein by reference, all of which, when taken together, are intended to constitute one indivisible agreement. This Agreement sets forth the entire understanding and supersedes prior agreements between the Parties relating to the subject matter contained in this Agreement and merges all prior discussions between them. Any orders placed under prior agreements between the Parties shall be governed by the terms of this Agreement and ComSouth acknowledges and agrees that any and all amounts and obligations owed for services provisioned or orders placed under prior agreements between the Parties, related to the subject matter hereof, shall, as of the Effective Date, be due and owing under this Agreement and be governed by the terms and conditions of this Agreement as if such services or orders were provisioned or placed under this Agreement. Neither Party shall be bound by any definition, condition, provision, representation, warranty, covenant or promise other than as expressly stated in this Agreement or as is contemporaneously or subsequently set forth in writing and executed by a duly authorized officer or representative of the Party to be bound thereby.
- 30.2 Any reference throughout this Agreement to a tariff, industry guideline, BellSouth's technical guideline or reference, BellSouth business rule, guide or

other such document containing processes or specifications applicable to the services provided pursuant to this Agreement, shall be construed to refer to only those provisions thereof that are applicable to these services, and shall include any successor or replacement versions thereof, all as they are amended from time to time and all of which are incorporated herein by reference, and may be found at BellSouth's Interconnection Web site at: www.interconnection.bellsouth.com. References to state tariffs throughout this Agreement shall be to the tariff for the state in which the services were provisioned; provided, however, that in any state where certain BellSouth services or tariff provisions have been or become deregulated or detariffed, any reference in this Agreement to a detariffed or deregulated service or provision of such tariff shall be deemed to refer to the service description, price list or other agreement pursuant to which BellSouth provides such services as a result of detariffing or deregulation.

General Terms and Conditions
Signature Page

IN WITNESS WHEREOF, the Parties have executed this Agreement the day and year written below.

BellSouth Telecommunications, Inc.

ComSouth Telenet, Inc.

By: *Kristen E. Shore*

By: *Mike McClain*

Name: Kristen E. Shore

Name: Mike McClain

Title: Director

Title: EVP + COO

Date: 1/2/2007

Date: 12/27/06

Attachment 1

Resale

Table of Contents

1. Discount Rates.....3

2. Definition of Terms3

3. General Provisions3

4 BellSouth’s Provision of Services to ComSouth.....6

5. Maintenance of Services.....7

6. Discontinuance of Service7

7. White Pages Listings7

8. Operator Services (Operator Call Processing and Directory Assistance).....9

9. Branding for Wholesale OCP and DA 10

10. LIDB 11

11. Revenue Accounting Office (RAO) Hosting..... 12

12. Optional Daily Usage File (ODUF)..... 12

13. Enhanced Optional Daily Usage File (EODUF) 12

Resale RestrictionsExhibit A

Optional Daily Usage File (ODUF)..... Exhibit B

Enhanced Option Daily Usage File (EODUF).....Exhibit C

Resale Discounts and RatesExhibit D

RESALE

1. Discount Rates

- 1.1 The discounts rates applied to ComSouth's purchases of BellSouth Telecommunications Services for the purpose of resale shall be as set forth in Exhibit D. Such discounts have been determined by the applicable Commission to reflect the costs avoided by BellSouth when selling a service for wholesale purposes.
- 1.2 The Telecommunications Services available for purchase by ComSouth for the purposes of resale to ComSouth's customers shall be available at BellSouth's tariffed rates less the discount reflected in Exhibit D and subject to the exclusions and limitations in Exhibit A.

2. Definition of Terms

For purposes of this Attachment only, the following terms shall have the definitions as set forth below:

- 2.1 Customer of Record means the entity responsible for placing application for service; requesting additions, rearrangements, maintenance or discontinuance of service; payment in full of charges incurred such as nonrecurring, monthly recurring, toll, directory assistance, etc.
- 2.2 End User Customer Location means the physical location of the premises where a customer makes use of the Telecommunications Services.
- 2.3 New Services means functions, features or capabilities that are not currently offered by BellSouth. This includes packaging of existing services or combining a new function, feature or capability with an existing service.
- 2.4 Resale means an activity wherein a certificated CLEC, such as ComSouth, subscribes to the retail Telecommunications Services of BellSouth and then offers those retail Telecommunications Services to the public.

3. General Provisions

- 3.1 All of the negotiated rates, terms and conditions set forth in this Attachment pertain to the resale of BellSouth's retail Telecommunications Services and other services specified in this Attachment. Subject to effective and applicable FCC and Commission rules and orders, BellSouth shall make available to ComSouth for resale those Telecommunications Services BellSouth makes available, pursuant to its General Subscriber Services Tariff (GSST) and Private Line Services Tariff, to customers who are not Telecommunications carriers.
 - 3.1.1 When ComSouth provides Resale service in a cross boundary area (customer is physically located in a particular state and is served by a central office in an adjoining state) the rates, regulations and discounts for the state in which the serving central office is located will apply. Billing will be from the state in which the customer is located.

- 3.2 ComSouth as a reseller of Lifeline and Link-Up Services hereby certifies that it has and will comply with the FCC requirements governing the Lifeline and Link-Up programs as set forth in 47 C.F.R. § 54.417(a) and (b). This includes the requirements set forth in BellSouth's GSST, Sections A3.31 and A4.7.
- 3.2.1 ComSouth shall maintain records to document FCC or applicable state eligibility and verification records to document compliance governing the Lifeline/Link-Up programs for the three (3) full preceding calendar years, and ComSouth shall provide such documentation to the FCC or its Administrator upon request.
- 3.3 ComSouth may purchase resale services from BellSouth for its own use in operating its business. The resale discount will apply to those services under the following conditions:
- 3.3.1 ComSouth must resell services to other end users.
- 3.3.2 ComSouth cannot be a CLEC for the single purpose of selling to itself.
- 3.3.3 ComSouth will be the Customer of Record for all services purchased from BellSouth. Except as specified herein, BellSouth will take orders from, bill and receive payment from ComSouth for said services.
- 3.4 ComSouth will be BellSouth's single point of contact for all services purchased pursuant to this Agreement. BellSouth shall have no contact with the customer except to the extent provided for herein.
- 3.5 BellSouth will continue to bill the customer for any services that the customer specifies it wishes to receive directly from BellSouth. BellSouth maintains the right to serve directly any customer within the service area of ComSouth. BellSouth will continue to market directly its own Telecommunications products and services and in doing so may establish independent relationships with customers of ComSouth. Neither Party shall interfere with the right of any person or entity to obtain service directly from the other Party.
- 3.5.1 BellSouth will accept a request from another CLEC for conversion of the customer's service from ComSouth to such other CLEC. Upon completion of the conversion BellSouth will notify ComSouth that such conversion has been completed.
- 3.5.2 When a customer of ComSouth or BellSouth elects to change his/her carrier to the other Party, both Parties agree to release the customer's service to the other Party concurrent with the due date of the service order, which shall be established based on the standard interval for the customer's requested service as set forth in the BellSouth Product and Services Interval Guide.
- 3.5.3 BellSouth and ComSouth will refrain from contacting a customer who has placed or whose selected carrier has placed on the customer's behalf an order to change the customer's service provider from BellSouth or ComSouth to the other Party until such time that the order for service has been completed.
- 3.6 Current telephone numbers may normally be retained by the customer and are assigned to the service furnished. However, neither Party nor the customer has a property right to the telephone number or any other call number designation

associated with services furnished by BellSouth, and no right to the continuance of service through any particular central office. BellSouth reserves the right to change such numbers, or the central office designation associated with such numbers, or both, whenever BellSouth deems it necessary to do so in the conduct of its business and in accordance with BellSouth practices and procedures on a nondiscriminatory basis.

- 3.7 Service is furnished subject to the condition that it will not be used for any unlawful purpose.
- 3.8 Service will be discontinued if any law enforcement agency advises that the service being used is in violation of the law.
- 3.9 BellSouth can refuse service when it has grounds to believe that service will be used in violation of the law.
- 3.10 If ComSouth or its customers utilize a BellSouth resold Telecommunications Service in a manner other than that for which the service was originally intended as described in BellSouth's retail tariffs ComSouth has the responsibility to notify BellSouth. BellSouth will only provision and maintain said service consistent with the terms and conditions of the tariff describing said service.
- 3.11 Facilities and/or equipment utilized by BellSouth to provide service to ComSouth remain the property of BellSouth.
- 3.12 Service Ordering and Operations Support Systems (OSS)
- 3.12.1 ComSouth must order services through resale interfaces, i.e., the Local Carrier Service Center (LCSC) and/or appropriate Complex Resale Support Group (CRSG) pursuant to this Agreement. ComSouth may submit a Local Service Request (LSR) electronically as set forth in Attachment 6. Service orders will be in a standard format designated by BellSouth.
- 3.12.2 BellSouth messaging services set forth in BellSouth's Messaging Service Re-Seller Information Package shall be made available for resale without the wholesale discount.
- 3.13 BellSouth's Inside Wire Maintenance Service Plan is available for resale at rates, terms and conditions as set forth by BellSouth and without the wholesale discount.
- 3.14 In the event ComSouth acquires a customer whose service is provided pursuant to a BellSouth Special Assembly, BellSouth shall make available to ComSouth that Special Assembly at the wholesale discount at ComSouth's option. ComSouth shall be responsible for all terms and conditions of such Special Assembly including but not limited to termination liability if applicable.
- 3.15 BellSouth shall provide 911/E911 for ComSouth customers in the same manner that it is provided to BellSouth customers. BellSouth shall provide and validate ComSouth customer information to the Public Safety Answering Point (PSAP). BellSouth shall use its service order process to update and maintain, on the same schedule that it uses for its customers, the ComSouth customer information in the Automatic Location Identification/Data Management System (ALI/DMS)

databases used to support 911/E911 services.

- 3.16 Pursuant to 47 C.F.R. § 51.617, BellSouth shall bill to ComSouth, and ComSouth shall pay, the End User Common Line (EUCL) charges identical to the EUCL charges BellSouth bills its customers.

4 BellSouth's Provision of Services to ComSouth

- 4.1 Resale of BellSouth services shall be as follows:

4.1.1 The resale of Telecommunications Services shall be limited to users and uses conforming to the class of service restrictions.

4.1.2 Hotel and Hospital PBX services are the only Telecommunications Services available for resale to Hotel/Motel and Hospital customers, respectively. Similarly, Access Line Service for Customer Provided Coin Telephones is the only local service available for resale to Payphone Service Provider (PSP) customers. Shared Tenant Service customers can only be sold those local exchange access services available in BellSouth's GSST Section A23, Shared Tenant Service Section in the state of Georgia.

4.1.3 BellSouth reserves the right to periodically audit services purchased by ComSouth to establish authenticity of use. Such audit shall not occur more than once in a calendar year. ComSouth shall make any and all records and data available to BellSouth or BellSouth's auditors on a reasonable basis. BellSouth shall bear the cost of said audit. Any information provided by ComSouth for purposes of such audit shall be deemed Confidential Information pursuant to the General Terms and Conditions.

4.2 Subject to Exhibit A hereto, resold services can only be used in the same manner as specified in BellSouth's Tariffs. Resold services are subject to the same terms and conditions as are specified for such services when furnished to an individual customer of BellSouth in the appropriate section of BellSouth's Tariffs. Specific tariff features (e.g., a usage allowance per month) shall not be aggregated across multiple resold services.

4.3 If ComSouth cancels an order for resold services, any costs incurred by BellSouth in conjunction with provisioning of such order will be recovered in accordance with BellSouth's GSST and Private Line Services Tariffs.

4.4 Service Jointly Provisioned with an Independent Company or CLEC

4.4.1 BellSouth will in some instances provision resold services in accordance with BellSouth's GSST and Private Line Tariffs jointly with an Independent Company (ICO) or other CLEC.

4.4.2 When ComSouth assumes responsibility for such service, all terms and conditions defined in the Tariff will apply for services provided within the BellSouth service area only.

4.4.3 Service terminating in an ICO or other CLEC area will be provisioned and billed by the ICO or other CLEC directly to ComSouth.

4.4.4 ComSouth must establish a billing arrangement with the ICO or other CLEC prior

to assuming a customer account where such circumstances apply.

- 4.4.5 Specific guidelines regarding such services are available on the BellSouth Interconnection Web site.

5. Maintenance of Services

- 5.1 Services resold pursuant to this Attachment and BellSouth's GSST and Private Line Service Tariff and facilities and equipment provided by BellSouth shall be maintained by BellSouth.
- 5.2 ComSouth or its customers may not rearrange, move, disconnect, remove or attempt to repair any facilities owned by BellSouth except with the written consent of BellSouth.
- 5.3 ComSouth accepts responsibility to notify BellSouth of situations that arise that may result in a service problem.
- 5.4 ComSouth will contact the appropriate repair centers in accordance with procedures established by BellSouth.
- 5.5 For all repair requests, ComSouth shall adhere to BellSouth's prescreening guidelines prior to referring the trouble to BellSouth.
- 5.6 BellSouth reserves the right to contact ComSouth's customers, if deemed necessary, for maintenance purposes.

6. Discontinuance of Service

- 6.1 The procedures for discontinuing service to a customer are as follows:
- 6.1.1 BellSouth will deny service to ComSouth's customer on behalf of, and at the request of, ComSouth. Upon restoration of the customer's service, restoral charges will apply and will be the responsibility of ComSouth.
- 6.1.2 At the request of ComSouth, BellSouth will disconnect a ComSouth customer.
- 6.1.3 All requests by ComSouth for denial or disconnection of a customer for nonpayment must be in writing.
- 6.1.4 ComSouth will be made solely responsible for notifying the customer of the proposed disconnection of the service.
- 6.1.5 BellSouth will continue to process calls made to the Annoyance Call Center and will advise ComSouth when it is determined that annoyance calls are originated from one of its customer's locations. BellSouth shall be indemnified, defended and held harmless by ComSouth and/or the customer against any claim, loss or damage arising from providing this information to ComSouth. It is the responsibility of ComSouth to take the corrective action necessary with its customer who make annoying calls. (Failure to do so will result in BellSouth's disconnecting the customer's service.)

7. White Pages Listings

- 7.1 BellSouth shall provide ComSouth and its end users access to white pages directory listings under the following terms:

- 7.1.1 Listings. ComSouth shall provide all new, changed and deleted listings on a timely basis and BellSouth or its agent will include ComSouth residential and business customer listings in the appropriate White Pages (residential and business) or alphabetical directories in the geographic areas covered by this Agreement. Directory listings will make no distinction between ComSouth and BellSouth customers. ComSouth shall provide listing information in accordance with the procedures set forth in The BellSouth Business Rules for Local Ordering found at BellSouth's Interconnection Services Web site.
- 7.1.2 Unlisted/Non-Published Customers. ComSouth will be required to provide to BellSouth the names, addresses and telephone numbers of all ComSouth customers who wish to be omitted from directories. Unlisted/Non-Published listings will be subject to the rates as set forth in BellSouth's GSST and shall not be subject to the wholesale discount.
- 7.1.3 Inclusion of ComSouth Customers in Directory Assistance Database. BellSouth will include and maintain ComSouth customer listings in BellSouth's Directory Assistance databases. ComSouth shall provide such Directory Assistance listings to BellSouth at no charge.
- 7.1.4 Listing Information Confidentiality. BellSouth will afford ComSouth's directory listing information the same level of confidentiality that BellSouth affords its own directory listing information.
- 7.1.5 Additional and Designer Listings. Additional and designer listings will be offered by BellSouth at tariffed rates as set forth in BellSouth's GSST and shall not be subject to the wholesale discount.
- 7.1.6 Rates. So long as ComSouth provides listing information to BellSouth as set forth in Section 7.1.2 above, BellSouth shall provide to ComSouth one (1) basic White Pages directory listing per ComSouth customer at no charge other than the manual service order charge or the electronic service order charge, as appropriate, as described in Attachment 6.
- 7.2 Directories. BellSouth or its agent shall make available White Pages directories to ComSouth customer at no charge or as specified in a separate agreement between ComSouth and BellSouth's agent.
- 7.3 Procedures for submitting ComSouth Subscriber Listing Information (SLI) are found in The BellSouth Business Rules for Local Ordering found at BellSouth's Interconnection Services Web site.
- 7.3.1 ComSouth authorizes BellSouth to release all ComSouth SLI provided to BellSouth by ComSouth to qualifying third parties pursuant to either a license agreement or BellSouth's Directory Publishers Database Service (DPDS) in BellSouth's GSST. Such ComSouth SLI shall be intermingled with BellSouth's own customer listings and listings of any other CLEC that has authorized a similar release of SLI.
- 7.3.2 No compensation shall be paid to ComSouth for BellSouth's receipt of ComSouth's SLI, or for the subsequent release to third parties of such SLI. In addition, to the extent BellSouth incurs costs to modify its systems to enable the

release of ComSouth's SLI, or costs on an ongoing basis to administer the release of ComSouth's SLI, ComSouth shall pay to BellSouth its proportionate share of the reasonable costs associated therewith. At any time that costs may be incurred to administer the release of ComSouth's SLI, ComSouth will be notified. If ComSouth does not wish to pay its proportionate share of these reasonable costs, ComSouth may instruct BellSouth that it does not wish to release its SLI to independent publishers, and ComSouth shall amend this Agreement accordingly. ComSouth will be liable for all costs incurred until the effective date of the amendment.

7.3.3 Neither BellSouth nor any agent shall be liable for the content or accuracy of any SLI provided by ComSouth under this Agreement. ComSouth shall indemnify, except to the extent caused by BellSouth's gross negligence or willful misconduct, hold harmless and defend BellSouth and its agents from and against any damages, losses, liabilities, demands, claims, suits, judgments, costs and expenses (including but not limited to reasonable attorneys' fees and expenses) arising from BellSouth's Tariff obligations or otherwise and resulting from or arising out of any third party's claim of inaccurate ComSouth listings or use of the SLI provided pursuant to this Agreement. BellSouth may forward to ComSouth any complaints received by BellSouth relating to the accuracy or quality of ComSouth listings.

7.3.4 Listings and subsequent updates will be released consistent with BellSouth system changes and/or update scheduling requirements.

8. Operator Services (Operator Call Processing and Directory Assistance)

8.1 Operator Call Processing (OCP) provides: (1) operator handling for call completion (for example, collect, third number billing, and manual calling-card calls); (2) operator or automated assistance for billing after the customer has dialed the called number (for example, calling card calls); and (3) special services including but not limited to Busy Line Verification and Emergency Line Interrupt (ELI), Emergency Agency Call and operator-assisted Directory Assistance (DA).

8.2 Upon request for BellSouth OCP, BellSouth shall:

8.2.1 Process 0+ and 0- dialed local calls.

8.2.2 Process 0+ and 0- intraLATA toll calls.

8.2.3 Process calls that are billed to ComSouth customer's calling card that can be validated by BellSouth.

8.2.4 Process person-to-person calls.

8.2.5 Process collect calls.

8.2.6 Provide the capability for callers to bill a third party and shall also process such calls.

8.2.7 Process station-to-station calls.

8.2.8 Process Busy Line Verify and ELI requests.

- 8.2.9 Process emergency call trace originated by PSAP.
- 8.2.10 Process operator-assisted DA calls.
- 8.2.11 Adhere to equal access requirements, providing ComSouth local customer the same IXC access that BellSouth provides its own operator service (OS).
- 8.2.12 Exercise at least the same level of fraud control in providing OS to ComSouth that BellSouth provides for its own OS.
- 8.2.13 Perform Billed Number Screening when handling Collect, Person-to-Person, and Billed-To-Third-Party calls.
- 8.2.14 Direct customer account and other similar inquiries to the customer service center designated by ComSouth.
- 8.3 Upon ComSouth's request BellSouth shall provide call records to ComSouth in accordance with Optional Daily Usage File (ODUF) standards.
- 8.4 The interface requirements shall conform to the interface specifications for the platform used to provide OS as long as the interface conforms to industry standards.
- 8.5 DA Service
- 8.5.1 DA Service provides local and non-local customer telephone number listings with the option to complete the call at the caller's direction separate and distinct from local switching.
- 8.5.2 DA Service shall provide up to two (2) listing requests per call, if available and if requested by ComSouth's customer. BellSouth shall provide caller-optional DA call completion service at rates set forth in BellSouth's GSST to one of the provided listings.
- 8.6 DA Service Updates. BellSouth shall update customer listings changes daily. These changes include:
 - 8.6.1 New customer connections;
 - 8.6.2 Customer disconnections;
 - 8.6.3 Customer address changes; and
 - 8.6.4 Non-listed and non-published numbers for use in emergencies.

9. Branding for Wholesale OCP and DA

- 9.1 BellSouth's branding feature provides a definable announcement to ComSouth's customers using BellSouth's DA/OCP prior to placing such customers in queue or connecting them to an available operator or automated operator system. This feature allows ComSouth to have its calls custom branded with ComSouth's name on whose behalf BellSouth is providing DA and/or OCP. Rates for the branding features are set forth in Exhibit D.
- 9.2 BellSouth offers three (3) branding options to ComSouth when ordering BellSouth's DA and OCP: BellSouth Branding, Unbranding and Custom Branding.

- 9.3 ComSouth's order for Custom Branding is considered firm ten (10) business days after BellSouth's receipt of the order. ComSouth may cancel its order more than ten (10) business days after BellSouth's receipt of the order. ComSouth shall notify BellSouth in writing and shall pay all charges per the order. For branding and unbranding via Originating Line Number Screening (OLNS), ComSouth must contact its Local Contract Manager to initiate the order via the OLNS Branding Order form.
- 9.4 Branding via OLNS
- 9.4.1 BellSouth Branding, Unbranding and Custom Branding are also available for DA, OCP or both via OLNS software. When utilizing this method of Unbranding or Custom Branding, ComSouth shall not be required to purchase dedicated trunking.
- 9.4.2 BellSouth Branding is the default branding offering.
- 9.4.3 For BellSouth to provide Unbranding or Custom Branding via OLNS software for OCP or for DA, ComSouth must have its OCN(s) and telephone numbers reside in BellSouth's Line Information Database (LIDB). To implement Unbranding and Custom Branding via OLNS software, ComSouth must submit a manual order form which requires, among other things, ComSouth's OCN and a forecast, pursuant to the appropriate BellSouth form provided, for the traffic volume anticipated for each BellSouth Traffic Operator Position System (TOPS) during the peak busy hour. ComSouth shall provide updates to such forecast on a quarterly basis and at any time such forecasted traffic volumes are expected to change significantly. Upon ComSouth's purchase of Unbranding or Custom Branding using OLNS software for any particular TOPS, all ComSouth customers served by that TOPS will receive the Unbranded "no announcement" or the Custom Branded announcement.
- 10. LIDB**
- 10.1 BellSouth LIDB stores current information on working telephone numbers and billing account numbers.
- 10.2 Where ComSouth is purchasing Resale services BellSouth shall utilize BellSouth's service order generated from ComSouth LSR's to populate LIDB with ComSouth's customer information. BellSouth provides access to information in its LIDB, including ComSouth customer information, to its LIDB customers via queries to LIDB.
- 10.2.1 When necessary for fraud control measures, BellSouth may perform additions, updates and deletions of ComSouth data to the LIDB (e.g., calling card deactivation).
- 10.2.2 ComSouth will not be charged a fee for LIDB storage services provided by BellSouth to ComSouth pursuant to this Attachment.
- 10.3 Responsibilities of the Parties
- 10.3.1 BellSouth will administer the data provided by ComSouth pursuant to this Agreement in the same manner as BellSouth administers its own data.

- 10.3.2 ComSouth is responsible for completeness and accuracy of the data being provided to BellSouth.
- 10.3.3 BellSouth shall not be responsible to ComSouth for any lost revenue which may result from BellSouth's administration of the LIDB pursuant to its established practices and procedures as they exist and as they may be changed by BellSouth in its sole discretion from time to time.
- 11. Revenue Accounting Office (RAO) Hosting**
 - 11.2 RAO Hosting is not required for resale in the BellSouth region.
- 12. Optional Daily Usage File (ODUF)**
 - 12.1 The ODUF Agreement with terms and conditions is included in this Attachment as Exhibit B. Rates for ODUF are as set forth in Exhibit D.
 - 12.2 BellSouth will provide ODUF service upon written request.
- 13. Enhanced Optional Daily Usage File (EODUF)**
 - 13.1 The EODUF service Agreement with terms and conditions is included in this Attachment as Exhibit C. Rates for EODUF are as set forth in Exhibit D.
 - 13.2 BellSouth will provide EODUF service upon written request.

EXCLUSIONS AND LIMITATIONS ON SERVICES AVAILABLE FOR RESALE (Note 4)

Type of Service	AL		FL		GA		KY		LA		MS		NC		SC		TN	
	Resale	Discount	Resale	Discount	Resale	Discount	Resale	Discount	Resale	Discount	Resale	Discount	Resale	Discount	Resale	Discount	Resale	Discount
1 Grandfathered Services (Note 1)	Yes	Yes	Yes	Yes	Yes	Yes	Yes	Yes	Yes	Yes	Yes	Yes	Yes	Yes	Yes	Yes	Yes	Yes
2 Promotions - > 90 Days(Note 2 &3)	Yes	Yes	Yes	Yes	Yes	Yes	Yes	Yes	Yes	Yes	Yes	Yes	Yes	Yes	Yes	Yes	Yes	Yes
3 Promotions - < 90 Days (Note 2 & 3)	Yes	No	Yes	No	Yes	No	Yes	No	Yes	No	Yes	No	Yes	No	Yes	No	Yes	No
4 Lifeline/Link Up Services	Yes	Yes	Yes	Yes	Yes	Yes	Yes	Yes	Yes	Yes	Yes	Yes	Yes	Yes	Yes	Yes	Yes	Yes
5 911/E911 Services	Yes	Yes	Yes	Yes	Yes	Yes	Yes	Yes	No	No	Yes	Yes	Yes	Yes	Yes	Yes	Yes	Yes
6 N11 Services (Note 1)	Yes	Yes	Yes	Yes	Yes	Yes	No	No	No	No	Yes	Yes	Yes	Yes	No	No	Yes	Yes
7 MemoryCall®Service	Yes	No	Yes	No	Yes	No	Yes	No	Yes	No	Yes	No	Yes	No	Yes	No	Yes	No
8 Mobile Services	Yes	No	Yes	No	Yes	No	Yes	No	Yes	No	Yes	No	Yes	No	Yes	No	Yes	No
9 Federal Subscriber Line Charges	Yes	No	Yes	No	Yes	No	Yes	No	Yes	No	Yes	No	Yes	No	Yes	No	Yes	No
10 Nonrecurring Charges	Yes	Yes	Yes	Yes	Yes	Yes	Yes	Yes	Yes	Yes	Yes	Yes	Yes	Yes	Yes	Yes	Yes	No
11 EUCL Charge	Yes	No	Yes	No	Yes	No	Yes	No	Yes	No	Yes	No	Yes	No	Yes	No	Yes	No
12 Public Telephone Access Svc(PTAS)	Yes	Yes	Yes	Yes	Yes	Yes	Yes	Yes	Yes	Yes	Yes	Yes	Yes	Yes	Yes	No	Yes	Yes
13 Inside Wire Maint Service Plan	Yes	No	Yes	No	Yes	No	Yes	No	Yes	No	Yes	No	Yes	No	Yes	No	Yes	No

Applicable Notes:

- Grandfathered services** can be resold only to existing subscribers of the grandfathered service.
- Where available for resale, **promotions** will be made available only to customers who would have qualified for the promotion had it been provided by BellSouth directly. Promotions shall be available only for the term set forth in the applicable tariff.
- Promotions shall be available only for the term set forth in the applicable tariff.
- Some of BellSouth's local exchange and toll Telecommunications Services are not available in certain central offices and areas.

Optional Daily Usage File

1. Upon written request from ComSouth, BellSouth will provide the ODUF service to ComSouth pursuant to the terms and conditions set forth in this section.
2. ComSouth shall furnish all relevant information required by BellSouth for the provision of the ODUF.
3. The ODUF feed provides ComSouth messages that were carried over the BellSouth network and processed by BellSouth for ComSouth.
4. Charges for ODUF will appear on ComSouth's monthly bills for the previous month's usage in arrears. The charges are as set forth in Exhibit D.
5. The ODUF feed will contain both rated and unrated messages. All messages will be in the standard Alliance for Telecommunications Industry Solutions (ATIS) Exchange Message Interface (EMI) record format.
6. ODUF Specifications
 - 6.1 ODUF Message to be Transmitted
 - 6.1.1 The following messages recorded by BellSouth will be transmitted to ComSouth:
 - 6.1.1.1 Message recording for per use/per activation type services (examples: Three Way Calling, Verify, Interrupt, Call Return, etc.);
 - 6.1.1.2 Measured local calls;
 - 6.1.1.3 Directory Assistance messages;
 - 6.1.1.4 IntraLATA Toll;
 - 6.1.1.5 WATS and 800 Service;
 - 6.1.1.6 N11;
 - 6.1.1.7 Information Service Provider Messages;
 - 6.1.1.8 OS Messages;
 - 6.1.1.9 OS Message Attempted Calls;
 - 6.1.1.10 Credit/Cancel Records; and
 - 6.1.1.11 Usage for Voice Mail Message Service.
 - 6.1.2 Rated Incollets (messages BellSouth receives from other revenue accounting offices) appear on ODUF. Rated Incollets will be intermingled with BellSouth recorded rated and unrated usage. Rated Incollets will not be packed separately.
 - 6.1.3 BellSouth will perform duplicate record checks on records processed to ODUF. Any duplicate messages detected will be deleted and not sent to ComSouth.
 - 6.1.4 In the event that ComSouth detects a duplicate on ODUF they receive from BellSouth, ComSouth will drop the duplicate message and will not return the duplicate to BellSouth.

6.2 ODUF Physical File Characteristics

- 6.2.1 ODUF will be distributed to ComSouth via Secure File Transfer Protocol (FTP). The ODUF feed will be a variable block format. The data on the ODUF feed will be in a non-compacted EMI format (one hundred seventy-five (175) byte format plus modules). It will be created on a daily basis Monday through Friday except holidays. Details such as dataset name and delivery schedule will be addressed during negotiations of the distribution medium. There will be a maximum of one (1) dataset per workday per OCN. If BellSouth determines the Secure FTP Mailbox is nearing capacity levels, BellSouth may move the customer to CONNECT:Direct file delivery.
- 6.2.2 If the customer is moved, CONNECT:Direct data circuits (private line or dial-up) will be required between BellSouth and ComSouth for the purpose of data transmission. Where a dedicated line is required, ComSouth will be responsible for ordering the circuit, overseeing its installation and coordinating the installation with BellSouth. ComSouth will also be responsible for any charges associated with this line. Equipment required on the BellSouth end to attach the line to the mainframe computer and to transmit messages successfully on an ongoing basis will be negotiated on an individual case basis. Any costs incurred for such equipment will be ComSouth's responsibility. Where a dial-up facility is required, dial circuits will be installed in the BellSouth data center by BellSouth and the associated charges assessed to ComSouth. Additionally, all message toll charges associated with the use of the dial circuit by ComSouth will be the responsibility of ComSouth. Associated equipment on the BellSouth end, including a modem, will be negotiated on an individual case basis between the Parties. All equipment, including modems and software, that is required on ComSouth's end for the purpose of data transmission will be the responsibility of ComSouth.
- 6.2.3 If ComSouth utilizes FTP for data file transmission, purchase of the FTP software will be the responsibility of ComSouth.

6.3 ODUF Packing Specifications

- 6.3.1 The data will be packed using ATIS EMI records. A pack will contain a minimum of one (1) message record or a maximum of ninety-nine thousand nine hundred and ninety-nine (99,999) message records plus a pack header record and a pack trailer record. One transmission can contain a maximum of ninety-nine (99) packs and a minimum of one (1) pack.
- 6.3.2 The OCN, From RAO, and Invoice Number will control the invoice sequencing. The From RAO will be used to identify to ComSouth which BellSouth RAO is sending the message. BellSouth and ComSouth will use the invoice sequencing to control data exchange. BellSouth will be notified of sequence failures identified by ComSouth and resend the data as appropriate.

6.4 ODUF Pack Rejection

- 6.4.1 ComSouth will notify BellSouth within one (1) business day of rejected packs (via the mutually agreed medium). Packs could be rejected because of pack

sequencing discrepancies or a critical edit failure on the Pack Header or Pack Trailer records (e.g., out-of-balance condition on grand totals, invalid data populated). Standard ATIS EMI error codes will be used. ComSouth will not be required to return the actual rejected data to BellSouth. Rejected packs will be corrected and retransmitted to ComSouth by BellSouth.

6.5 ODUF Control Data

6.5.1 ComSouth will send one confirmation record per pack that is received from BellSouth. This confirmation record will indicate ComSouth's receipt of the pack and the acceptance or rejection of the pack. Pack Status Code(s) will be populated using standard ATIS EMI error codes for packs that were rejected by ComSouth for reasons stated in the above section.

6.6 ODUF Testing

6.6.1 Upon request from ComSouth, BellSouth shall send ODUF test files to ComSouth. The Parties agree to review and discuss the ODUF file content and/or format. For testing of usage results, BellSouth shall request that ComSouth set up a production (live) file. The live test may consist of ComSouth's employees making test calls for the types of services ComSouth requests on ODUF. These test calls are logged by ComSouth, and the logs are provided to BellSouth. These logs will be used to verify the files. Testing will be completed within thirty (30) days from the date on which the initial test file was sent.

Enhanced Optional Daily Usage File

1. Upon written request from ComSouth, BellSouth will provide the EODUF service to ComSouth pursuant to the terms and conditions set forth in this section. EODUF will only be sent to existing ODUF subscribers who request the EODUF option.
2. ComSouth shall furnish all relevant information required by BellSouth for the provision of the EODUF.
3. The EODUF will provide usage data for local calls originating from resold Flat Rate Business and Residential Lines.
4. Charges for EODUF will appear on ComSouth's monthly bills for the previous month's usage in arrears. The charges are as set forth in Exhibit D.
5. All messages will be in the standard ATIS EMI record format.
6. Messages that error in the billing system of ComSouth will be the responsibility of ComSouth. If, however, ComSouth should encounter significant volumes of errored messages that prevent processing by ComSouth within its systems, BellSouth will work with ComSouth to determine the source of the errors and the appropriate resolution.
7. EODUF Specifications
 - 7.1 EODUF Usage To Be Transmitted
 - 7.1.1 The following messages recorded by BellSouth will be transmitted to ComSouth:
 - 7.1.1.1 Customer usage data for flat rated local calls originating from ComSouth's customer lines (1FB or 1FR). The EODUF record for flat rate messages will include:
 - 7.1.1.1.1 Date of Call
 - 7.1.1.1.2 From Number
 - 7.1.1.1.3 To Number
 - 7.1.1.1.4 Connect Time
 - 7.1.1.1.5 Conversation Time
 - 7.1.1.1.6 Method of Recording
 - 7.1.1.1.7 From RAO
 - 7.1.1.1.8 Rate Class
 - 7.1.1.1.9 Message Type
 - 7.1.1.1.10 Billing Indicators
 - 7.1.1.1.11 Bill to Number

- 7.1.2 BellSouth will perform duplicate record checks on EODUF records processed to ODUF. Any duplicate messages detected will be deleted and not sent to ComSouth.
- 7.1.3 In the event that ComSouth detects a duplicate on EODUF they receive from BellSouth, ComSouth will drop the duplicate message and will not return the duplicate to BellSouth.
- 7.2 EODUF Physical File Characteristics
- 7.2.1 EODUF feed will be distributed to ComSouth via FTP. The EODUF messages will be intermingled among ComSouth's ODUF messages. The EODUF will be a variable block format. The data on the EODUF will be in a non-compacted EMI format (one hundred seventy-five (175) byte format plus modules). It will be created on a daily basis Monday through Friday except holiday. If BellSouth determines the Secure FTP mailbox is nearing capacity levels, BellSouth may move the customer to CONNECT:Direct file delivery.
- 7.2.2 Data circuits (private line or dial-up) may be required between BellSouth and ComSouth for the purpose of data transmission. Where a dedicated line is required, ComSouth will be responsible for ordering the circuit, overseeing its installation and coordinating the installation with BellSouth. ComSouth will also be responsible for any charges associated with this line. Equipment required on the BellSouth end to attach the line to the mainframe computer and to transmit successfully ongoing will be negotiated on an individual case basis. Where a dial-up facility is required, dial circuits will be installed in the BellSouth data center by BellSouth and the associated charges assessed to ComSouth. Additionally, all message toll charges associated with the use of the dial circuit by ComSouth will be the responsibility of ComSouth. Associated equipment on the BellSouth end, including a modem, will be negotiated on an individual case basis between the Parties. All equipment, including modems and software, that is required on ComSouth's end for the purpose of data transmission will be the responsibility of ComSouth.
- 7.2.3 If ComSouth utilizes FTP for data file transmission, purchase of the FTP software will be the responsibility of ComSouth.
- 7.3 EODUF Packing Specifications
- 7.3.1 The data will be packed using ATIS EMI records. A pack will contain a minimum of one (1) message record or a maximum of ninety-nine thousand nine hundred and ninety-nine (99,999) message records plus a pack header record and a pack trailer record. One transmission can contain a maximum of ninety-nine (99) packs and a minimum of one (1) pack.
- 7.3.2 The OCN, From RAO, and Invoice Number will control the invoice sequencing. The From RAO will be used to identify to ComSouth which BellSouth RAO is sending the message. BellSouth and ComSouth will use the invoice sequencing to control data exchange. BellSouth will be notified of sequence failures identified by ComSouth and resend the data as appropriate.

RESALE DISCOUNTS & RATES - Georgia											Att: 1 Exh: D					
CATEGORY	RATE ELEMENTS	Interim	Zone	BCS	USOC	RATES(\$)				Svc Order Submitted Elec per LSR	Svc Order Submitted Manually per LSR	Incremental Charge - Manual Svc Order vs. Electronic-1st	Incremental Charge - Manual Svc Order vs. Electronic-Add'l	Incremental Charge - Manual Svc Order vs. Electronic-Disc 1st	Incremental Charge - Manual Svc Order vs. Electronic-Disc Add'l	
						Rec	Nonrecurring		Nonrecurring Disconnect							OSS Rates(\$)
							First	Add'l	First	Add'l	SOMEc	SOMAN	SOMAN	SOMAN	SOMAN	SOMAN
RESALE APPLICABLE DISCOUNTS																
	Residence %						20.30									
	Business %						17.30									
	CSAs %						17.30									
OPERATIONS SUPPORT SYSTEMS (OSS) - "REGIONAL RATES"																
NOTE: (1) CLEC should contact its contract negotiator if it prefers the "state specific" OSS charges as ordered by the State Commissions. The OSS charges currently contained in this rate exhibit are the BellSouth "regional" service ordering charges. CLEC may elect either the state specific Commission ordered rates for the service ordering charges, or CLEC may elect the regional service ordering charge, however, CLEC can not obtain a mixture of the two regardless if CLEC has an interconnection contract established in each of the 9 states.																
	OSS - Electronic Service Order Charge, Per Local Service Request (LSR) - Resale Only					SOMEc	3.50	0.00	3.50	0.00						
	OSS - Manual Service Order Charge, Per Local Service Request (LSR) - Resale Only					SOMAN	19.99	0.00	19.99	0.00						
ODUF/EODUF SERVICES																
OPTIONAL DAILY USAGE FILE (ODUF)																
	ODUF: Recording, per message						0.000007									
	ODUF: Message Processing, per message						0.002165									
	ODUF: Message Processing, per Magnetic Tape provisioned						36.02									
	ODUF: Data Transmission (CONNECT:DIRECT), per message						0.00010888									
ENHANCED OPTIONAL DAILY USAGE FILE (EODUF)																
	EODUF: Message Processing, per message						0.229077									
SELECTIVE CALL ROUTING USING LINE CLASS CODES (SCR-LCC)																
	Selective Routing Per Unique Line Class Code Per Request Per Switch						102.19	61.15	12.68	6.34						
DIRECTORY ASSISTANCE CUSTOM BRANDING ANNOUNCEMENT via OLNS SOFTWARE																
	Recording of DA Custom Branded Announcement						3,000.00	3,000.00								
	Loading of DA Custom Branded Announcement per Switch per OCN						1,170.00	1,170.00								
DIRECTORY ASSISTANCE UNBRANDING via OLNS SOFTWARE																
	Loading of DA per OCN (1 OCN per Order)						420.00	420.00								
	Loading of DA per Switch per OCN						16.00	16.00								
OPERATOR ASSISTANCE CUSTOM BRANDING ANNOUNCEMENT via OLNS SOFTWARE																
	Recording of Custom Branded OA Announcement						7,000.00	7,000.00								
	Loading of Custom Branded OA Announcement per shelf/NAV per OCN						500.00	500.00								
	Loading of OA Custom Branded Announcement per Switch per OCN						1,170.00	1,170.00								
OPERATOR ASSISTANCE UNBRANDING via OLNS SOFTWARE																
	Loading of OA per OCN (Regional)						1,200.00	1,200.00								

Attachment 2

Other Services

TABLE OF CONTENTS

1 Introduction.....3

2 White Pages Listings4

Rates Exhibit A

ACCESS TO OTHER SERVICES

1 Introduction

- 1.1 This Attachment sets forth the rates, terms and conditions for other facilities and services BellSouth makes available to ComSouth (Other Services). Additionally, the provision of a particular Other Service may require ComSouth to purchase other Network Elements or services. In the event of a conflict between this Attachment and any other section or provision of this Agreement, the provisions of this Attachment shall control.
- 1.2 The rates for Other Services are set forth in Exhibit A. If no rate is identified in this Agreement, the rate will be as set forth in the applicable BellSouth tariff or as negotiated by the Parties upon request by either Party. If ComSouth purchases service(s) from a tariff, all terms and conditions and rates as set forth in such tariff shall apply. A one-month minimum billing period shall apply to all Network Elements, Combinations and Other Services.
- 1.3 In some cases, Commissions have ordered BellSouth to separate its disconnect costs and its installation costs into two separate nonrecurring charges. Accordingly, unless otherwise noted in this Agreement, the Commission ordered disconnect charges will be applied at the time the disconnect activity is performed by BellSouth, regardless of whether or not a disconnect order is issued by ComSouth. Disconnect charges are set forth in the rate exhibit of this Attachment. ComSouth may purchase and use Network Elements and Other Services from BellSouth in accordance with 47 C.F.R § 51.309.
- 1.4 The Parties shall comply with the requirements as set forth in the technical references within this Attachment 2.
- 1.5 Terms and conditions for order cancellation charges and Service Date Advancement Charges will apply in accordance with Attachment 6 and are incorporated herein by this reference. The charges shall be as set forth in Exhibit A.
- 1.6 Ordering Guidelines and Processes
- 1.6.1 For information regarding Ordering Guidelines and Processes for various Network Elements, Combinations and Other Services, ComSouth should refer to the “Guides” section of the BellSouth Interconnection Web site.
- 1.6.2 Additional information may also be found in the individual CLEC Information Packages, located at the “CLEC UNE Products” on BellSouth’s Interconnection Web site.

2 White Pages Listings

- 2.1 BellSouth shall provide ComSouth and its customers access to white pages directory listings under the following terms:
- 2.1.1 Listings. ComSouth shall provide all new, changed and deleted listings on a timely basis and BellSouth or its agent will include ComSouth residential and business customer listings in the appropriate White Pages (residential and business) or alphabetical directories in the geographic areas covered by this Agreement. Directory listings will make no distinction between ComSouth and BellSouth customers. ComSouth shall provide listing information in accordance with the procedures set forth in The BellSouth Business Rules for Local Ordering found at BellSouth's Interconnection Services Web site.
- 2.1.2 Unlisted/Non-Published Customers. ComSouth will be required to provide to BellSouth the names, addresses and telephone numbers of all ComSouth customers who wish to be omitted from directories. Unlisted/Non-Published listings will be subject to the rates as set forth in BellSouth's GSST and shall not be subject to wholesale discount.
- 2.1.3 Inclusion of ComSouth Customers in Directory Assistance Database. BellSouth will include and maintain ComSouth customer listings in BellSouth's DA databases. ComSouth shall provide such Directory Assistance listings to BellSouth at no charge.
- 2.1.4 Listing Information Confidentiality. BellSouth will afford ComSouth's directory listing information the same level of confidentiality that BellSouth affords its own directory listing information.
- 2.1.5 Additional and Designer Listings. Additional and designer listings will be offered by BellSouth at tariffed rates as set forth in BellSouth's GSST and shall not be subject to the wholesale discount.
- 2.1.6 Rates. So long as ComSouth provides listing information to BellSouth as set forth in Section 2.1.2 above, BellSouth shall provide to ComSouth one (1) basic White Pages directory listing per ComSouth customer at no charge other than applicable service order charges as set forth in BellSouth's tariffs. Except in the case of a LSR submitted solely to port a number from BellSouth, if such listing is requested on the initial LSR associated with the request for services, a single manual service order charge or electronic service order charge, as appropriate, as described in Attachment 6, will apply to both the request for service and the request for the directory listing. Where a subsequent LSR is placed solely to request a directory listing, or is placed to port a number and request a directory listing, separate service order charges as set forth in BellSouth's tariffs shall apply, as well as the

manual service order charge or the electronic service order charge, as appropriate, as described in Attachment 6.

- 2.2 Directories. BellSouth or its agent shall make available White Pages directories to ComSouth customer at no charge or as specified in a separate agreement between ComSouth and BellSouth's agent.
- 2.3 Procedures for submitting ComSouth Subscriber Listing Information (SLI) are found in The BellSouth Business Rules for Local Ordering found at BellSouth's Interconnection Services Web site.
- 2.3.1 ComSouth authorizes BellSouth to release all ComSouth SLI provided to BellSouth by ComSouth to qualifying third parties. Such ComSouth SLI shall be intermingled with BellSouth's own customer listings and listings of any other CLEC that has authorized a similar release of SLI.
- 2.3.2 No compensation shall be paid to ComSouth for BellSouth's receipt of ComSouth SLI, or for the subsequent release to third parties of such SLI. In addition, to the extent BellSouth incurs costs to modify its systems to enable the release of ComSouth's SLI, or costs on an ongoing basis to administer the release of ComSouth SLI, ComSouth shall pay to BellSouth its proportionate share of the reasonable costs associated therewith. At any time that costs may be incurred to administer the release of ComSouth's SLI, ComSouth will be notified. If ComSouth does not wish to pay its proportionate share of these reasonable costs, ComSouth may instruct BellSouth that it does not wish to release its SLI to independent publishers, and ComSouth shall amend this Agreement accordingly. ComSouth will be liable for all costs incurred until the effective date of the agreement.
- 2.3.3 Neither BellSouth nor any agent shall be liable for the content or accuracy of any SLI provided by ComSouth under this Agreement. ComSouth shall indemnify, except to the extent caused by BellSouth's gross negligence or willful misconduct, hold harmless and defend BellSouth and its agents from and against any damages, losses, liabilities, demands, claims, suits, judgments, costs and expenses (including but not limited to reasonable attorneys' fees and expenses) arising from BellSouth's tariff obligations or otherwise and resulting from or arising out of any third party's claim of inaccurate ComSouth listings or use of the SLI provided pursuant to this Agreement. BellSouth may forward to ComSouth any complaints received by BellSouth relating to the accuracy or quality of ComSouth listings.
- 2.3.4 Listings and subsequent updates will be released consistent with BellSouth system changes and/or update scheduling requirements.

UNBUNDLED NETWORK ELEMENTS - Georgia											Att: 2 Exh: A				
CATEGORY	RATE ELEMENTS	Interim	Zone	BCS	USOC	RATES(\$)				Svc Order Submitted Elec per LSR	Svc Order Submitted Manually per LSR	Incremental Charge - Manual Svc Order vs. Electronic-1st	Incremental Charge - Manual Svc Order vs. Electronic-Add'l	Incremental Charge - Manual Svc Order vs. Electronic-Disc 1st	Incremental Charge - Manual Svc Order vs. Electronic-Disc Add'l
						Rec	Nonrecurring		Nonrecurring Disconnect						
							First	Add'l	First	Add'l	SOMEc	SOMAN	SOMAN	SOMAN	SOMAN
The "Zone" shown in the sections for stand-alone loops or loops as part of a combination refers to Geographically Deaveraged UNE Zones. To view Geographically Deaveraged UNE Zone Designations by Central Office, refer to internet Website: http://www.interconnection.bellsouth.com/become_a_clec/html/interconnection.htm															
OPERATIONS SUPPORT SYSTEMS (OSS) - "REGIONAL RATES"															
NOTE: (1) CLEC should contact its contract negotiator if it prefers the "state specific" OSS charges as ordered by the State Commissions. The OSS charges currently contained in this rate exhibit are the BellSouth "regional" service ordering charges. CLEC may elect either the state specific Commission ordered rates for the service ordering charges, or CLEC may elect the regional service ordering charge, however, CLEC can not obtain a mixture of the two regardless if CLEC has a interconnection contract established in each of the 9 states.															
NOTE: (2) Any element that can be ordered electronically will be billed according to the SOMEc rate listed in this category. Please refer to BellSouth's Local Ordering Handbook (LOH) to determine if a product can be ordered electronically. For those elements that cannot be ordered electronically at present per the LOH, the listed SOMEc rate in this category reflects the charge that would be billed to a CLEC once electronic ordering capabilities come on-line for that element. Otherwise, the manual ordering charge, SOMAN, will be applied to a CLECs bill when it submits an LSR to BellSouth.															
	OSS - Electronic Service Order Charge, Per Local Service Request (LSR) - UNE Only				SOMEc		3.50	0.00	3.50	0.00					
	OSS - Manual Service Order Charge, Per Local Service Request (LSR) - UNE Only				SOMAN		11.71	0.00	6.13	0.00					
	OSS - Electronic Service Order Charge, Per Local Service Request (LSR) - UNE Only Per First 1000 Orders Per Month				SOMGA	0.00									
UNE SERVICE DATE ADVANCEMENT CHARGE															
NOTE: The Expedite charge will be maintained commensurate with BellSouth's FCC No.1 Tariff, Section 5 as applicable.															
	UNE Expedite Charge per Circuit or Line Assignable USOC, per Day			UAL, UEANL, UCL, UEF, UDC, UDF, UEQ, UDL, UENTW, UDN, UEA, UHL, ULC, USL, U1T12, U1T48, U1TD1, U1TD3, U1TDX, U1TO3, U1TS1, U1TVX, UC1BC, UC1BL, UC1CC, UC1CL, UC1DC, UC1DL, UC1EC, UC1EL, UC1FC, UC1FL, UC1GC, UC1GL, UC1HC, UC1HL, UDL12, UDL48, UDLO3, UDLSX, UE3, ULD12, ULD48, ULDD1, ULDD3, ULDDX, ULDO3, ULDS1, ULDVX, UNC1X, UNC3X, UNCDX, UNCNX, UNCSX, UNCVX, UNLD1, UNLD3, UXTD1, UXTD3, UXTS1, U1TUC, U1TUD, U1TUB, U1TUA, NTCVG, NTCUD, NTCDD1	SDASP		200.00								
ORDER MODIFICATION CHARGE															
	Order Modification Charge (OMC)						26.21	0.00	0.00	0.00					
LNP Query Service															
	LNP Charge Per query					0.0008034									
	LNP Service Establishment Manual						12.49			11.09					
	LNP Service Provisioning with Point Code Establishment						574.87	293.68	251.47	184.91					

UNBUNDLED NETWORK ELEMENTS - Georgia											Att: 2 Exh: A											
CATEGORY	RATE ELEMENTS	Interim	Zone	BCS	USOC	RATES(\$)	Svc Order Submitted Elec per LSR	Svc Order Submitted Manually per LSR	Incremental Charge - Manual Svc Order vs. Electronic-1st	Incremental Charge - Manual Svc Order vs. Electronic-Disc Add'l	Incremental Charge - Manual Svc Order vs. Electronic-Disc 1st	Incremental Charge - Manual Svc Order vs. Electronic-Disc Add'l	OSS Rates(\$)									
													Rec	Nonrecurring		Nonrecurring Disconnect		SOMEc	SOMAN	SOMAN	SOMAN	SOMAN
													First	Add'l	First	Add'l						

Attachment 3
Network Interconnection

TABLE OF CONTENTS

1	General	3
2	Definitions: (For the purpose of this Attachment)	3
3	Network Interconnection	5
4	Interconnection Trunk Group Architectures	7
5	Network Design And Management For Interconnection.....	13
6	Forecasting for Trunk Provisioning.....	14
7	Local Dialing Parity	16
8	Interconnection Compensation.....	16
9	Ordering Charges.....	22
10	Basic 911 and E911 Interconnection	22
11	SS7 Network Interconnection	23
	Rates	Exhibit A
	Basic Architecture	Exhibit B
	One Way Architecture	Exhibit C
	Two Way Architecture	Exhibit D
	Supergroup Architecture	Exhibit E

NETWORK INTERCONNECTION

1 General

- 1.1 The Parties shall provide interconnection with each other's networks for the transmission and routing of telephone exchange service (Local Traffic), ISP-Bound Traffic, and exchange access (Switched Access Traffic) on the following terms:

2 Definitions: (For the purpose of this Attachment)

For purposes of this attachment only, the following terms shall have the definitions set forth below:

- 2.1 **Automatic Location Identification (ALI)** is a feature by which the address associated with the calling party's telephone number (ANI) is forwarded to the PSAP for display. Access to the ALI database is described in Attachment 2 to this Agreement.
- 2.2 **Automatic Number Identification (ANI)** corresponds to the seven-digit telephone number assigned by the serving local exchange carrier.
- 2.3 **BellSouth Trunk Group** is defined as a one-way trunk group carrying BellSouth originated traffic to be terminated by ComSouth.
- 2.4 **911 Service** is as described in this Attachment.
- 2.5 **Call Termination** has the meaning set forth for "termination" in 47 C.F.R. § 51.701(d).
- 2.6 **Call Transport** has the meaning set forth for "transport" in 47 C.F.R. § 51.701(c).
- 2.7 **Call Transport and Termination** is used collectively to mean the switching and transport functions from the Interconnection Point to the last point of switching.
- 2.8 **Common (Shared) Transport** is defined as the transport of the originating Party's traffic by the terminating Party over the terminating Party's common (shared) facilities between (1) the terminating Party's tandem switch and end office switch, (2) between the terminating Party's tandem switches, and/or (3) between the terminating Party's host and remote end office switches. All switches referred herein must be entered into the The Telcordia® LERG™ Routing Guide (LERG).
- 2.9 **Dedicated Interoffice Facility** is defined as a switch transport facility between a Party's Serving Wire Center and the first point of switching within the LATA on the other Party's network.
- 2.10 **End Office Switching** is defined as the function that establishes a communications path between the trunk side and line side of the End Office switch.

- 2.11 **Fiber Meet** is an interconnection arrangement whereby the Parties physically interconnect their networks via an optical fiber interface at which one Party's facilities, provisioning, and maintenance responsibility begins and the other Party's responsibility ends.
- 2.12 **Final Trunk Group** is defined as the last choice trunk group between two (2) switches for which there is no alternate route.
- 2.13 **Integrated Services Digital Network User Part (ISUP)** is a message protocol to support call set-up and release for interoffice voice connections over SS7 signaling.
- 2.14 **Interconnection Point (IP)** is the physical telecommunications equipment interface that interconnects the networks of BellSouth and ComSouth.
- 2.15 **IntraLATA Toll Traffic** is as defined in this Attachment.
- 2.16 **ISP-Bound Traffic** is as defined in this Attachment.
- 2.17 **Local Channel** is defined as a switched transport facility between a Party's Interconnection Point and the IP's Serving Wire Center.
- 2.18 **Local Traffic** is as defined in this Attachment.
- 2.19 **Public Safety Answering Point (PSAP)** is the answering location for 911 calls.
- 2.20 **Selective Routing (SR)** is a standard feature that routes an E911 call from the tandem to the designated PSAP based upon the address of the ANI of the calling party.
- 2.21 **Serving Wire Center (SWC)** is defined as the wire center owned by one Party from which the other Party would normally obtain dial tone for its IP.
- 2.22 **Signaling System 7 (SS7)/Common Channel Signaling 7 (CCS7)** is an out-of-band signaling system used to provide basic routing information, call set-up and other call termination functions. Signaling is removed from the voice channel and put on a separate data network.
- 2.23 **Tandem Switching** is defined as the function that establishes a communications path between two switching offices through a third switching office through the provision of trunk side to trunk side switching.
- 2.24 **Transit Traffic** is traffic originating on ComSouth's network that is switched and/or transported by BellSouth and delivered to a third party's network, or traffic originating on a third party's network that is switched and/or transported by BellSouth and delivered to ComSouth's network.

3 Network Interconnection

- 3.1 This Attachment pertains only to the provision of network interconnection where ComSouth owns, leases from a third party or otherwise provides its own switch(es).
- 3.2 Network interconnection may be provided by the Parties at any technically feasible point within BellSouth's network. Requests to BellSouth for interconnection at points other than as set forth in this Attachment may be made through the Bona Fide Request/New Business Request (BFR/NBR) Process set forth in Attachment 11.
- 3.2.1 Each Party is responsible for providing, engineering and maintaining the network on its side of the IP. The IP must be located within BellSouth's serving territory in the LATA in which traffic is originating. The IP determines the point at which the originating Party shall pay the terminating Party for the Call Transport and Termination of Local Traffic, ISP-Bound Traffic and IntraLATA Toll Traffic. In selecting the IP, both Parties will act in good faith and select the point that is most efficient for both Parties.
- 3.2.2 Pursuant to the provisions of this Attachment, the location of the initial IP in a given LATA shall be established by mutual agreement of the Parties. Subject to the requirements for installing additional IPs, as set forth below, any IPs existing prior to the Effective Date of the Agreement will be accepted as initial IPs and will not require re-grooming. When the Parties mutually agree to utilize two-way interconnection trunk groups for the exchange of Local Traffic, ISP-Bound Traffic and IntraLATA Toll Traffic between each other, the Parties shall mutually agree to the location of IP(s). If the Parties are unable to agree to a mutual initial IP, each Party, as originating Party, shall establish a single IP in the LATA for the delivery of its originated Local Traffic, ISP-Bound Traffic and IntraLATA Toll Traffic to the other Party for Call Transport and Termination by the terminating Party.
- 3.2.3 Additional IP(s) in a LATA may be established by mutual agreement of the Parties. Notwithstanding the foregoing, additional IP(s) in a particular LATA shall be established, at the request of either Party, when the Local Traffic and ISP-Bound Traffic exceeds eight point nine (8.9) million minutes per month for three (3) consecutive months at the proposed location of the additional IP. BellSouth will not request the establishment of an IP in a BellSouth Central Office where physical or virtual collocation space is not available or where BellSouth fiber connectivity is not available. When the Parties agree to utilize two-way interconnection trunk groups for the exchange of Local Traffic, ISP-Bound Traffic and IntraLATA Toll Traffic the Parties must agree to the location of the IP(s).
- 3.3 Interconnection via Dedicated Facilities
- 3.3.1 Local Channel Facilities. As part of Call Transport and Termination, the originating Party may obtain Local Channel facilities from the terminating Party.

The percentage of Local Channel facilities utilized for Local Traffic and ISP-Bound Traffic shall be determined based upon the application of the Percent Local Facility (PLF) Factor as set forth in this Attachment. The charges applied to the percentage of Local Channel facilities used for Local Traffic and ISP-Bound Traffic as determined by the PLF factor are as set forth in Exhibit A. The remaining percentage of Local Channel facilities shall be billed at BellSouth's intrastate Access Services Tariff or BellSouth's FCC No. 1 Tariff rates.

- 3.3.2 Dedicated Interoffice Facilities. As a part of Call Transport and Termination, the originating Party may obtain Dedicated Interoffice Facilities from the terminating Party. The percentage of Dedicated Interoffice Facilities utilized for Local Traffic and ISP-Bound Traffic shall be determined based upon the application of the PLF factor as set forth in this Attachment. The charges applied to the percentage of the Dedicated Interoffice Facilities used for Local Traffic and ISP-Bound Traffic as determined by the PLF factor are as set forth in Exhibit A. The remaining percentage of the Dedicated Interoffice Facilities shall be billed at BellSouth's intrastate Access Services Tariff or BellSouth's FCC No. 1 Tariff rates.
- 3.4 Fiber Meet. Notwithstanding Sections 3.2.1, 3.2.2, and 3.2.3 above, if ComSouth elects to establish interconnection with BellSouth pursuant to a Fiber Meet Local Channel, ComSouth and BellSouth shall jointly engineer, operate and maintain a Synchronous Optical Network (SONET) transmission system by which they shall interconnect their transmission and routing of Local Traffic and ISP-Bound Traffic via a Local Channel at either the DS1 or DS3 level. The Parties shall work jointly to determine the specific transmission system. However, ComSouth's SONET transmission system must be compatible with BellSouth's equipment, and the Data Communications Channel (DCC) must be turned off.
- 3.4.1 Each Party, at its own expense, shall procure, install and maintain the agreed upon SONET transmission system in its network.
- 3.4.2 The Parties shall agree to a Fiber Meet point between the BellSouth Serving Wire Center and the ComSouth Serving Wire Center. The Parties shall deliver their fiber optic facilities to the Fiber Meet point with sufficient spare length to reach the fusion splice point for the Fiber Meet point. BellSouth shall, at its own expense, provide and maintain the fusion splice point for the Fiber Meet. A building type CLLI code will be established for each Fiber Meet point. All orders for interconnection facilities from the Fiber Meet point shall indicate the Fiber Meet point as the originating point for the facility.
- 3.4.3 Upon verbal request by ComSouth, BellSouth shall allow ComSouth access to the fusion splice point for the Fiber Meet point for maintenance purposes on ComSouth's side of the Fiber Meet point.
- 3.4.4 Neither Party shall charge the other for its Local Channel portion of the Fiber Meet facility used exclusively for Local Traffic and ISP-Bound Traffic. The percentage of Local Channel facilities utilized for Local Traffic and ISP-Bound Traffic shall be

determined based upon the application of the PLF factor as set forth in this Attachment. The charges applied to the percentage of Local Channel facilities used for Local Traffic and ISP-Bound Traffic as determined by the PLF factor are as set forth in Exhibit A. The remaining percentage of Local Channel facilities shall be billed at BellSouth's applicable access tariff rates. Charges for switched and special access services shall be billed in accordance with the applicable BellSouth intrastate Access Services Tariff and or BellSouth's FCC No. 1 Tariff.

4 Interconnection Trunk Group Architectures

- 4.1 BellSouth and ComSouth shall establish interconnecting trunk groups and trunk group configurations between networks, including the use of one-way or two-way trunks in accordance with the following provisions set forth in this Attachment. For trunking purposes, traffic will be routed based on the digits dialed by the originating end user and in accordance with the LERG.
- 4.2 ComSouth shall establish an interconnection trunk group(s) to at least one (1) BellSouth access tandem within the LATA for the delivery of ComSouth's originated Local Traffic, ISP-Bound Traffic and IntraLATA Toll Traffic and for the receipt and delivery of Transit Traffic. To the extent ComSouth desires to deliver Local Traffic, ISP-Bound Traffic, IntraLATA Toll Traffic and/or Transit Traffic to BellSouth access tandems within the LATA, other than the tandems(s) to which ComSouth has established interconnection trunk groups, ComSouth shall pay the appropriate rates for Multiple Tandem Access, as described in this Attachment.
- 4.2.1 Notwithstanding the forgoing, ComSouth shall establish an interconnection trunk group(s) to all BellSouth access and local tandems in the LATA where ComSouth has homed (i.e., assigned) its NPA/NXXs. ComSouth shall home its NPA/NXXs on the BellSouth tandems that serve the exchange rate center areas to which the NPA/NXXs are assigned. The specified exchange rate center assigned to each BellSouth tandem is defined in the LERG. ComSouth shall enter its NPA/NXX access and/or local tandem homing arrangements into the LERG.
- 4.3 Switched access traffic will be delivered to and from IXCs based on ComSouth's NXX access tandem homing arrangement as specified by ComSouth in the LERG.
- 4.4 Any ComSouth interconnection request that (1) deviates from the interconnection trunk group architectures as described in this Agreement, (2) affects traffic delivered to ComSouth from a BellSouth switch, and (3) requires special BellSouth switch translations and other network modifications will require ComSouth to submit a BFR/NBR via the BFR/NBR Process as set forth in Attachment 11.
- 4.5 Recurring and nonrecurring rates associated with interconnecting trunk groups between BellSouth and ComSouth are set forth in Exhibit A. To the extent a rate associated with the interconnecting trunk group is not set forth in Exhibit A, the

rate shall be as set forth in the appropriate BellSouth intrastate Access Services Tariff or BellSouth's FCC No. 1 Tariff.

- 4.6 For two-way trunk groups that carry only both Parties' Local Traffic, the Parties shall be compensated at fifty percent (50%) of the nonrecurring and recurring rates for dedicated trunks and DS1 facilities. ComSouth shall be responsible for ordering and paying for any two-way trunks carrying Transit Traffic.
- 4.7 All trunk groups will be provisioned as SS7 capable where technically feasible. If SS7 is not technically feasible, multi-frequency (MF) protocol signaling shall be used.
- 4.8 In cases where ComSouth is also an IXC, the IXC's Feature Group D (FG D) trunk group(s) must remain separate from the local interconnection trunk group(s).
- 4.9 Each Party shall order interconnection trunks and trunk group including trunk and trunk group augmentations via the Access Service Request (ASR) process. A Firm Order Confirmation (FOC) shall be returned to the ordering Party, after receipt of a valid, error free ASR, within the timeframes set forth in each state's applicable Performance Measures. Notwithstanding the foregoing, blocking situations and projects shall be managed through BellSouth's Carrier Interconnection Switching Center (CISC) Project Management Group and ComSouth's equivalent trunking group, and FOCs for such orders shall be returned in the timeframes applicable to the project. A project is defined as (1) a new trunk group or (2) a request for more than one hundred ninety-two (192) trunks on a single or multiple group(s) in a given BellSouth local calling area.
- 4.10 Interconnection Trunk Groups for Exchange of Local Traffic and Transit Traffic
- 4.10.1 Upon mutual agreement of the Parties in a joint planning meeting, the Parties shall exchange Local Traffic on two-way interconnection trunk group(s) with the quantity of trunks being mutually determined and the provisioning being jointly coordinated. Furthermore, the Parties shall agree upon the IP(s) for two-way interconnection trunk groups transporting both Parties' Local Traffic, ISP-Bound Traffic and IntraLATA Toll Traffic. ComSouth shall order such two-way trunks via the ASR process. BellSouth will use the Trunk Group Service Request (TGSR) to request changes in trunking. Furthermore, the Parties shall jointly review trunk performance and forecasts in accordance with Section 6 below. The Parties' use of two-way interconnection trunk groups for the transport of Local Traffic, ISP-Bound Traffic and IntraLATA Toll Traffic between the Parties does not preclude either Party from establishing additional one-way interconnection trunks for the delivery of its originated Local Traffic, ISP-Bound Traffic and IntraLATA Toll Traffic to the other Party. Other trunk groups for operator services, directory assistance and intercept must be established pursuant to BellSouth's intrastate Access Services Tariff and/or BellSouth's FCC No. 1 Tariff.

- 4.10.2 BellSouth Access Tandem Interconnection. BellSouth Access Tandem interconnection at a single Access Tandem provides access to those End Offices subtending that access tandem (Intratandem Access). Access Tandem interconnection is available for any of the following access tandem architectures:
- 4.10.2.1 Basic Architecture. In the basic architecture, ComSouth's originating Local Traffic, ISP-Bound Traffic and IntraLATA Toll Traffic and originating and terminating Transit Traffic is transported on a single two-way trunk group between ComSouth and BellSouth Access Tandem(s) within a LATA to provide Intratandem Access. This trunk group carries Transit Traffic between ComSouth and ICOs, IXCs, other CLECs, CMRS providers that have a Meet Point Billing arrangement with BellSouth, and other network providers with which ComSouth desires to exchange traffic. This trunk group also carries ComSouth originated Transit Traffic transiting a single BellSouth Access Tandem destined to third party tandems such as an ICO tandem or other CLEC tandem. BellSouth originated Local Traffic, ISP-Bound Traffic and IntraLATA Toll Traffic is transported on a separate single one-way trunk group terminating to ComSouth. The LERG contains current routing and tandem serving arrangements. The basic Architecture is illustrated in Exhibit B.
- 4.10.2.2 One-Way Trunk Group Architecture. In one-way trunk group architecture, the Parties interconnect using three (3) separate trunk groups. A one-way trunk group provides Intratandem Access for ComSouth-originated Local Traffic, ISP-Bound Traffic and IntraLATA Toll Traffic destined for BellSouth end users. A second one-way trunk group carries BellSouth-originated Local Traffic, ISP-Bound Traffic and IntraLATA Toll Traffic destined for ComSouth end users. A two-way trunk group provides Intratandem Access for ComSouth's originating and terminating Transit Traffic. This trunk group carries Transit Traffic between ComSouth and ICOs, IXCs, other CLECs, CMRS providers that have a Meet Point Billing arrangement with BellSouth, and other network providers with which ComSouth exchanges traffic. This trunk group also carries ComSouth originated Transit Traffic transiting a single BellSouth Access Tandem destined to third party tandems such as an ICO tandem or other CLEC tandem. BellSouth originated Local Traffic, ISP-Bound Traffic and IntraLATA Toll Traffic is transported on a separate single one-way trunk group terminating to ComSouth. The LERG contains current routing and tandem serving arrangements. The one-way trunk group architecture is illustrated in Exhibit C.
- 4.10.2.3 Two-Way Trunk Group Architecture. The two-way trunk group Architecture establishes one (1) two-way trunk group to provide Intratandem Access for the exchange of Local Traffic, ISP-Bound Traffic and IntraLATA Toll Traffic between ComSouth and BellSouth. In addition, a separate two-way transit trunk group must be established for ComSouth's originating and terminating Transit Traffic. This trunk group carries Transit Traffic between ComSouth and ICOs, IXCs, other CLECs, CMRS providers that have a Meet Point Billing arrangement with BellSouth, and other network providers with which ComSouth exchanges traffic.

This trunk group also carries ComSouth originated Transit Traffic transiting a single BellSouth Access Tandem destined to third party tandems such as an ICO tandem or other CLEC tandem. BellSouth originated traffic may, in order to prevent or remedy traffic blocking situations, be transported on a separate single one-way trunk group terminating to ComSouth. However, where ComSouth is responsive in a timely manner to BellSouth's transport needs for its originated traffic, BellSouth originating traffic will be placed on the two-way Local Traffic trunk group carrying ISP-Bound Traffic and IntraLATA Toll Traffic. The LERG contains current routing and tandem serving arrangements. The two-way trunk group architecture is illustrated in Exhibit D.

4.10.2.4 Supergroup Architecture. In the supergroup architecture, the Parties' Local Traffic, ISP-Bound Traffic and IntraLATA Toll Traffic and ComSouth's Transit Traffic are exchanged on a single two-way trunk group between ComSouth and BellSouth to provide Intratandem Access to ComSouth. This trunk group carries Transit Traffic between ComSouth and ICOs, IXCs, other CLECs, CMRS providers that have a Meet Point Billing arrangement with BellSouth, and other network providers with which ComSouth desires to exchange traffic. This trunk group also carries ComSouth originated Transit Traffic transiting a single BellSouth Access Tandem destined to third party tandems such as an ICO tandem or other CLEC tandem. BellSouth originated traffic may, in order to prevent or remedy traffic blocking situations, be transported on a separate single one-way trunk group terminating to ComSouth. However, where ComSouth is responsive in a timely manner to BellSouth's transport needs for its originated traffic, BellSouth originating traffic will be placed on the Supergroup. Other trunk groups for operator services, directory assistance, emergency services and intercept must be established pursuant to the applicable BellSouth tariff if service is requested. The LERG contains current routing and tandem serving arrangements. The supergroup architecture is illustrated in Exhibit E.

4.10.2.5 Multiple Tandem Access (MTA) Interconnection

4.10.2.5.1 Where ComSouth does not choose access tandem interconnection at every BellSouth Access Tandem within a LATA, ComSouth must utilize BellSouth's MTA interconnection. To utilize MTA ComSouth must establish an interconnection trunk group(s) at a minimum of one (1) BellSouth Access Tandem within each LATA as required. BellSouth will route ComSouth's originated Local Traffic, ISP-Bound Traffic and IntraLATA Toll Traffic for LATA wide transport and termination. ComSouth must also establish an interconnection trunk group(s) at all BellSouth Access Tandems where ComSouth NXXs are homed as described in Section 4.2.1 above. If ComSouth does not have NXXs homed at any particular BellSouth Access Tandem within a LATA and elects not to establish an interconnection trunk group(s) at such BellSouth Access Tandem, ComSouth can order MTA in each BellSouth Access Tandem within the LATA where it does have an interconnection trunk group(s) and BellSouth will terminate ComSouth's Local Traffic, ISP-Bound Traffic and IntraLATA Toll Traffic to end users served

through those BellSouth Access Tandems where ComSouth does not have an interconnection trunk group(s). MTA shall be provisioned in accordance with BellSouth's Ordering Guidelines.

- 4.10.2.5.2 ComSouth may also utilize MTA to route its originated Transit Traffic; provided, however, that MTA may not be utilized to route switched access traffic that transits the BellSouth network to an IXC. Switched access traffic originated by or terminated to ComSouth will be delivered to and from IXCs based on ComSouth's NXX access tandem homing arrangement as specified by ComSouth in the LERG.
- 4.10.2.5.3 Compensation for MTA shall be at the applicable tandem switching and transport charges specified in Exhibit A and shall be billed in addition to any Call Transport and Termination charges.
- 4.10.2.5.4 To the extent ComSouth does not purchase MTA in a LATA served by multiple Access Tandems, ComSouth must establish an interconnection trunk group(s) to every Access Tandem in the LATA to serve the entire LATA. To the extent ComSouth routes its traffic in such a way that utilizes BellSouth's MTA service without properly ordering MTA, ComSouth shall pay BellSouth the associated MTA charges.

4.10.3 Local Tandem Interconnection

- 4.10.3.1 Local Tandem Interconnection arrangement allows ComSouth to establish an interconnection trunk group(s) at BellSouth local tandems for: (1) the delivery of ComSouth-originated Local Traffic and ISP-Bound Traffic transported and terminated by BellSouth to BellSouth End Offices served by those BellSouth local tandems, and (2) for local Transit Traffic transported by BellSouth for third party network providers who have also established an interconnection trunk group(s) at those BellSouth local tandems.
- 4.10.3.2 When a specified local calling area is served by more than one (1) BellSouth local tandem, ComSouth must designate a "home" local tandem for each of its assigned NPA/NXXs and establish trunk connections to such local tandems. Additionally, ComSouth may choose to establish an interconnection trunk group(s) at the BellSouth local tandems where it has no codes homing but is not required to do so. ComSouth may deliver Local Traffic and ISP-Bound Traffic to a "home" BellSouth local tandem that is destined for other BellSouth or third party network provider end offices subtending other BellSouth local tandems in the same local calling area where ComSouth does not choose to establish an interconnection trunk group(s). It is ComSouth's responsibility to enter its own NPA/NXX local tandem homing arrangements into the LERG either directly or via a vendor in order for other third party network providers to determine appropriate traffic routing to ComSouth's codes. Likewise, ComSouth shall obtain its routing information from the LERG.

- 4.10.3.3 Notwithstanding establishing an interconnection trunk group(s) to BellSouth's local tandems, ComSouth must also establish an interconnection trunk group(s) to BellSouth Access Tandems within the LATA on which ComSouth has NPA/NXXs homed for the delivery of Interexchange Carrier Switched Access and toll traffic, and traffic to Type 2A CMRS connections located at the Access Tandems. BellSouth shall not switch SWA traffic through more than one BellSouth access tandem. SWA, Type 2A CMRS or toll traffic routed to the local tandem in error will not be backhauled to the BellSouth Access Tandem for completion. (Type 2A CMRS interconnection is defined in Section A35 of BellSouth's GSST).
- 4.10.3.4 BellSouth's provisioning of Local Tandem Interconnection assumes that ComSouth has executed the necessary local interconnection agreements with the other third party network providers subtending those local tandems as required by the Act.
- 4.10.4 Direct End Office-to-End Office Interconnection
- 4.10.4.1 Direct End Office-to-End Office one-way or two-way interconnection trunk groups allow for the delivery of a Party's originating Local Traffic, ISP-Bound Traffic and IntraLATA Toll Traffic to the terminating Party on a direct end office-to-end office basis.
- 4.10.4.2 The Parties shall utilize direct end office-to-end office trunk groups under any one (1) of the following conditions:
- 4.10.4.2.1 Tandem Exhaust. If a tandem through which the Parties are interconnected is unable to, or is forecasted to be unable to support additional traffic loads for any period of time, the Parties will mutually agree on an end office trunking plan that will alleviate the tandem capacity shortage and ensure completion of traffic between ComSouth and BellSouth.
- 4.10.4.2.2 Traffic Volume. To the extent either Party has the capability to measure the amount of traffic between ComSouth's switch and a BellSouth End Office and where such traffic exceeds or is forecasted to exceed a single DS1 of traffic per month, then the Parties shall install and retain direct end office trunking sufficient to handle such traffic volumes. Either Party will install additional capacity between such points when overflow traffic exceeds or is forecasted to exceed a single DS1 of traffic per month. In the case of one-way trunking, additional trunking shall only be required by the Party whose trunking has achieved the preceding usage threshold.
- 4.10.4.2.3 Mutual Agreement. The Parties may install direct end office trunking upon mutual agreement in the absence of conditions (1) or (2) above.
- 4.10.5 Transit Traffic Trunk Group

- 4.10.5.1 Transit Traffic trunks can either be two-way trunks or two (2) one-way trunks ordered by ComSouth to deliver and receive Transit Traffic. Establishing Transit Traffic trunks at BellSouth Access and Local Tandems provides Intratandem Access to the third parties also interconnected at those tandems. ComSouth shall be responsible for all recurring and nonrecurring charges associated with Transit Traffic trunks and facilities.
- 4.10.5.2 Toll Free Traffic
- 4.10.5.2.1 If ComSouth chooses BellSouth to perform the Service Switching Point (SSP) Function (i.e., handle Toll Free database queries) from BellSouth's switches, all ComSouth originating Toll Free traffic will be routed over the Transit Traffic Trunk Group and shall be delivered using GR-394 format. Carrier Code "0110" and Circuit Code (to be determined for each LATA) shall be used for all such calls.
- 4.10.5.2.2 ComSouth may choose to perform its own Toll Free database queries from its switch. In such cases, ComSouth will determine the nature (local/intraLATA/interLATA) of the Toll Free call (local/IntraLATA/InterLATA) based on the response from the database. If the call is a BellSouth local or intraLATA Toll Free call, ComSouth will route the post-query local or IntraLATA converted ten (10)-digit local number to BellSouth over the local or intraLATA trunk group. If the call is a third party (ICO, IXC, CMRS or other CLEC) local or intraLATA Toll Free call, ComSouth will route the post-query local or intraLATA converted ten (10)-digit local number to BellSouth over the Transit Traffic Trunk Group and ComSouth shall provide to BellSouth a Toll Free billing record when appropriate. If the query reveals the call is an interLATA Toll Free call, ComSouth will route the post-query interLATA Toll Free call (1) directly from its switch for carriers interconnected with its network or (2) over the Transit Traffic Trunk Group to carriers that are not directly connected to ComSouth's network but that are connected to BellSouth's Access Tandem.
- 4.10.5.2.3 All post-query Toll Free calls for which ComSouth performs the SSP function, if delivered to BellSouth, shall be delivered using GR-394 format for calls destined to IXCs, and GR-317 format for calls destined to end offices that directly subtend a BellSouth Access Tandem within the LATA.

5 Network Design And Management For Interconnection

- 5.1 Network Management and Changes. The Parties will exchange toll-free maintenance contact numbers and escalation procedures. The Parties will provide public notice of network changes in accordance with applicable federal and state rules and regulations.
- 5.2 Interconnection Technical Standards. The interconnection of all networks will be based upon accepted industry/national guidelines for transmission standards and traffic blocking criteria. Interconnecting facilities shall conform, at a minimum, to the telecommunications industry standard of DS1 pursuant to Telcordia Standard

No. GR-NWT-00499. Where ComSouth chooses to utilize SS7 signaling, also known as CCS7, SS7 connectivity is required between the ComSouth switch and the BellSouth STP. BellSouth will provide SS7 signaling using Common Channel Signaling Access Capability in accordance with the technical specifications set forth in the BellSouth Guidelines to Technical Publication, GR-905-Core. Facilities of each Party shall provide the necessary on-hook, off-hook answer and disconnect supervision and shall provide calling number ID (Calling Party Number) when technically feasible.

- 5.3 Network Management Controls. Both Parties will work cooperatively to apply sound network management principles by invoking appropriate network management controls (e.g., call gapping) to alleviate or prevent network congestion.

6 Forecasting for Trunk Provisioning

- 6.1 Within six (6) months after execution of this Agreement, ComSouth shall provide an initial interconnection trunk group forecast for each LATA in which it plans to provide service within BellSouth's region. Upon receipt of ComSouth's forecast, the Parties shall conduct a joint planning meeting to develop a joint interconnection trunk group forecast. Each forecast provided under this Section shall be deemed Confidential Information under the General Terms and Conditions.
- 6.1.1 At a minimum, the forecast shall include the projected quantity of Transit Trunks, ComSouth-to-BellSouth one-way trunks (ComSouth Trunks), BellSouth-to-ComSouth one-way trunks (BellSouth Trunk Groups) and/or two-way interconnection trunks, if the Parties have agreed to interconnect using two-way trunking to transport the Parties' Local Traffic, ISP-Bound Traffic and IntraLATA Toll Traffic. The quantities shall be projected for a minimum of six (6) months and shall include an estimate of the current year plus the next two (2) years total forecasted quantities. The Parties shall mutually develop BellSouth Trunk Groups and/or two-way interconnection trunk forecast quantities.
- 6.1.2 All forecasts shall include, at a minimum, Access Carrier Terminal Location (ACTL), trunk group type (e.g., local/intraLATA toll, Transit, Operator Services, 911, etc.), A location/Z location (CLLI codes for ComSouth location and BellSouth location where the trunks shall terminate), interface type (e.g., DS1), Direction of Signaling, Trunk Group Number, if known, (commonly referred to as the 2-6 code) and forecasted trunks in service each year (cumulative).
- 6.2 Once initial interconnection trunk forecasts have been developed, ComSouth shall continue to provide interconnection trunk forecasts at mutually agreeable intervals. ComSouth shall use its best efforts to make the forecasts as accurate as possible based on reasonable engineering criteria. The Parties shall continue to develop Reciprocal Trunk Group and/or two-way interconnection trunk forecasts as described in Section 6.1.1 above.

- 6.3 The submission and development of interconnection trunk forecasts shall not replace the ordering process for local interconnection trunks. Each Party shall exercise its best efforts to provide the quantity of interconnection trunks mutually forecasted. However, the provision of the forecasted quantity of interconnection trunks is subject to trunk terminations and facility capacity existing at the time the trunk order is submitted. Furthermore, the receipt and development of trunk forecasts does not imply any liability for failure to perform if capacity (trunk terminations or facilities) is not available for use at the forecasted time.
- 6.4 Trunk Utilization
- 6.4.1 For the BellSouth Trunk Groups that are Final Trunk Groups (BellSouth Final Trunk Groups), BellSouth and ComSouth shall monitor traffic on each BellSouth Final Trunk Group that is ordered and installed. The Parties agree that the BellSouth Final Trunk Groups will be utilized at sixty percent (60%) of the time consistent busy hour utilization level within ninety (90) days of installation. The Parties agree that the BellSouth Final Trunk Groups will be utilized at eighty percent (80%) of the time consistent busy hour utilization level within one hundred eighty (180) days of installation. Any BellSouth Final Trunk Group not meeting the minimum thresholds set forth in this Section are defined as “under-utilized” trunks. Subject to Section 6.4.2 below, BellSouth may disconnect any under-utilized BellSouth Final Trunk Groups and ComSouth shall refund to BellSouth the associated nonrecurring and recurring trunk and facility charges paid by BellSouth, if any.
- 6.4.2 BellSouth’s CISC will notify ComSouth of any under-utilized BellSouth Trunk Groups and the number of such trunk groups that BellSouth wishes to disconnect. BellSouth will provide supporting information either by email or facsimile to the designated ComSouth interface. ComSouth will provide concurrence with the disconnection in seven (7) business days or will provide specific information supporting why the trunks should not be disconnected. Such supporting information should include expected traffic volumes (including traffic volumes generated due to Local Number Portability) and the timeframes within which ComSouth expects to need such trunks. BellSouth’s CISC Project Manager and Circuit Capacity Manager (CCM) will discuss the information with ComSouth to determine if agreement can be reached on the number of BellSouth Final Trunk Groups to be removed. If no agreement can be reached, BellSouth will issue disconnect orders to ComSouth. The due date of these orders will be four (4) weeks after ComSouth was first notified in writing of the underutilization of the trunk groups.
- 6.4.3 To the extent that any interconnection trunk group is utilized at a time-consistent busy hour of eighty percent (80%) or greater, the Parties may review the trunk groups and, if necessary, shall negotiate in good faith for the installation of augmented facilities.

- 6.4.4 For the two-way trunk groups, BellSouth and ComSouth shall monitor traffic on each interconnection trunk group that is ordered and installed. The Parties agree that within ninety (90) days of the installation of the BellSouth two-way trunk or trunks, the trunks will be utilized at 60 percent (60%) of the time consistent busy hour utilization level. The Parties agree that within one hundred eighty (180) days of the installation of a trunk or trunks, the trunks will be utilized at eighty percent (80%) of the time consistent busy hour utilization level. Any trunk or trunks not meeting the minimum thresholds set forth in this Section are defined as “under-utilized” trunks. BellSouth will request the disconnection of any under-utilized two-way trunk(s) and ComSouth shall refund to BellSouth the associated nonrecurring and recurring trunk and facility charges paid by BellSouth, if any.
- 6.4.4.1 BellSouth’s CISC will notify ComSouth of any under-utilized two-way trunk groups and the number of trunks that BellSouth wishes to disconnect. BellSouth will provide supporting information either by email or facsimile to the designated ComSouth interface. ComSouth will provide concurrence with the disconnection in seven (7) business days or will provide specific information supporting why the two-way trunks should not be disconnected. Such supporting information should include expected traffic volumes (including traffic volumes generated due to Local Number Portability) and the timeframes within which ComSouth expects to need such trunks. BellSouth’s CISC Project Manager and CCM will discuss the information with ComSouth to determine if agreement can be reached on the number of trunks to be removed. If no agreement can be reached, ComSouth will issue disconnect orders to BellSouth. The due date of these orders will be four (4) weeks after ComSouth was first notified in writing of the under-utilization of the trunk groups.
- 6.4.4.2 To the extent that any interconnection trunk group is utilized at a time-consistent busy hour of eighty percent (80%) or greater, the Parties may review the trunk groups and, if necessary, shall negotiate in good faith for the installation of augmented facilities.

7 Local Dialing Parity

- 7.1 BellSouth and ComSouth shall provide local and toll dialing parity, as defined in FCC rules and regulations, with no unreasonable dialing delays. Dialing parity shall be provided for all originating Telecommunications Services that require dialing to route a call.

8 Interconnection Compensation

- 8.1 Compensation for Call Transport and Termination for Local Traffic, ISP-Bound Traffic and IntraLATA Toll Traffic

- 8.1.1 For the purposes of this Attachment and for intercarrier compensation for Local Traffic exchanged between the Parties pursuant to this Attachment, Local Traffic is defined as any telephone call that originates from one Party’s customer located

in one exchange and terminates to the other Party's customer in either the same exchange, or other local calling area associated with the originating calling party's exchange as defined and specified in Section A3 of BellSouth's GSST.

- 8.1.1.1 Additionally, Local Traffic includes any cross boundary, voice-to-voice intrastate, interLATA or interstate, interLATA calls established as a local call by the ruling regulatory body.
- 8.1.2 For purposes of this Attachment and for intercarrier compensation for ISP-Bound Traffic exchanged between the Parties, ISP-Bound Traffic is defined as calls to an information service provider or Internet Service Provider (ISP) that are dialed by using a local dialing pattern (seven (7) or ten (10) digits) by a calling party in one (1) exchange to an ISP server or modem in either the same exchange or other local calling area associated with the originating exchange as defined and specified in Section A3 of BellSouth's GSST. ISP-Bound Traffic is not Local Traffic subject to reciprocal compensation, but instead is information access traffic subject to the FCC's jurisdiction.
- 8.1.3 Neither Party shall pay compensation to the other Party for per minute of use rate elements as set forth in Exhibit A associated with the Call Transport and Termination of Local Traffic or ISP-Bound Traffic.
- 8.1.4 The appropriate elemental rates set forth in Exhibit A shall apply for Transit Traffic as described in this Attachment and for MTA as described in this Attachment.
- 8.1.5 Neither Party shall represent Switched Access Traffic as Local Traffic or ISP-Bound Traffic for purposes of determining compensation for the call.
- 8.1.6 IntraLATA Toll Traffic is defined as all traffic, regardless of transport protocol method, that originates and terminates within a single LATA that is not Local Traffic or ISP-Bound traffic under this Attachment.
- 8.1.6.1 For terminating its intraLATA toll traffic on the other Party's network, the originating Party will pay the terminating Party BellSouth's current intrastate or interstate, whichever is appropriate, terminating switched access tariff rates as set forth in BellSouth's intrastate Access Services Tariffs and/or BellSouth's FCC No. 1 Tariff as filed and in effect with the FCC or appropriate Commission. The appropriate charges will be determined by the routing of the call. Additionally, if one (1) Party is the other Party's customer's presubscribed interexchange carrier or if one (1) Party's customer uses the other Party as an interexchange carrier on a 101XXXX basis, the originating party will charge the other Party the appropriate BellSouth originating switched access tariff rates as set forth in BellSouth's intrastate Access Services Tariff and/or BellSouth's FCC No. 1 Tariff as filed and in effect with the FCC or appropriate Commission.

- 8.1.7 If ComSouth assigns NPA/NXXs to specific BellSouth rate centers within the LATA and assigns numbers from those NPA/NXXs to ComSouth customer physically located outside of that LATA, BellSouth traffic originating from within the LATA where the NPA/NXXs are assigned and delivered to a ComSouth customer physically located outside of such LATA, shall not be deemed Local Traffic. Further, ComSouth agrees to identify such interLATA traffic to BellSouth and to compensate BellSouth for originating and transporting such interLATA traffic to ComSouth at BellSouth's FCC No. 1 Tariff rates.
- 8.2 If ComSouth does not identify such interLATA traffic to BellSouth, BellSouth will determine which whole ComSouth NPA/NXXs on which to charge the applicable rates for originating network access service as reflected in BellSouth's intrastate Access Services Tariff and/or BellSouth's FCC No. 1 Tariff.. BellSouth shall make appropriate billing adjustments if ComSouth can provide sufficient information for BellSouth to determine whether or not said traffic is Local or ISP-Bound Traffic.
- 8.3 Jurisdictional Reporting
- 8.3.1 Percent Local Use (PLU). Each Party shall report to the other a PLU factor. The application of the PLU will determine the amount of local or ISP-Bound minutes to be billed to the other Party. Each Party shall update its PLU on the first of January, April, July and October of the year and shall send it to the other Party to be received no later than thirty (30) days after the first of each such month based on local and ISP-Bound usage for the past three (3) months ending the last day of December, March, June and September, respectively. Requirements associated with PLU calculation and reporting shall be as set forth in BellSouth's Jurisdictional Factors Reporting Guide.
- 8.3.2 Percent Local Facility (PLF). Each Party shall report to the other a PLF factor. The application of the PLF will determine the portion of switched dedicated transport to be billed per the local jurisdiction rates. The PLF shall be applied to Multiplexing, Local Channel and Interoffice Channel Switched Dedicated Transport utilized in the provision of local interconnection trunks. Each Party shall update its PLF on the first of January, April, July and October of the year and shall send it to the other Party to be received no later than thirty (30) days after the first of each such month to be effective the first bill period the following month, respectively. Requirements associated with PLF calculation and reporting shall be as set forth in BellSouth's Jurisdictional Factors Reporting Guide.
- 8.3.3 Percent Interstate Usage (PIU). Each Party shall report to the other the projected PIU factors, including but not limited to PIU associated with facilities (PIUE) and Terminating PIU (TPIU) factors. All jurisdictional report requirements, rules and regulations for Interexchange Carriers specified in BellSouth's intrastate Access Services Tariff will apply to ComSouth. After interstate and intrastate traffic percentages have been determined by use of PIU procedures, the PLU and PLF

factors will be used for application and billing of local interconnection. Each Party shall update its PIUs on the first of January, April, July and October of the year and shall send it to the other Party to be received no later than thirty (30) days after the first of each such month, for all services showing the percentages of use for the past three (3) months ending the last day of December, March, June and September. Additional requirements associated with PIU calculations and reporting shall be as set forth in BellSouth's Jurisdictional Factors Reporting Guide.

- 8.3.4 Notwithstanding the provisions in Sections 8.3.1, 8.3.2, and 8.3.3 above, where BellSouth has message recording technology that identifies the jurisdiction of traffic terminated as defined in this Agreement, such information shall, at BellSouth's option, be utilized to determine the appropriate jurisdictional reporting factors (i.e., PLU, PIU, and/or PLF), in lieu of those provided by ComSouth. In the event that BellSouth opts to utilize its own data to determine jurisdictional reporting factors, BellSouth shall notify ComSouth at least fifteen (15) days prior to the beginning of the calendar quarter in which BellSouth will begin to utilize its own data.
- 8.3.5 ComSouth agrees not to deliver switched access traffic to BellSouth for termination except over ComSouth ordered switched access trunks and facilities. If ComSouth delivers Switched Access Traffic to BellSouth for termination in violation of this Section, BellSouth shall charge ComSouth terminating switched access charges as set forth in BellSouth's Intrastate Access Services Tariff and/or BellSouth's FCC No. 1 Tariff, as appropriate. Additionally, such delivery of traffic shall constitute improper use of BellSouth facilities as set forth in Section 1.5.2 of Attachment 7 of this Agreement.
- 8.3.6 Audits. On thirty (30) days written notice, ComSouth must provide BellSouth the ability and opportunity to conduct an annual audit to ensure the proper billing of traffic. ComSouth shall retain records of call detail for a minimum of nine (9) months from which the PLU, PLF and/or PIU can be ascertained. The audit shall be conducted during normal business hours at an office designated by ComSouth. Audit requests shall not be submitted more frequently than one (1) time per calendar year. Audits shall be performed by an independent auditor chosen by BellSouth. The audited factor (PLF, PLU and/or PIU) shall be adjusted based upon the audit results and shall apply to the usage for the audited period through the time period when the audit is completed, to the usage for the quarter prior to the audit period, and to the usage for the two (2) quarters following the completion of the audit. If, as a result of an audit, ComSouth is found to have overstated the PLF, PLU and/or PIU by twenty percentage points (20%) or more, ComSouth shall reimburse BellSouth for the cost of the audit.
- 8.4 Compensation for IntraLATA 8XX Traffic. ComSouth shall pay the appropriate switched access charges set forth in the BellSouth's intrastate Access Services tariff and/or BellSouth's FCC No. 1 Tariff. ComSouth will pay BellSouth the

database query charge as set forth in the applicable BellSouth intrastate Access Services Tariff and/or BellSouth's FCC No. 1 Tariff. ComSouth will be responsible for any applicable Common Channel Signaling (SS7) charges.

- 8.4.1 Records for 8XX Billing. Where technically feasible, each Party will provide to the other Party the appropriate records, in accordance with industry standards, necessary for billing intraLATA 8XX providers. The records provided will be in a standard EMI format.
- 8.4.2 8XX Toll Free Dialing Ten Digit Screening Service (8XX TFD). BellSouth's provision of 8XX TFD to ComSouth requires interconnection from ComSouth to BellSouth's 8XX Signal Channel Point. Such interconnections shall be established pursuant to BellSouth's Common Channel Signaling Interconnection Guidelines and Telcordia's CCS Network Interface Specification document, TR-TSV-000905. ComSouth shall establish SS7 interconnection at the BellSouth LSTPs serving the BellSouth 8XX Signal Channel Points that ComSouth desires to query. The terms and conditions for 8XX TFD are set out in the appropriate BellSouth Access Services Tariff.
- 8.5 Mutual Provision of Switched Access Service
- 8.5.1 Switched Access Traffic. Switched Access Traffic is described as telephone calls requiring local transmission or switching services for the purpose of the origination or termination of Telephone Toll Service. Switched Access Traffic includes, but is not limited to, the following types of traffic: Feature Group A, Feature Group B, Feature Group C, Feature Group D, toll free access (e.g., 8XX), 900 access and their successors. Additionally, any PSTN interexchange telecommunications traffic, regardless of transport protocol method, where the originating and terminating points, end-to-end points, are in different LATAs, or are in the same LATA and the Parties' Switched Access services are used for the origination or termination of the call, shall be considered Switched Access Traffic. Irrespective of transport protocol method or method of originating or terminating the call, a call that originates in one LATA and terminates in another LATA (i.e., the end-to-end points of the call) or a call in which the Parties' Switched Access Services are used for the origination or termination of the call, shall be considered Switched Access Traffic.
- 8.5.2 If a BellSouth end user chooses ComSouth as their presubscribed interexchange carrier, or if a BellSouth end user uses ComSouth as an interexchange carrier on a 101XXXX basis, BellSouth will charge ComSouth the appropriate BellSouth tariff charges for originating switched access services.
- 8.5.3 Where the originating Party delivers a call to the terminating Party over switched access facilities, the originating Party will pay the terminating Party terminating, switched access charges as set forth in BellSouth's intrastate Access Services Tariff and/or BellSouth's FCC No. 1 Tariff, as appropriate.

- 8.5.4 When ComSouth's end office switch provides an access service connection to or from an IXC by a direct trunk group to the IXC utilizing BellSouth facilities, each Party will provide its own access services to the IXC and bill on a multi-bill, multi-tariff meet-point basis. Each Party will bill its own access services rates to the IXC with the exception of the interconnection charge. The interconnection charge will be billed by ComSouth as the Party providing the end office function. Each party will use the Multiple Exchange Carrier Access Billing (MECAB) guidelines to establish Meet Point Billing for all applicable traffic. The Parties shall utilize a thirty (30) day billing period.
- 8.5.4.1 In cases where ComSouth has a unique hosted Revenue Accounting Office (RAO) code and ComSouth's end office subtends the BellSouth Access Tandem switch for receipt or delivery of switched access traffic and provides an access service connection to or from an IXC via BellSouth's Access Tandem switch, BellSouth, as the tandem company agrees to provide to ComSouth, as the End Office Company, as defined in MECAB, at no charge, all the switched access detail usage data, recorded at the access tandem, within no more than sixty (60) days after the recording date. Each Party will notify the other when it is not feasible to meet these requirements. As business requirements change, data reporting requirements may be modified as necessary.
- 8.5.5 BellSouth, as the tandem provider company, will retain for a minimum period of sixty (60) days, access message detail sufficient to recreate any data that is lost or damaged by the tandem provider company or any third party involved in processing or transporting data.
- 8.6 Transit Traffic
- 8.6.1 BellSouth shall provide tandem switching and transport services for ComSouth's Transit Traffic. Rates for local Transit Traffic and ISP-Bound Transit Traffic shall be the applicable rate elements for Tandem Switching, Common Transport and Tandem Intermediary Charge as set forth in Exhibit A. Rates for Switched Access Transit Traffic shall be the applicable charges as set forth in BellSouth's intrastate Access Services Tariff and/or BellSouth's FCC No. 1 Tariff. Billing associated with all Transit Traffic shall be pursuant to MECAB guidelines. Traffic between ComSouth and Wireless Type 1 third parties or Wireless Type 2A third parties that do not engage in Meet Point Billing with BellSouth shall not be treated as Transit Traffic from a routing or billing perspective until such time as such traffic is identifiable as Transit Traffic.
- 8.6.2 The delivery of traffic that transits the BellSouth network is excluded from any BellSouth billing guarantees. BellSouth agrees to deliver Transit Traffic to the terminating carrier; provided, however, that ComSouth is solely responsible for negotiating and executing any appropriate contractual agreements with the terminating carrier for the exchange of Transit Traffic through the BellSouth network. BellSouth will not be liable for any compensation to the terminating

carrier or to ComSouth. In the event that the terminating third party carrier imposes on BellSouth any charges or costs for the delivery of Transit Traffic, ComSouth shall reimburse BellSouth for such charges or costs.

8.7 For purposes of intercarrier compensation, BellSouth will not be responsible for any compensation associated with the exchange of traffic between ComSouth and a CLEC utilizing BellSouth switching. Where technically feasible, BellSouth will use commercially reasonable efforts to provide records to ComSouth to identify those CLECs utilizing BellSouth switching with whom ComSouth has exchanged traffic. Such traffic shall not be considered Transit Traffic from a routing or billing perspective, but instead will be considered as traffic exchanged solely between ComSouth and the CLEC utilizing BellSouth switching.

8.7.1 ComSouth is solely responsible for negotiating and executing any appropriate contractual agreements with the terminating carrier for the exchange of traffic with a CLEC utilizing BellSouth switching. BellSouth will not be liable for any compensation to the terminating carrier or to ComSouth. In the event that the terminating third party carrier imposes on BellSouth any charges or costs for the delivery of such traffic, ComSouth shall reimburse BellSouth for all such charges or costs.

8.8 ComSouth shall send all IntraLATA toll traffic to be terminated by an independent telephone company to the End User's IntraLATA toll provider and shall not send such traffic to BellSouth as Transit Traffic. IntraLATA toll traffic shall be any traffic that originates outside of the terminating independent telephone company's local calling area.

9 Ordering Charges

9.1 The facilities purchased pursuant to this Attachment shall be ordered via the ASR process.

9.2 The rates, terms and conditions associated with submission and processing of ASRs are as set forth in BellSouth's FCC No. 1 Tariff, Section 5.

10 Basic 911 and E911 Interconnection

10.1 Basic 911 and E911 provides a caller access to the applicable emergency service bureau by dialing 911.

10.2 Basic 911 Interconnection. BellSouth will provide to ComSouth a list consisting of each municipality that subscribes to Basic 911 service. The list will also provide, if known, the E911 conversion date for each municipality and, for network routing purposes, a ten (10) digit directory number representing the appropriate emergency answering position for each municipality subscribing to 911. ComSouth will be required to arrange to accept 911 calls from its end users in municipalities that subscribe to Basic 911 service and translate the 911 call to

the appropriate ten (10) digit directory number as stated on the list provided by BellSouth. ComSouth will be required to route that call to the appropriate PSAP. When a municipality converts to E911 service, ComSouth will be required to begin using E911 procedures.

- 10.3 E911 Interconnection. ComSouth shall install a minimum of two (2) dedicated trunks originating from its SWC and terminating to the appropriate E911 tandem. The SWC must be in the same LATA as the E911 tandem. The dedicated trunks shall be, at a minimum, DS0 level trunks configured as part of a digital (one point five forty-four (1.544) Mb/s) interface (DS1 facility). The configuration shall use CAMA-type signaling with MF pulsing or SS7/ISUP signaling either of which shall deliver ANI with the voice portion of the call. If SS7/ISUP connectivity is used, ComSouth shall follow the procedures as set forth in Appendix A of the CLEC Users Guide to E911 for Facility Based Providers that is located on the BellSouth Interconnection Web site. If the user interface is digital, MF pulses as well as other AC signals shall be encoded per the u-255 Law convention. ComSouth will be required to provide BellSouth daily updates to the E911 database. ComSouth will be required to forward 911 calls to the appropriate E911 tandem along with ANI based upon the current E911 end office to tandem homing arrangement as provided by BellSouth. If the E911 tandem trunks are not available, ComSouth will be required to route the call to a designated seven (7) digit or ten (10) digit local number residing in the appropriate PSAP. This call will be transported over BellSouth's interoffice network and will not carry the ANI of the calling party. ComSouth shall be responsible for providing BellSouth with complete and accurate data for submission to the 911/E911 database for the purpose of providing 911/E911 to its end users.
- 10.4 Trunks and facilities for 911 Interconnection may be ordered by ComSouth from BellSouth pursuant to the terms and conditions set forth in this Attachment.
- 10.5 The detailed practices and procedures for 911/E911 interconnection are contained in the E911 Local Exchange Carrier Guide For Facility-Based Providers that is located on the BellSouth Interconnection Services Web site.

11 SS7 Network Interconnection

- 11.1 SS7 Signaling. Both Parties will utilize LEC-to-LEC SS7 Signaling, where available, in conjunction with all traffic in order to enable interoperability of CLASS features and functions except for call return. SS7 signaling parameters will be provided, including but not limited to ANI, originating line information (OLI) calling company category and charge number. Privacy indicators will be honored, and the Parties will exchange Transactional Capabilities Application Part (TCAP) messages to facilitate SS7 based features between the respective networks. Neither Party shall alter the SS7 parameters, or be a party to altering such parameters, or knowingly pass SS7 parameters that have been altered in order to circumvent appropriate interconnection charges. Nothing herein shall obligate

or otherwise require BellSouth to send SS7 messages or call-related database queries to ComSouth's or any other third party's call-related database, unless otherwise agreed to by the Parties under a separate agreement.

- 11.2 Signaling Call Information. BellSouth and ComSouth will send and receive ten (10) digits for Local Traffic. Additionally, BellSouth and ComSouth will exchange the proper call information, (i.e., originated call company number and destination call company number, CIC, and OZZ) including all proper translations for routing between networks and any information necessary for billing.
- 11.3 SS7 Network Interconnection is the interconnection of ComSouth LSTP switches or ComSouth local or tandem switching systems with BellSouth STP switches. This interconnection provides connectivity that enables the exchange of SS7 messages among BellSouth switching systems and databases, ComSouth local or tandem switching systems, and other third party switching systems directly connected to the BellSouth SS7 network.
- 11.3.1 The connectivity provided by SS7 Network Interconnection shall fully support the functions of BellSouth switching systems and databases and ComSouth or other third party switching systems with A-link access to the BellSouth SS7 network.
- 11.3.2 If traffic is routed based on dialed or translated digits between a ComSouth local switching system and a BellSouth or other third party local switching system, either directly or via a BellSouth tandem switching system, then it is a requirement that the BellSouth SS7 network convey via SS7 Network Interconnection the TCAP messages that are necessary to provide Call Management services (i.e., Automatic Callback, Automatic Recall, and Screening List Editing) between the ComSouth LSTP switches and BellSouth or other third party local switch.
- 11.3.3 SS7 Network Interconnection shall provide:
- 11.3.3.1 Signaling Data Link functions, as specified in ANSI T1.111.2;
- 11.3.3.2 Signaling Link functions, as specified in ANSI T1.111.3; and
- 11.3.3.3 Signaling Network Management functions, as specified in ANSI T1.111.4.
- 11.3.4 SS7 Network Interconnection shall provide all functions of the SCCP necessary for Class 0 (basic connectionless) service as specified in ANSI T1.112. This includes GTT and SCCP Management procedures as specified in ANSI T1.112.4. Where the destination signaling point is a BellSouth switching system or DB, or is another third party local or tandem switching system directly connected to the BellSouth SS7 network, SS7 Network Interconnection shall include final GTT of messages to the destination and SCCP Subsystem Management of the destination. Where the destination signaling point is a ComSouth local or tandem switching system, SS7 Network Interconnection shall include intermediate GTT of messages

to a gateway pair of ComSouth LSTPs and shall not include SCCP Subsystem Management of the destination.

- 11.3.5 SS7 Network Interconnection shall provide all functions of the ISUP as specified in ANSI T1.113.
- 11.3.6 SS7 Network Interconnection shall provide all functions of the TCAP as specified in ANSI T1.114.
- 11.3.7 If Internetwork MRVT and SRVT become approved ANSI standards and available capabilities of BellSouth STPs, SS7 Network Interconnection may provide these functions of the OMAP.
- 11.4 Interface Requirements. The following SS7 Network Interconnection interface options are available to connect ComSouth or ComSouth-designated local or tandem switching systems or signaling transfer point switches to the BellSouth SS7 network:
 - 11.4.1 A-link interface from ComSouth local or tandem switching systems; and
 - 11.4.2 B-link interface from ComSouth STPs.
 - 11.4.3 The Signaling Point of Interconnection for each link shall be located at a cross-connect element in the central office where the BellSouth STP is located. There shall be a DS1 or higher rate transport interface at each of the signaling points of interconnection. Each signaling link shall appear as a DS0 channel within the DS1 or higher rate interface.
 - 11.4.4 BellSouth shall provide intraoffice diversity between the Signaling Point of Interconnection and the BellSouth STP, so that no single failure of intraoffice facilities or equipment shall cause the failure of both B-links in a layer connecting to a BellSouth STP.
 - 11.4.5 The protocol interface requirements for SS7 Network Interconnection include the MTP, ISUP, SCCP, and TCAP. These protocol interfaces shall conform to the applicable industry standard technical references.
 - 11.4.6 BellSouth shall set message screening parameters to accept messages from ComSouth local or tandem switching systems destined to any signaling point in the BellSouth SS7 network with which the ComSouth switching system has a valid signaling relationship.
- 11.5 Rates. The Parties shall institute a “bill and keep” compensation plan under which neither Party will charge the other Party recurring and nonrecurring charges as set forth in Exhibit A for CCS7 signaling messages associated with Local Traffic. The portion of CCS7 signaling messages utilized for Local Traffic, which are subject to bill and keep in accordance with this section, shall be determined based upon the

application of the applicable signaling factors set forth in BellSouth's Jurisdictional Factors Reporting Guide. The remaining portion of the CCS7 signaling messages, signaling ports, and signaling links, i.e. the portion associated with interstate calls and with intrastate non-local calls, shall be billed in accordance with the applicable BellSouth intrastate Access Services Tariff and BellSouth's FCC No. 1 Tariff for switched access services.

Basic Architecture

Exhibit B

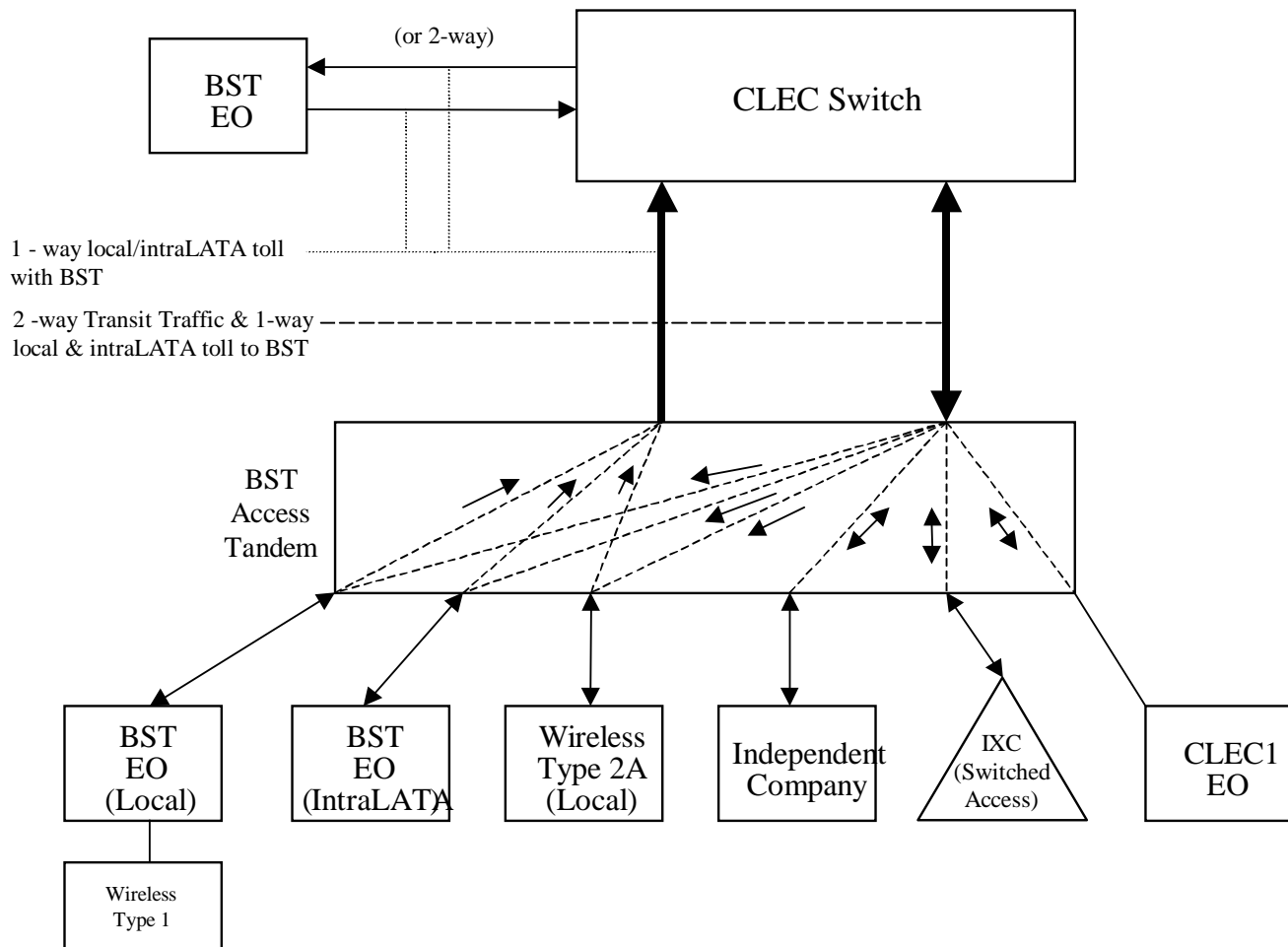

Exhibit C

One-Way Architecture

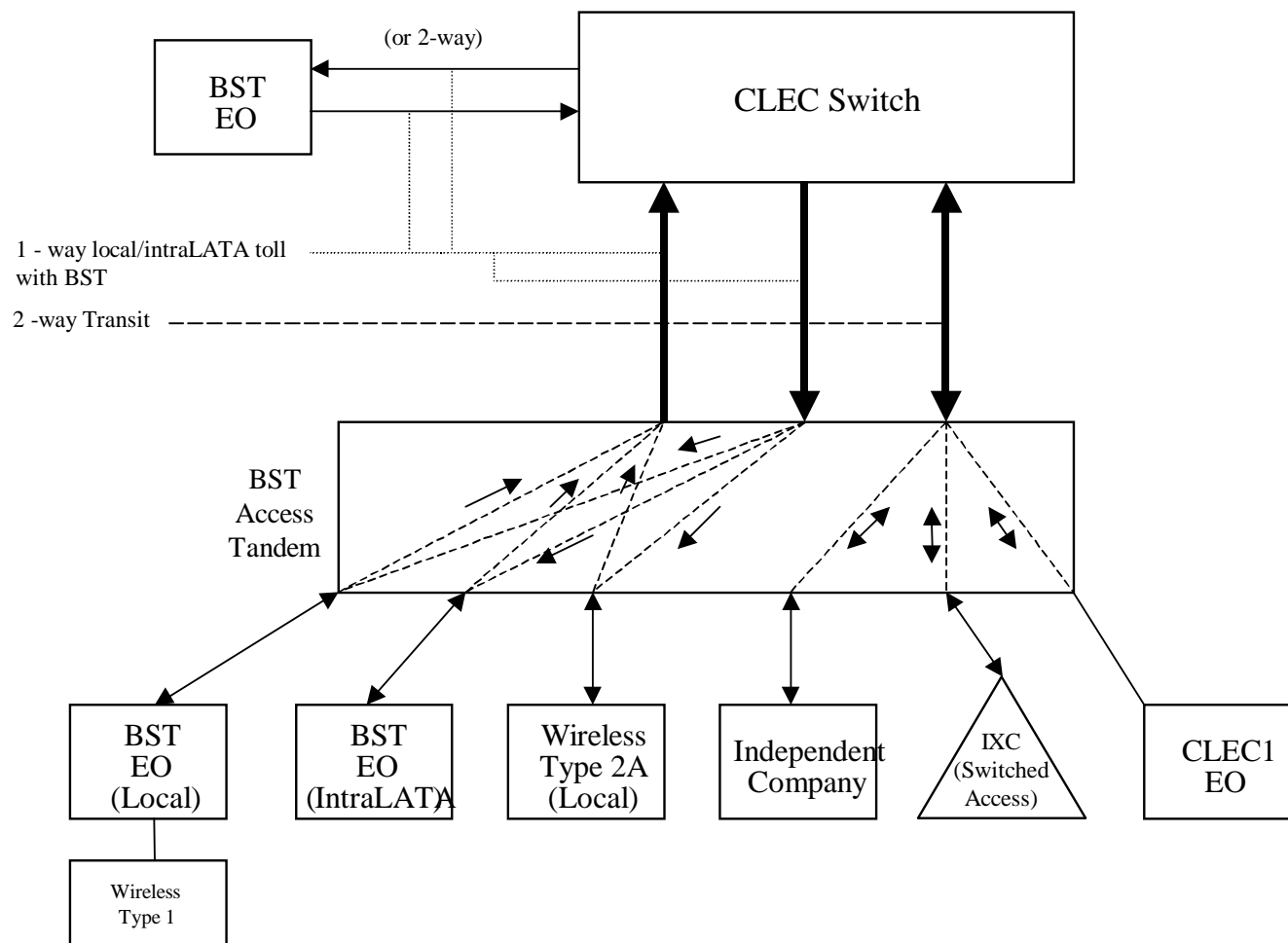

Exhibit D

Two-Way Architecture

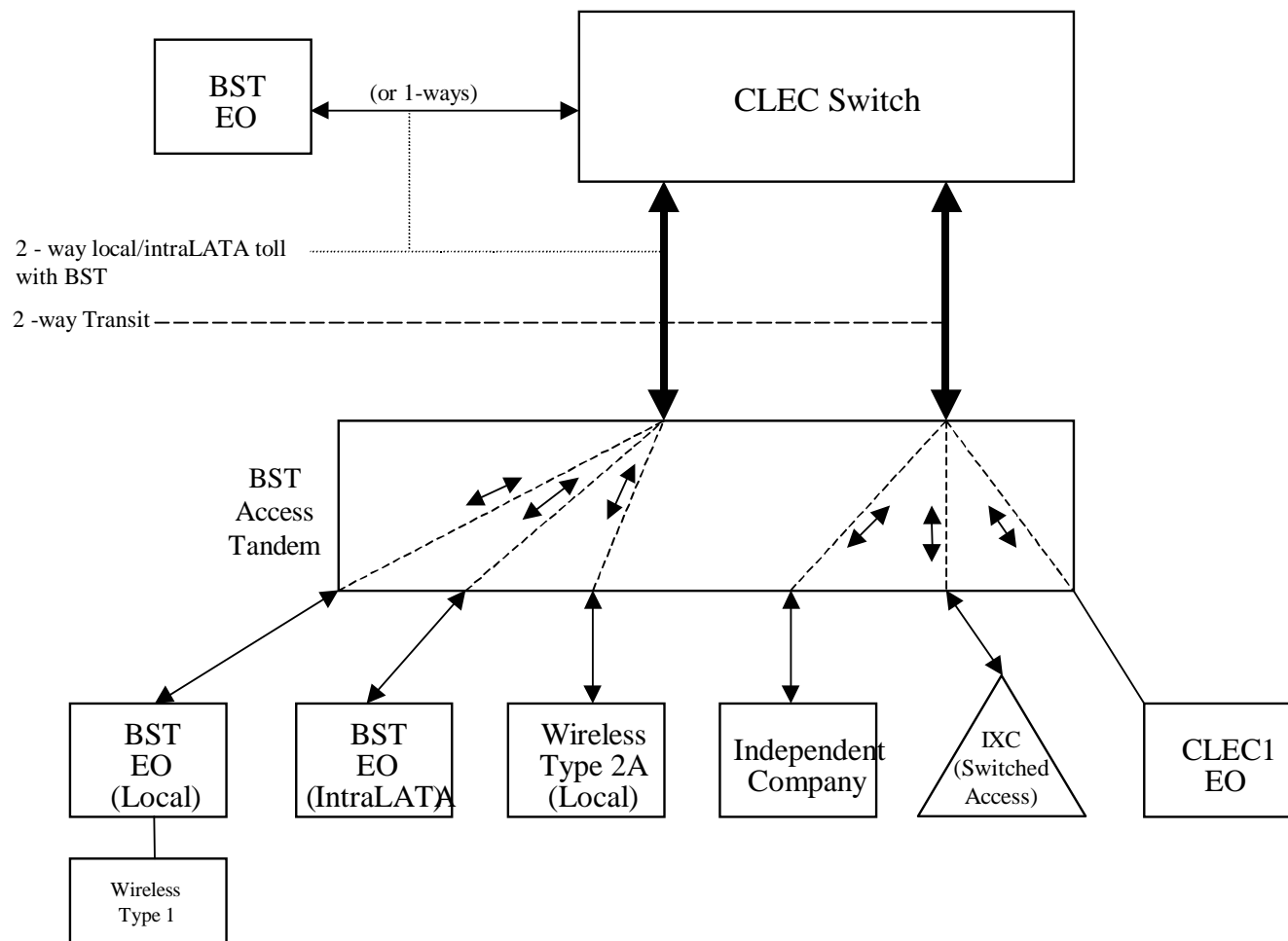
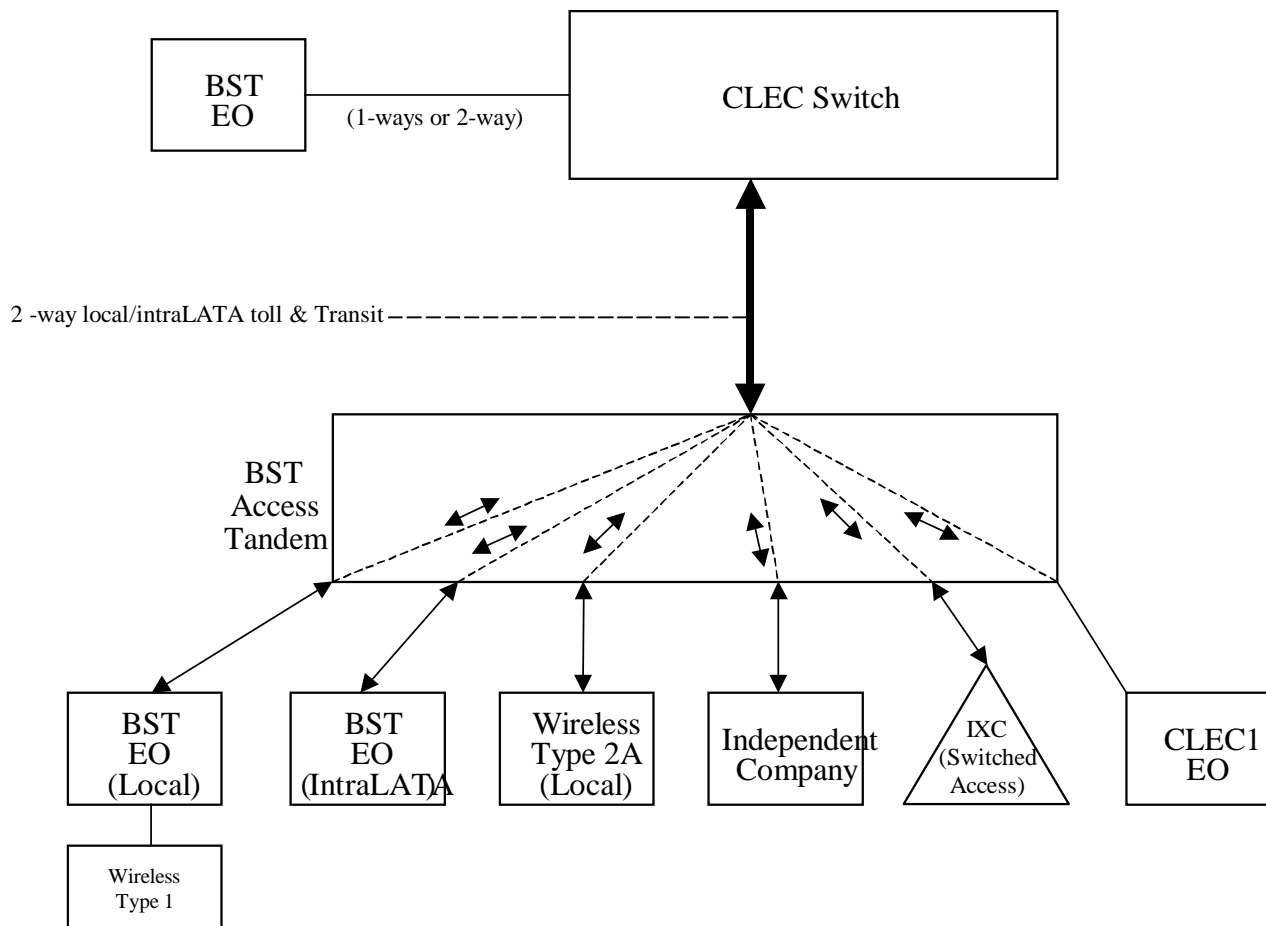

Exhibit E

Supergroup Architecture



LOCAL INTERCONNECTION - Georgia											Att: 3 Exh: A				
CATEGORY	RATE ELEMENTS	Interim	Zone	BCS	USOC	RATES(\$)				Svc Order Submitted Elec per LSR	Svc Order Submitted Manually per LSR	Incremental Charge - Manual Svc Order vs. Electronic-1st	Incremental Charge - Manual Svc Order vs. Electronic-Add'l	Incremental Charge - Manual Svc Order vs. Electronic-Disc 1st	Incremental Charge - Manual Svc Order vs. Electronic-Disc Add'l
						Rec	Nonrecurring		Nonrecurring Disconnect						
						First	Add'l	First	Add'l	SOMEC	SOMAN	SOMAN	SOMAN	SOMAN	SOMAN
LOCAL INTERCONNECTION (CALL TRANSPORT AND TERMINATION)															
NOTE: "bk" beside a rate indicates that the Parties have agreed to bill and keep for that element pursuant to the terms and conditions in Attachment 3.															
TANDEM SWITCHING															
	Tandem Switching Function Per MOU					0.0004186bk									
	Multiple Tandem Switching, per MOU (applies to initial tandem only)					0.0004186									
	Tandem Intermediary Charge, per MOU*					0.0025									
* This charge is applicable only to transit traffic and is applied in addition to applicable switching and/or interconnection charges.															
TRUNK CHARGE															
	Installation Trunk Side Service - per DS0			OHD	TPP6X	21.53	8.11								
	Installation Trunk Side Service - per DS0			OHD	TPP9X	21.53	8.11								
	Dedicated End Office Trunk Port Service-per DS0**			OHD	TDEOP	0.00									
	Dedicated End Office Trunk Port Service-per DS1**			OH1 OH1MS	TDE1P	0.00									
	Dedicated Tandem Trunk Port Service-per DS0**			OHD	TDWOP	0.00									
	Dedicated Tandem Trunk Port Service-per DS1**			OH1 OH1MS	TDW1P	0.00									
** This rate element is recovered on a per MOU basis and is included in the End Office Switching and Tandem Switching, per MOU rate elements															
COMMON TRANSPORT (Shared)															
	Common Transport - Per Mile, Per MOU					0.0000028bk									
	Common Transport - Facilities Termination Per MOU					0.0001955bk									
LOCAL INTERCONNECTION (DEDICATED TRANSPORT)															
INTEROFFICE CHANNEL - DEDICATED TRANSPORT															
	Interoffice Channel - Dedicated Transport - 2-Wire Voice Grade - Per Mile per month			OHM	1L5NF	0.0059									
	Interoffice Channel - Dedicated Transport- 2- Wire Voice Grade - Facility Termination per month			OHM	1L5NF	13.15	48.41	19.46	16.56	4.99					
	Interoffice Channel - Dedicated Transport - 56 kbps - per mile per month			OHM	1L5NK	0.0059									
	Interoffice Channel - Dedicated Transport - 56 kbps - Facility Termination per month			OHM	1L5NK	8.00	48.41	19.46	16.56	4.99					
	Interoffice Channel - Dedicated Transport - 64 kbps - per mile per month			OHM	1L5NK	0.0059									
	Interoffice Channel - Dedicated Transport - 64 kbps - Facility Termination per month			OHM	1L5NK	8.00	48.41	19.46	16.56	4.99					
	Interoffice Channel - Dedicated Channel - DS1 - Per Mile per month			OH1, OH1MS	1L5NL	0.1199									
	Interoffice Channel - Dedicated Transport - DS1 - Facility Termination per month			OH1, OH1MS	1L5NL	34.93	110.92	80.20	31.33	21.71					
	Interoffice Channel - Dedicated Transport - DS3 - Per Mile per month			OH3, OH3MS	1L5NM	2.63									
	Interoffice Channel - Dedicated Transport - DS3 - Facility Termination per month			OH3, OH3MS	1L5NM	349.42	320.16	86.24	66.71	52.76					
LOCAL CHANNEL - DEDICATED TRANSPORT															
	Local Channel - Dedicated - 2-Wire Voice Grade per month			OHM	TEFV2	7.91	120.95	53.24	46.35	13.35					
	Local Channel - Dedicated - 4-Wire Voice Grade per month			OHM	TEFV4	8.90	125.50	54.38	46.35	13.35					
	Local Channel - Dedicated - DS1 per month			OH1	TEFHG	22.82	149.31	111.09	40.32	26.09					
	Local Channel - Dedicated - DS3 Facility Termination per month			OH3	TEFHJ	150.05	444.58	145.04	112.80	75.81					
LOCAL INTERCONNECTION MID-SPAN MEET															
	Local Channel - Dedicated - DS1 per month			OH1MS	TEFHG	0.00	0.00								
	Local Channel - Dedicated - DS3 per month			OH3MS	TEFHJ	0.00	0.00								
MULTIPLEXERS															
	Channelization - DS1 to DS0 Channel System			OH1, OH1MS	SATN1	71.23	105.57	41.545	23.73	4.19					
	DS3 to DS1 Channel System per month			OH3, OH3MS	SATNS	124.39	224.255	71.76	39.965	31.035					
	DS3 Interface Unit (DS1 COC) per month			OH1, OH1MS	SATCO	7.50	15.79	11.375	6.60	6.60					
Notes: If no rate is identified in the contract, the rates, terms, and conditions for the specific service or function will be as set forth in applicable BellSouth tariff.															
SIGNALING (CCS7)															
NOTE: "bk" beside a rate indicates that the parties have agreed to bill and keep for that element pursuant to the terms and conditions in Attachment 3.															
	CCS7 Signaling Connection, Per 56Kbps Facility A-Link DS1			UDB	TPP6A	8.93	34.74	34.74	16.90	16.90					
	CCS7 Signaling Connection, Per 56Kbps Facility A-Link DS3			UDB	TPP9A	8.93	34.74	34.74	16.90	16.90					
	CCS7 Signaling Connection, Per 56Kbps Facility B-Link DS1			UDB	TPP6B	8.93	34.74	34.74	16.90	16.90					
	CCS7 Signaling Connection, Per 56Kbps Facility B-Link DS3			UDB	TPP9B	8.93	34.74	34.74	16.90	16.90					
	CCS7 Signaling Termination, Per STP Port			UDB	PT8SX	111.30									
	CCS7 Signaling Usage, Per Call Setup Message					.0000134bk									

LOCAL INTERCONNECTION - Georgia											Att: 3 Exh: A				
CATEGORY	RATE ELEMENTS	Interim	Zone	BCS	USOC	RATES(\$)				Svc Order Submitted Elec per LSR	Svc Order Submitted Manually per LSR	Incremental Charge - Manual Svc Order vs. Electronic-1st	Incremental Charge - Manual Svc Order vs. Electronic-Add'l	Incremental Charge - Manual Svc Order vs. Electronic-Disc 1st	Incremental Charge - Manual Svc Order vs. Electronic-Disc Add'l
						Rec	Nonrecurring		Nonrecurring Disconnect						
						First	Add'l	First	Add'l	SOME C	SOMAN	SOMAN	SOMAN	SOMAN	SOMAN
	CCS7 Signaling Usage, Per TCAP Message					0.0000536bk									
	CCS7 Signaling Usage, Per ISUP Message (same as E.3.3)					.0000134bk									
	CCS7 Signaling Usage Surrogate, per link			UDB	STU56	921.93bk									
	CCS7 Signaling Point Code, Establishment or Change, per STP affected			UDB	CCAPO		28.12	28.12	33.29	33.29					
	CCS7 Signaling Connection, Switched access service, interface groups, transmission paths 6 DS1 level path with bit stream signaling			UDB	TPP6X	8.93	34.74	34.74	16.90	16.90					
	CCS7 Signaling Connection, Switched access service, interface groups, transmission paths 9 DS3 level path with bit stream signaling			UDB	TPP9X	8.93	34.74	34.74	16.90	16.90					

Attachment 4
BellSouth Collocation

Table of Contents

1. Scope of Attachment 3

2. Optional Reports 6

3. Collocation Options..... 6

4. Occupancy 12

5. Use of Collocation Space 13

6. Ordering and Preparation of Collocation Space..... 21

7. Construction and Provisioning 25

8. Rates and Charges 30

9. Insurance 39

10. Mechanics Lien..... 40

11. Inspections 41

12. Security and Safety Requirements 41

13. Destruction of Collocation Space..... 43

14. Eminent Domain 44

15. Nonexclusivity 44

Environmental & Safety Principles..... Exhibit A

Rates..... Exhibit B

BELLSOUTH COLLOCATION

1. Scope of Attachment

1.1 BellSouth Premises

1.1.1 The rates, terms and conditions contained within this Attachment shall only apply when ComSouth is physically collocated as a sole occupant or as a Host within a BellSouth Premises pursuant to this Attachment. BellSouth Premises, as defined in this Attachment includes BellSouth Central Offices, and Remote Terminals (hereinafter “BellSouth Premises”). This Attachment is applicable to BellSouth Premises owned or leased by BellSouth. Where not specified, the language in this Attachment applies to both Central Office and Remote Site Collocation.

1.1.2 Third Party Property. If the BellSouth Premises, or the property on which it is located, is leased by BellSouth from a third party or otherwise controlled by a third party, special considerations and intervals may apply in addition to the terms and conditions of this Attachment. Additionally, where BellSouth notifies ComSouth that BellSouth’s agreement with a third party does not grant BellSouth the ability to provide access and use rights to others, upon ComSouth’s request, BellSouth will use commercially reasonable efforts to obtain the owner’s consent and to otherwise secure such rights for ComSouth. ComSouth agrees to reimburse BellSouth for all costs incurred by BellSouth in obtaining such rights for ComSouth. In cases where a third party agreement does not grant BellSouth the right to provide access and use rights to others as contemplated by this Attachment and BellSouth, is unable to secure such access and use rights for ComSouth, ComSouth shall be responsible for obtaining such permission to access and use such property. BellSouth shall cooperate with ComSouth in obtaining such permission.

1.2 Right to Occupy

1.2.1 BellSouth shall offer to ComSouth collocation on rates, terms and conditions that are just, reasonable, nondiscriminatory and consistent with the rules of the FCC. Subject to the rates, terms and conditions of this Attachment, where space is available and it is technically feasible, BellSouth will allow ComSouth to occupy a certain area designated by BellSouth within a BellSouth Premises, or on BellSouth property upon which the BellSouth Premises is located, of a size which is specified by ComSouth and agreed to by BellSouth (hereinafter “Collocation Space”). Except as otherwise specified, any references to Collocation Space shall be for physical collocation. The necessary rates, terms and conditions for a premises as defined by the FCC, other than BellSouth Premises, shall be negotiated upon reasonable request for collocation at such premises.

1.2.2 Neither BellSouth nor any of BellSouth’s affiliates may reserve space for future use on more preferential terms than those set forth in this Attachment.

1.2.2.1 The size specified by ComSouth may contemplate a request for space sufficient to accommodate ComSouth’s growth within a twenty-four (24) month period.

- 1.3 Space Allocation. BellSouth shall assign ComSouth Collocation Space that utilizes existing infrastructure (e.g., heating, ventilation, air conditioning (HVAC), lighting and available power), if such space is available for collocation. Otherwise, BellSouth shall attempt to accommodate ComSouth's requested space preferences, if any, including the provision of contiguous space for any subsequent request for collocation. In allocating Collocation Space, BellSouth shall not materially increase ComSouth's cost or materially delay ComSouth's occupation and use of the Collocation Space, assign Collocation Space that will impair the quality of service or otherwise limit the service ComSouth wishes to offer, reduce unreasonably the total space available for physical collocation or preclude reasonable physical collocation within the BellSouth Premises. Space shall not be available for collocation if it is: (a) physically occupied by non-obsolete equipment; (b) assigned to another collocated telecommunications carrier; (c) used to provide physical access to occupied space; (d) used to enable technicians to work on equipment located within occupied space; (e) properly reserved for future use, either by BellSouth or another collocated telecommunications carrier; or (f) essential for the administration and proper functioning of the BellSouth Premises. BellSouth may segregate Collocation Space and require separate entrances for collocated telecommunications carriers to access their Collocation Space, pursuant to FCC Rules.
- 1.4 Transfer of Collocation Space
- 1.4.1 ComSouth shall be allowed to transfer Collocation Space to another CLEC under the following conditions: (1) the BellSouth Premises is not at or near space exhaustion; (2) the transfer of space shall be contingent upon BellSouth's approval, which will not be unreasonably withheld; (3) ComSouth has no unpaid, undisputed collocation charges; and (4) the transfer of the Collocation Space is in conjunction with ComSouth's sale of all or substantially all, of the in-place collocation equipment to the same CLEC.
- 1.4.2 The responsibilities of ComSouth shall include: (1) submitting a letter of authorization to BellSouth for the transfer; (2) entering into a transfer agreement with BellSouth and the acquiring CLEC; and (3) returning all Security Access Devices to BellSouth. The responsibilities of the acquiring CLEC shall include: (1) submitting an application to BellSouth for the transfer of the Collocation Space; (2) satisfying all requirements of its interconnection agreement with BellSouth; (3) submitting a letter to BellSouth for the assumption of services; and (4) entering into a transfer agreement with BellSouth and ComSouth.
- 1.4.3 In conjunction with a transfer of Collocation Space, any services associated with the Collocation Space shall be transferred pursuant to separately negotiated rates, terms and conditions.
- 1.5 Space Reclamation
- 1.5.1 In the event of space exhaust within a BellSouth Premises, BellSouth may include in its documentation for the Petition for Waiver filed with the Commission, any unutilized space in the BellSouth Premises. ComSouth will be responsible for the

justification of unutilized space within its Collocation Space, if the Commission requires such justification.

- 1.5.2 BellSouth may reclaim unused Collocation Space when a BellSouth Premises is at, or near, space exhaustion and ComSouth cannot demonstrate that ComSouth will utilize the Collocation Space in the time frames set forth below in Section 1.5.3. In the event of space exhaust or near exhaust within a BellSouth Premises, BellSouth will provide written notice to ComSouth requesting that ComSouth release non-utilized Collocation Space to BellSouth, when one hundred percent (100%) of the Collocation Space in ComSouth's collocation arrangement is not being utilized.
- 1.5.3 Within twenty (20) days of receipt of written notification from BellSouth, ComSouth shall either: (1) return the non-utilized Collocation Space to BellSouth in which case ComSouth shall be relieved of all obligations for charges associated with that portion of the Collocation Space applicable from the date the Collocation Space is returned to BellSouth; or (2) for all states provide BellSouth with information demonstrating that the Collocation Space will be utilized within twenty-four (24) months from the date ComSouth accepted the Collocation Space (Acceptance Date) from BellSouth.
- 1.5.4 Disputes concerning BellSouth's claim of space exhaust, or near exhaust, or ComSouth's refusal to return requested Collocation Space should be resolved by BellSouth and ComSouth pursuant to the dispute resolution language contained in the General Terms and Conditions.
- 1.6 Use of Space. ComSouth may only place in the Collocation Space equipment necessary for interconnection with BellSouth's services/facilities or for accessing BellSouth's unbundled network elements for the provision of Telecommunications Services, as specifically set forth in this Agreement. The Collocation Space assigned to ComSouth may not be used for any purposes other than as specifically described herein, including, but not limited to office space or a place of reporting for ComSouth's employees or certified suppliers.
- 1.7 Rates and Charges. ComSouth agrees to pay the rates and charges identified in Exhibit B.
- 1.8 Due Dates. If any due date contained in this Attachment falls on a weekend or a national holiday, then the due date will be the next business day thereafter. For intervals of ten (10) days or less, national holidays will be excluded. For purposes of this Attachment, national holidays include the following: New Year's Day, Martin Luther King, Jr. Day, President's Day (Washington's Birthday), Memorial Day, Independence Day, Labor Day, Columbus Day, Veteran's Day, Thanksgiving Day and Christmas Day.
- 1.9 Compliance. Subject to Section 24 of the General Terms and Conditions of this Agreement, the Parties agree to comply with all applicable federal, state, county, local and administrative laws, rules, ordinances, regulations and codes in the

performance of their obligations hereunder.

2 Optional Reports

2.1 Space Availability Report. Upon request from ComSouth and at ComSouth's expense, BellSouth will provide a written report (Space Availability Report) describing in detail the space that is currently available for collocation at a particular BellSouth Premises. This report will include the amount of Collocation Space available at the BellSouth Premises requested, the number of collocators present at the BellSouth Premises, any modifications in the use of the space since the last report on the BellSouth Premises requested and the measures BellSouth is taking to make additional space available for collocation arrangements. A Space Availability Report does not reserve space at the BellSouth Premises for which the Space Availability Report was requested by ComSouth.

2.1.1 The request from ComSouth for a Space Availability Report must be in writing and include the BellSouth Premises street address, as identified in the LERG, and the CLLI code for the BellSouth Premises requested. CLLI code information is located in the NECA Tariff FCC No. 4.

2.1.2 BellSouth will respond to a request for a Space Availability Report for a particular BellSouth Premises within ten (10) days of the receipt of such request.

2.1.3 BellSouth will use commercially reasonable efforts to respond in ten (10) days to a Space Availability Report request when the request includes from two (2) to five (5) BellSouth Premises within the same state. The response time for Space Availability Report requests of more than five (5) BellSouth Premises, whether the request is for the same state or for two (2) or more states within the BellSouth Region, shall be negotiated between the Parties.

2.2 Remote Terminal Information. Upon request, BellSouth will provide ComSouth with the following information concerning BellSouth's remote terminals: (i) the address of the remote terminal; (ii) the CLLI code of the remote terminal; (iii) the carrier serving area of the remote terminal; (iv) the designation of which remote terminals subtend a particular central office; and (v) the number and address of customers that are served by a particular remote terminal.

2.2.1 BellSouth will provide this information within thirty (30) days of a ComSouth request subject to the following conditions: (i) the information will only be provided on a CD in the same format in which it appears in BellSouth's systems; and (ii) the information will only be provided for each serving wire center designated by ComSouth, up to a maximum of thirty (30) wire centers per ComSouth request per month per state. BellSouth will bill the nonrecurring charge pursuant to the rates in Exhibit B at the time BellSouth sends the CD.

3 Collocation Options

3.1 Cageless Collocation. BellSouth shall allow ComSouth to collocate ComSouth's equipment and facilities without requiring the construction of a cage or similar structure. BellSouth shall allow ComSouth to have direct access to ComSouth's equipment and facilities in accordance with Section 5.1.2 below. BellSouth shall

make cageless collocation available in single bay increments. Except where ComSouth's equipment requires special technical considerations (e.g., special cable racking or isolated ground plane), BellSouth shall assign cageless Collocation Space in conventional equipment rack lineups where feasible. For equipment requiring special technical considerations, ComSouth must provide the equipment layout, including spatial dimensions for such equipment pursuant to generic requirements contained in Telcordia GR-63-Core, and shall be responsible for compliance with all special technical requirements associated with such equipment.

3.2 Caged Collocation

3.2.1 BellSouth will make caged Collocation Space in Central Offices available in fifty (50) square foot increments. At ComSouth's option and expense, ComSouth will arrange with a Supplier certified by BellSouth (BellSouth Certified Supplier) to construct a collocation arrangement enclosure in accordance with BellSouth's specifications for a wire mesh enclosure prior to starting equipment installation. Where local building codes require enclosure specifications more stringent than BellSouth's wire mesh enclosure specifications, ComSouth and ComSouth's BellSouth Certified Supplier must comply with the more stringent local building code requirements. ComSouth's BellSouth Certified Supplier shall be responsible for filing and obtaining any and all necessary permits and/or licenses for such construction. BellSouth or BellSouth's designated agent or contractor shall provide, at ComSouth's expense, documentation, which may include existing building architectural drawings, enclosure drawings, specifications, etc., necessary for ComSouth's BellSouth Certified Supplier to obtain all necessary permits and/or other licenses. ComSouth's BellSouth Certified Supplier shall bill ComSouth directly for all work performed for ComSouth. BellSouth shall have no liability for, nor responsibility to pay, such charges imposed by ComSouth's BellSouth Certified Supplier. ComSouth must provide the local BellSouth Central Office Building Contact with two (2) Access Keys that will allow entry into the locked enclosure. Except in the case of an emergency, BellSouth will not access ComSouth's locked enclosure prior to notifying ComSouth at least forty-eight (48) hours or two (2) business days, whichever is greater, before access to ComSouth's Collocation Space is required. Upon request, BellSouth shall construct the enclosure for ComSouth.

3.2.2 In the event ComSouth's BellSouth Certified Supplier will construct the collocation arrangement enclosure, BellSouth may elect to review ComSouth's plans and specifications, prior to allowing the construction to start, to ensure compliance with BellSouth's wire mesh enclosure specifications. BellSouth will notify ComSouth of its desire to conduct this review in BellSouth's Application Response, as defined herein, to ComSouth's Initial Application. If ComSouth's Initial Application does not indicate its desire to construct its own enclosure and ComSouth subsequently decides to construct its own enclosure prior to BellSouth's Application Response, then ComSouth will resubmit its Initial Application, indicating its desire to construct its own enclosure. If ComSouth

subsequently decides construct its own enclosure after the bona fide firm order (hereinafter “BFFO”) has been accepted by BellSouth, ComSouth will submit a Subsequent Application, as defined in Section 6.2 below. If BellSouth elects to review ComSouth’s plans and specifications, then BellSouth will provide notification to ComSouth within ten (10) days after the Initial Application BFFO date or, if a Subsequent Application is submitted as set forth in the preceding sentence, then the Subsequent Application BFFO date. BellSouth shall complete its review within fifteen (15) days after BellSouth’s receipt of ComSouth’s plans and specifications. Regardless of whether or not BellSouth elects to review ComSouth’s plans and specifications, BellSouth reserves the right to inspect the enclosure after construction has been completed to ensure that it is constructed according to ComSouth’s submitted plans and specifications and/or BellSouth’s wire mesh enclosure specifications, as applicable. If BellSouth decides to inspect the constructed Collocation Space, BellSouth will complete its inspection within fifteen (15) days after receipt of ComSouth’s written notification that the enclosure has been completed. Within seven (7) days after BellSouth has completed its inspection of ComSouth’s caged Collocation Space, BellSouth shall require ComSouth, at ComSouth’s expense, to remove or correct any structure that does not meet ComSouth’s plans and specifications or BellSouth’s wire mesh enclosure specifications, as applicable.

3.3 Shared Caged Collocation

3.3.1 ComSouth may allow other telecommunications carriers to share ComSouth’s caged Collocation Space, pursuant to the terms and conditions agreed to by ComSouth (Host) and the other telecommunications carriers (Guests) contained in this Section, except where the BellSouth Premises is located within a leased space and BellSouth is prohibited by said lease from offering such an option to ComSouth. BellSouth shall be notified in writing by ComSouth upon the execution of any agreement between the Host and its Guest(s) prior to the submission of an application. Further, such notification shall include the name of the Guest(s), the term of the agreement, and a certification by ComSouth that said agreement imposes upon the Guest(s) the same terms and conditions for Collocation Space as set forth in this Attachment between BellSouth and ComSouth. The term of the agreement between the Host and its Guest(s) shall not exceed the term of this Agreement between BellSouth and ComSouth.

3.3.2 ComSouth, as the Host, shall be the sole interface and responsible Party to BellSouth for the assessment and billing of rates and charges contained within this Attachment and for the purposes of ensuring that the safety and security requirements of this Attachment are fully complied with by the Guest(s), its employees and agents. BellSouth shall provide ComSouth with a pro-ration of the costs of the Collocation Space based on the number of collocators and the space used by each. There will be a minimum charge of one (1) bay/rack per Host/Guest. In addition to the above, ComSouth shall be the responsible Party to BellSouth for the purpose of submitting applications for initial and additional equipment placement for the Guest(s).

- 3.3.3 Notwithstanding the foregoing, the Guest(s) may submit service orders directly to BellSouth to request the provisioning of interconnecting facilities between BellSouth and the Guest(s), the provisioning of services, and/or access to Network Elements. The bill for these interconnecting facilities, services and Network Elements will be charged to the Guest(s) pursuant to the applicable BellSouth Tariff or the Guest's Interconnection Agreement with BellSouth.
- 3.3.4 ComSouth shall indemnify and hold harmless BellSouth from any and all claims, actions, causes of action, of whatever kind or nature arising out of the presence of ComSouth's Guest(s) in the Collocation Space, except to the extent caused by BellSouth's sole negligence, gross negligence, or willful misconduct.
- 3.4 Adjacent Collocation
- 3.4.1 Subject to technical feasibility and space availability, BellSouth will permit an adjacent collocation arrangement (Adjacent Arrangement) on BellSouth Premises' property only when space within the requested BellSouth Premises is legitimately exhausted and where the Adjacent Arrangement does not interfere with access to existing or planned structures or facilities on the BellSouth Premises' property. An Adjacent Arrangement shall be constructed or procured by ComSouth or ComSouth's BellSouth Certified Supplier and must be in conformance with the provisions of BellSouth's design and construction specifications. Further, ComSouth shall construct, procure, maintain and operate said Adjacent Arrangement pursuant to all of the applicable rates, terms and conditions set forth in this Attachment.
- 3.4.2 If ComSouth requests Adjacent Collocation, pursuant to the conditions stated in Section 3.4 above, ComSouth must arrange with a BellSouth Certified Supplier to construct or procure the Adjacent Arrangement structure in accordance with BellSouth's specifications. BellSouth will provide the appropriate specifications upon request. Where local building codes require specifications more stringent than BellSouth's own specifications, ComSouth and ComSouth's BellSouth Certified Supplier shall comply with the more stringent local building code requirements. ComSouth's BellSouth Certified Supplier shall be responsible for filing and obtaining any and all necessary zoning, permits and/or licenses for such construction. ComSouth's BellSouth Certified Supplier shall bill ComSouth directly for all work performed for ComSouth to comply with this Attachment. BellSouth shall have no liability for, nor responsibility to pay such charges imposed by ComSouth's BellSouth Certified Supplier. ComSouth must provide the local BellSouth contact with two (2) cards, keys or other access devices used to gain entry into the locked enclosure. Except in the case of an emergency, BellSouth will not access ComSouth's locked enclosure prior to notifying ComSouth at least forty-eight (48) hours or two (2) business days, whichever is greater, before access to the Collocation Space is required.
- 3.4.3 ComSouth must submit its Adjacent Arrangement construction plans and specifications to BellSouth when it places its Firm Order. BellSouth shall review ComSouth's plans and specifications prior to the construction of an Adjacent

Arrangement to ensure ComSouth's compliance with BellSouth's specifications. BellSouth shall complete its review within fifteen (15) days after receipt of the plans and specifications from ComSouth for the Adjacent Arrangement. BellSouth may inspect the Adjacent Arrangement during and after construction is completed to ensure that it is constructed according to ComSouth's submitted plans and specifications. If BellSouth decides to inspect the completed Adjacent Arrangement, BellSouth will complete its inspection within fifteen (15) days after receipt of ComSouth's written notification that the Adjacent Arrangement has been completed. Within seven (7) days after BellSouth has completed its inspection of ComSouth's Adjacent Arrangement, BellSouth shall require ComSouth, at ComSouth's expense, to remove or correct any structure that does not meet its submitted plans and specifications or BellSouth's specifications, as applicable.

3.4.4 ComSouth shall provide a concrete pad, the structure housing the Adjacent Arrangement, HVAC, lighting and all of the facilities that are required to connect the structure (i.e., racking, conduits, etc.) to the BellSouth point of demarcation. At ComSouth's option and where the local authority having jurisdiction permits, BellSouth shall provide an AC power source and access to physical Collocation services and facilities, subject to the same nondiscriminatory requirements as those applicable to any other physical Collocation arrangement.

3.5 Direct Connect

3.5.1 BellSouth will permit ComSouth to directly interconnect between its own physical/virtual Collocation Spaces within the same BellSouth Premises (Direct Connect). ComSouth shall contract with a BellSouth Certified Supplier to place the Direct Connect, which shall be provisioned using facilities owned by ComSouth. A Direct Connect shall utilize BellSouth common cable support structure. There will be a recurring charge per linear foot, per cable, of the actual common cable support structure used by ComSouth to provision the Direct Connect between its physical/virtual Collocation Spaces. In those instances where ComSouth's physical/virtual Collocation Spaces are contiguous in the central office, ComSouth will have the option of using ComSouth's own technicians to deploy the Direct Connect using either electrical or optical facilities between its Collocation Spaces by constructing its own dedicated cable support structure. ComSouth will deploy such electrical or optical connections directly between its own equipment without being routed through BellSouth's equipment or common cable support structure. ComSouth may not self-provision a Direct Connect on any BellSouth distribution frame, Point of Termination (POT) Bay, Digital System Cross-Connect (DSX) panel or Light Guide Cross-Connect (LGX) panel. ComSouth is solely responsible for ensuring the integrity of the signal.

3.5.2 To place an order for a Direct Connect, ComSouth must submit an Initial Application or Subsequent Application to BellSouth. If no modification to the Collocation Space is requested other than the placement of a Direct Connect, the Co-Carrier Cross Connect/Direct Connect Application Fee for Direct Connect, as defined in Exhibit B, will apply. If other modifications are requested, in addition

to the placement of a Direct Connect, either an Initial Application Fee or a Subsequent Application Fee will apply, pursuant to Section 6.2 below. BellSouth will bill this nonrecurring charge on the date that BellSouth provides an Application Response to ComSouth.

3.6 Co-Carrier Cross Connect (CCXC)

3.6.1 A CCXC is a cross connection between ComSouth and another collocated telecommunications carrier, other than BellSouth, in the same BellSouth Premises. Where technically feasible, BellSouth will permit ComSouth to interconnect between its Collocation Space(s) and the physical/virtual collocation space(s) of another collocated telecommunications carrier(s) within the same BellSouth Premises via a CCXC, pursuant to the FCC's Rules. The other collocated telecommunications carrier's agreement must also contain CCXC rates, terms and conditions before BellSouth will permit the provisioning of a CCXC between the two (2) collocated carriers. The applicable BellSouth charges will be assessed to ComSouth upon ComSouth's request for the CCXC.

ComSouth is prohibited from using the Collocation Space for the sole or primary purpose of cross-connecting to other collocated telecommunications carriers.

3.6.2 ComSouth must contract with a BellSouth Certified Supplier to place the CCXC. The CCXC shall be provisioned using facilities owned by ComSouth. Such cross-connections to other collocated telecommunications carriers may be made using either electrical or optical facilities. ComSouth shall be responsible for providing a LOA, with the application, to BellSouth from the other collocated telecommunications carrier to which it will be cross-connecting. The CCXC shall utilize BellSouth common cable support structure. There will be a recurring charge per linear foot, per cable, of the common cable support structure used by ComSouth to provision the CCXC to the other collocated telecommunications carrier. In those instances where ComSouth's equipment and the equipment of the other collocated telecommunications carrier are located in contiguous caged Collocation Space, ComSouth may use its own technicians to install the CCXC using either electrical or optical facilities between the equipment of both collocated telecommunications carriers by constructing a dedicated cable support structure between the two (2) contiguous cages. ComSouth shall deploy such electrical or optical cross-connections directly between its own equipment and the equipment of the other collocated telecommunications carrier without being routed through BellSouth's equipment or, in the case of a CCXC provisioned between contiguous collocation spaces, common cable support structure. ComSouth shall not provision CCXC on any BellSouth distribution frame, POT Bay, DSX panel or LGX panel. ComSouth is solely responsible for ensuring the integrity of the signal.

3.6.3 To place an order for a CCXC, ComSouth must submit an application to BellSouth. If no modification to the Collocation Space is requested other than the placement of a CCXC, the Co-Carrier Cross Connect/Direct Connect Application Fee for a CCXC, as defined in Exhibit B, will apply. If other modifications are requested, in addition to the placement of a CCXC, either an Initial Application or

a Subsequent Application Fee will apply, pursuant to Section 6.2 below. BellSouth will bill this nonrecurring charge on the date that it provides an Application Response to ComSouth.

4 Occupancy

- 4.1 Space Ready Notification. BellSouth will notify ComSouth in writing when the Collocation Space is ready for occupancy (Space Ready Date).
- 4.2 Acceptance Walkthrough. ComSouth will schedule and complete an acceptance walkthrough of new or additional provisioned Collocation Space with BellSouth within fifteen (15) days after the Space Ready Date. BellSouth will correct any identified deviations from ComSouth's original or jointly amended application within seven (7) days after the walkthrough, unless the Parties mutually agree upon a different time frame. BellSouth will then establish a new Space Ready Date. Another acceptance walkthrough will be scheduled and conducted within fifteen (15) days after the new Space Ready Date. This follow-up acceptance walkthrough will be limited to only those deviations identified in the initial walkthrough. If ComSouth completes its acceptance walkthrough within the fifteen (15) day interval associated with the applicable Space Ready Date, billing will begin upon the date of ComSouth's acceptance of the Collocation Space (Space Acceptance Date). In the event ComSouth fails to complete an acceptance walkthrough within the fifteen (15) day interval associated with the applicable Space Ready Date, the Collocation Space shall be deemed accepted by ComSouth on the Space Ready Date and billing will commence from that date.
- 4.3 Early Space Acceptance. If ComSouth decides to occupy the Collocation Space prior to the Space Ready Date, the date ComSouth executes the Agreement for Customer Access and Acceptance to Unfinished Collocation Space is the date that will be deemed the Space Acceptance Date and billing will begin from that date.
- 4.4 Equipment Installation. ComSouth shall notify BellSouth in writing that its collocation equipment installation is complete. ComSouth's collocation equipment installation is complete when ComSouth's equipment is connected to BellSouth's network for the purpose of provisioning Telecommunication Services to ComSouth's customers. BellSouth may refuse to accept any orders for cross-connects until it has received such notice from ComSouth.
- 4.5 Termination of Occupancy.
- 4.5.1 In addition to any other provisions addressing termination of occupancy in this Agreement, ComSouth may terminate its occupancy of a particular Collocation Space by submitting a Subsequent Application requesting termination of occupancy for such Collocation Space. Such termination shall be effective upon BellSouth's acceptance of the Space Relinquishment Form. Billing for monthly recurring charges will cease on the date that ComSouth and BellSouth conduct an inspection of the terminated space and jointly sign off on the Space Relinquishment Form or on the date that ComSouth signs off on the Space Relinquishment Form and sends this form to BellSouth, provided no discrepancies are found during BellSouth's subsequent inspection of the

terminated space. If the subsequent inspection by BellSouth reveals any discrepancies, billing will cease on the date that BellSouth and ComSouth jointly conduct an inspection, confirming that ComSouth has corrected all of the noted discrepancies identified by BellSouth. A Subsequent Application Fee will not apply for the termination of occupancy; however, specific disconnect fees may apply to the services terminating to such Collocation Space. The particular disconnect fees that would apply in each state are contained in Exhibit B.

- 4.5.2 Upon termination of occupancy, ComSouth, at its sole expense, shall remove its equipment and any other property owned, leased or controlled by ComSouth from the Collocation Space. ComSouth shall have thirty (30) days from the Bona Fide Firm Order (BFFO) date (Termination Date) to complete such removal, including the removal of all equipment and facilities of ComSouth's Guest(s), unless ComSouth's Guest(s) has assumed responsibility for the Collocation Space housing the Guest(s)'s equipment and executed the appropriate documentation required by BellSouth to transfer the Collocation Space to the Guest(s) prior to ComSouth's Termination Date.
- 4.5.3 ComSouth shall continue the payment of all monthly recurring charges to BellSouth until the date ComSouth, and if applicable ComSouth's Guest(s), has fully vacated the Collocation Space and the Space Relinquishment Form has been accepted by BellSouth. If ComSouth or ComSouth's Guest(s) fails to vacate the Collocation Space within thirty (30) days from the Termination Date, BellSouth shall have the right to remove and dispose of the equipment and any other property of ComSouth or ComSouth's Guest(s), in any manner that BellSouth deems fit, at ComSouth's expense and with no liability whatsoever for ComSouth's property or ComSouth's Guest(s) property.
- 4.5.4 Upon termination of ComSouth's right to occupy specific Collocation Space, the Collocation Space will revert back to BellSouth's central office space inventory. ComSouth shall surrender the Collocation Space to BellSouth in the same condition as when it was first occupied by ComSouth, with the exception of ordinary wear and tear, unless otherwise agreed to by the Parties. ComSouth's BellSouth Certified Supplier shall be responsible for updating and making any necessary changes to BellSouth's records as required by BellSouth specifications including, but not limited to, BellSouth's Central Office Record Drawings and ERMA Records. ComSouth shall be responsible for the cost of removing any ComSouth constructed enclosure, as well as any supporting structures (e.g., racking, conduits, power cables, etc.), by the Termination Date and restoring the grounds to their original condition.

5 Use of Collocation Space

5.1 Equipment Type

- 5.1.1 BellSouth shall permit the collocation and use of any equipment necessary for interconnection to BellSouth's network and/or access to BellSouth's unbundled network elements in the provision of Telecommunications Services, as the term "necessary" is defined by FCC 47 C.F.R. § 51.323 (b). The primary purpose and

function of any equipment collocated in a BellSouth Premises must be for interconnection to BellSouth's network or access to BellSouth's unbundled network elements in the provision of Telecommunications Services. Equipment is necessary for interconnection if an inability to deploy that equipment would, as a practical, economical, or operational matter, preclude the requesting carrier from obtaining interconnection with BellSouth at a level equal in quality to that which BellSouth obtains within its own network or what BellSouth provides to any affiliate, subsidiary, or other party.

- 5.1.2 Examples of equipment that would not be considered necessary include, but are not limited to: traditional circuit switching equipment, equipment used exclusively for call-related databases, computer servers used exclusively for providing information services, OSS equipment used to support collocated telecommunications carrier network operations, equipment that generates customer orders, manages trouble tickets or inventory, or stores customer records in centralized databases, etc. BellSouth will determine upon receipt of an application if the requested equipment is necessary based on the criteria established by the FCC. Multifunctional equipment placed on a BellSouth Premises must not place any greater relative burden on BellSouth's property than comparable single-function equipment. BellSouth reserves the right to allow the collocation of any equipment on a nondiscriminatory basis.
- 5.1.3 Such equipment must, at a minimum, meet the following Telcordia Network Equipment Building Systems (NEBS) General Equipment Requirements: for Central Offices Criteria Level 1 requirements as outlined in Telcordia Special Report SR-3580, Issue 1 and for Remote Sites Criteria Level 3 requirements as outlined in the Telcordia Special report SR-3580, Issue 1. Except where otherwise required by a Commission, BellSouth shall comply with the applicable FCC rules relating to denial of collocation equipment based on ComSouth's failure to comply with this Section.
- 5.1.3.1 To the extent ComSouth wishes to place equipment in its collocation that does not meet the standards set forth in 5.1.3, ComSouth may request in writing, pursuant to the Notices section of the General Terms & Conditions, a waiver to such standards. BellSouth may provide a waiver in its sole discretion.
- 5.1.4 At a Remote Site, all ComSouth equipment installation shall comply with BellSouth TR 73503-11h, "Grounding - Engineering Procedures". Metallic cable sheaths and metallic strength members of optical fiber cables as well as the metallic cable sheaths of all copper conductor cables shall be bonded to the designated grounding bus for the Remote Site Location. All copper conductor pairs, working and non-working, shall be equipped with a solid-state protector unit (over-voltage protection only), which has been listed by a nationally recognized testing laboratory.
- 5.2 Terminations. ComSouth shall not request more DS0, DS1, DS3 and/or optical terminations for a collocation arrangement than the total port or termination capacity of the equipment physically installed in the Collocation Space. The total

capacity of the equipment collocated in the Collocation Space will include equipment contained in an application, as well as any equipment already placed in the Collocation Space. If full network termination capacity of the equipment being installed is not requested in the application submitted by ComSouth, additional network terminations for the installed equipment will require the submission of a Subsequent Application. In the event ComSouth submits an application for terminations that will exceed the total capacity of the collocated equipment, ComSouth will be informed of the discrepancy by BellSouth and required to submit a revision to the application.

- 5.3 Security Interest in Equipment. Commencing with the most current calendar quarter after the Effective Date of this Agreement, and thereafter with respect to each subsequent calendar quarter during the term of this Agreement, ComSouth will, no later than thirty (30) days after the close of such calendar quarter, provide a report to ICS Collocation Product Management, Room 34th Floor, 675 W. Peachtree Street, Atlanta, Georgia 30375, listing any equipment in the Collocation Space (i) that was added during the calendar quarter to which such report pertains, and (ii) for which there is a UCC-1 lien holder or to another entity that has a secured financial interest in such equipment (Secured Equipment). If no Secured Equipment has been installed within a given calendar quarter, no report shall be due hereunder in connection with such calendar quarter.
- 5.4 No Marketing. ComSouth shall not use the Collocation Space for marketing purposes, nor shall it place any identifying signs or markings outside the Collocation Space or on the grounds of the BellSouth Premises.
- 5.5 Equipment Identification. ComSouth shall place a plaque or affix other identification (e.g., stenciling or labeling) to each piece of ComSouth's equipment, including the appropriate emergency contacts with their corresponding telephone numbers, in order for BellSouth to properly identify ComSouth's equipment in the case of an emergency. For caged Collocation Space, such identification must be placed on a plaque affixed to the outside of the caged enclosure.
- 5.6 Entrance Facilities.
- 5.6.1 ComSouth may elect to place ComSouth-owned or ComSouth leased fiber entrance facilities into its Collocation Space. BellSouth will designate the point of interconnection in close proximity to the BellSouth Premises housing the Collocation Space, such as at an entrance manhole or a cable vault for Central Offices, which is physically accessible by both Parties. For Central Offices, ComSouth will provide and place fiber cable in the entrance manhole of sufficient length to be pulled through conduit and into the splice location. ComSouth will provide and install a sufficient length of fire retardant riser cable, to which BellSouth will splice the entrance cable. The fire retardant riser cable will extend from the splice location to ComSouth's equipment in ComSouth's Collocation Space. In the event ComSouth utilizes a non-metallic, riser-type entrance facility, a splice will not be required. For Remote Terminals ComSouth will provide and

place copper cable through conduit from the Remote Site Collocation Space to the feeder distribution interface. Such copper cable must be of sufficient length to reach the splice location for splicing by BellSouth. ComSouth must contact BellSouth for authorization and instruction prior to placing any entrance facility cable in an entrance manhole or cable vault. ComSouth is responsible for the maintenance of the entrance facilities. Nonrecurring charges for cable installation will be assessed on a per cable basis as set forth in Exhibit B upon receipt of ComSouth's BFFO. Recurring charges for the cable support structure will be billed at the rates set forth in Exhibit B.

- 5.6.2 Central Office Microwave Transmission Facilities. At ComSouth's request, BellSouth will accommodate, where technically feasible and space is available, a microwave entrance facility, pursuant to separately negotiated rates, terms and conditions.
- 5.6.3 Central Office Copper and Coaxial Cable Entrance Facilities. In Georgia, BellSouth shall permit ComSouth to use copper or coaxial cable entrance facilities, if approved by the Commission, but only in those rare instances where ComSouth demonstrates a necessity and entrance capacity is not at or near exhaust in a particular BellSouth Premises in which ComSouth's Collocation Space is located. Notwithstanding the foregoing, in the case of adjacent collocation, copper facilities may be used between the adjacent collocation arrangement and the central office demarcation point, unless BellSouth determines that limited space is available for the placement of these entrance facilities.
- 5.7 Dual Entrance Facilities at a Central Office. BellSouth will provide at least two (2) interconnection points at each Central Office where at least two (2) such interconnection points are available and capacity exists. Upon receipt of a request by ComSouth for dual entrance facilities to its physical Collocation Space, BellSouth shall provide ComSouth with information regarding BellSouth's capacity to accommodate the requested dual entrance facilities. If conduit in the serving manhole(s) is available and is not reserved for another purpose or for utilization within twelve (12) months of the receipt of an application for collocation, BellSouth will make the requested conduit space available for the installation of a second entrance facility to ComSouth's Collocation Space. The location of the serving manhole(s) will be determined at the sole discretion of BellSouth. Where dual entrance facilities are not available due to a lack of capacity, BellSouth will provide this information to ComSouth in the Application Response.
- 5.8 Shared Use
- 5.8.1 ComSouth may utilize spare capacity on an existing telecommunications carrier's entrance facility for the purpose of obtaining an entrance facility to ComSouth's Collocation Space within the same BellSouth Premises.
- 5.8.2 BellSouth shall allow the splice, as long as the fiber is non-working dark fiber. ComSouth must arrange with BellSouth in accordance with BellSouth's Special

Construction Procedures, RL93-11-030BT, and provide a LOA from the other telecommunications carrier authorizing BellSouth to perform the splice of the ComSouth-provided riser cable to the spare capacity on the other telecommunications carrier's entrance facility. If ComSouth desires to allow another telecommunications carrier to use its entrance facilities, the telecommunications carrier must arrange with BellSouth in accordance with BellSouth's Special Construction Procedures, RL93-11-030BT, and provide a LOA from ComSouth authorizing BellSouth to perform the splice of the telecommunications carrier's provided riser cable to the spare capacity on ComSouth's entrance facility.

5.9 Demarcation Point

5.9.1 BellSouth will designate the point(s) of demarcation between ComSouth's equipment and/or network facilities and BellSouth's network facilities. For 2-wire and 4-wire connections, the demarcation point shall be a common block on the BellSouth designated conventional distribution frame. ComSouth shall be responsible for providing the common block and cabling and ComSouth's BellSouth Certified Supplier shall be responsible for installing and properly labeling/stenciling the common block and any necessary cabling identified in Section 7 below. For DS1, DS3, STS1, and optical terminations, BellSouth shall designate, provide, and install demarcation point hardware on a per arrangement basis. ComSouth shall be responsible for providing, and ComSouth's BellSouth Certified Supplier shall be responsible for installing any necessary cabling and properly labeling/stenciling the demarcation point hardware for terminations identified in Section 7 below.

5.9.2 ComSouth or its agent must install, maintain and operate the equipment/facilities on its side of the demarcation point, pursuant to Section 5.10 below and may self-provision cross-connects that may be required within its own Collocation Space to activate service requests.

5.10 Equipment and Facilities. ComSouth, or if required by this Attachment, ComSouth's BellSouth Certified Supplier, is solely responsible for the design, engineering, installation, testing, provisioning, performance, monitoring and maintenance/repair of the equipment and network facilities used by ComSouth, which must be performed in compliance with all applicable BellSouth specifications. Such equipment and network facilities may include, but are not limited to, cable(s), equipment, and POT connections. ComSouth and its designated BellSouth Certified Supplier must follow and comply with all BellSouth specifications outlined in the following BellSouth Technical Requirements: TR 73503, TR 73519, TR 73572 and TR 73564.

5.11 BellSouth's Access to Collocation Space

5.11.1 From time to time, BellSouth may require access to ComSouth's Collocation Space. BellSouth retains the right to access ComSouth's Collocation Space for the purpose of making BellSouth equipment and building modifications (e.g., installing, altering or removing racking, ducts, electrical wiring, HVAC, and

cabling). In such cases, BellSouth will give notice to ComSouth at least forty-eight (48) hours before access to ComSouth's Collocation Space is required. ComSouth may elect to be present whenever BellSouth performs work in the ComSouth's Collocation Space. The Parties agree that ComSouth will not bear any of the expense associated with this type of work.

5.11.2 In the case of an emergency, BellSouth will provide oral notice of entry as soon as reasonably practicable after such entry.

5.11.3 ComSouth must provide the local BellSouth Central Office Building Contact with two (2) Access Devices that will allow BellSouth entry into any enclosed and locked Collocation Space including, but not limited to, an Adjacent Arrangement, pursuant to the requirements contained in this Section.

5.12 ComSouth's Access

5.12.1 Pursuant to Section 12 below, ComSouth shall have access to its Collocation Space twenty-four (24) hours a day, seven (7) days a week. ComSouth agrees to provide the name, date of birth and either the social security number or driver's license number of each employee, supplier or agent of ComSouth or ComSouth's Guest(s) with ComSouth's written request for access keys or cards (Access Devices) for specific BellSouth Premises, prior to the issuance of said Access Devices, using Form RF-2906-C, the "CLEC and CLEC Certified Supplier Access Request and Acknowledgement" form. The appropriate key acknowledgement forms (the "Collocation Acknowledgement Sheet" for access cards and the "Key Acknowledgement Form" for keys) must be signed by ComSouth and returned to BellSouth Access Management within fifteen (15) days of ComSouth's receipt of these forms. Failure to return these properly acknowledged forms will result in the subsequent access key or card requests being held by BellSouth until the proper acknowledgement documents have been received by BellSouth and reflect current information. Charges for Security Access System and for Security Access Devices will be billed at the rates set forth in Exhibit B. Access Devices may not be duplicated under any circumstances. ComSouth agrees to be responsible for all Access Devices and for the return of all Access Devices in the possession of ComSouth's employees, suppliers, agents or Guests after termination of the employment relationship, the contractual obligation with ComSouth ends, upon the termination of this Agreement, or upon the termination of occupancy of Collocation Space in a specific BellSouth Premises. ComSouth shall pay all applicable charges associated with lost or stolen Access Devices.

5.12.2 ComSouth must submit to BellSouth the completed Access Control Request Form for all employees, suppliers, agents or Guests requiring access to a BellSouth Premises at least thirty (30) days prior to the date ComSouth desires to gain access to the Collocation Space. In order to permit reasonable access during construction of the Collocation Space, ComSouth may submit a request for its one (1) free accompanied site visit to its designated Collocation Space at any time subsequent to BellSouth's receipt of the BFFO. In the event ComSouth desires

access to its designated Collocation Space after the first accompanied free visit and ComSouth's access request form(s) has not been approved by BellSouth or ComSouth has not yet submitted an access request form to BellSouth, ComSouth shall be permitted to access the Collocation Space accompanied by a BellSouth security escort, at ComSouth's expense, which will be assessed pursuant to the Security Escort fees contained in Exhibit B. ComSouth must request that escorted access be provided by BellSouth to ComSouth's designated Collocation Space at least three (3) business days prior to the date such access is desired. A BellSouth security escort will be required whenever ComSouth or its approved agent or supplier requires access to the entrance manhole.

5.13 Lost or Stolen Access Devices. ComSouth shall immediately notify BellSouth in writing when any of its Access Devices have been lost or stolen. If it becomes necessary for BellSouth to re-key buildings or deactivate an Access Device as a result of a lost or stolen Access Device(s) or for failure of ComSouth's employees, suppliers, agents or Guest(s) to return an Access Device(s), ComSouth shall pay for the costs of re-keying the building or deactivating the Access Device(s).

5.14 Interference or Impairment

5.14.1 Notwithstanding any other provisions of this Attachment, ComSouth shall not use any product or service provided under this Agreement, any other service related thereto or used in combination therewith, or place or use any equipment or facilities in any manner that (1) significantly degrades, interferes with or impairs service provided by BellSouth or any other entity or any person's use of its telecommunications services; (2) endangers or damages the equipment, facilities or any other property of BellSouth or any other entity or person; (3) compromises the privacy of any communications routed through the BellSouth Premises; or (4) creates an unreasonable risk of injury or death to any individual or to the public. If BellSouth reasonably determines that any equipment or facilities of ComSouth violates the provisions of this paragraph, BellSouth shall provide written notice to ComSouth, which shall direct ComSouth to cure the violation within forty-eight (48) hours of ComSouth's receipt of written notice or, if such cure is not feasible, at a minimum, to commence curative measures within twenty-four (24) hours and exercise reasonable diligence to complete such measures as soon as possible thereafter. After receipt of the notice, the Parties agree to consult immediately and, if necessary, to conduct an inspection of the Collocation Space.

5.14.2 Except in the case of the deployment of an advanced service which significantly degrades the performance of other advanced services or traditional voice band services, if ComSouth fails to cure the violation within forty-eight (48) hours or, if such cure is not possible, to commence curative action within twenty-four (24) hours and exercise reasonable diligence to complete such action as soon as possible, or if the violation is of a character that poses an immediate and substantial threat of damage to property or injury or death to any person, or any other significant degradation, interference or impairment of BellSouth's or another entity's service, then and only in that event, BellSouth may take such

action as it deems necessary to eliminate such threat including, without limitation, the interruption of electrical power to ComSouth's equipment and/or facilities. BellSouth will endeavor, but is not required, to provide notice to ComSouth prior to the taking of such action and BellSouth shall have no liability to ComSouth for any damages arising from such action, except to the extent that such action by BellSouth constitutes willful misconduct.

5.14.3 For purposes of this Section, the term "significantly degrades" shall be defined as an action that noticeably impairs a service from a user's perspective. In the case of the deployment of an advanced service which significantly degrades the performance of other advanced services or traditional voice band services and ComSouth fails to cure the violation within forty-eight (48) hours, or if such cure is not possible, to commence curative action within twenty-four (24) hours and exercise reasonable diligence to complete such action as soon as possible, BellSouth will establish before the appropriate Commission that the technology deployed is causing the significant degradation. Any claims of network harm presented to ComSouth or, if subsequently necessary, the Commission must be provided by BellSouth with specific and verifiable information. When BellSouth demonstrates that a certain technology deployed by ComSouth is significantly degrading the performance of other advanced services or traditional voice band services, ComSouth shall discontinue deployment of that technology and migrate its customers to other technologies that will not significantly degrade the performance of such services. Where the only degraded service itself is a known disturber, and the newly deployed technology satisfies at least one of the criteria for a presumption that it is acceptable for deployment, pursuant to 47 C.F.R. § 51.230, the degraded service shall not prevail against the newly-deployed technology.

5.15 Personalty and Its Removal. Facilities and equipment placed by ComSouth in the Collocation Space shall not become a part of the Collocation Space, even if nailed, screwed or otherwise fastened to the Collocation Space, but shall retain their status as personal property and may be removed by ComSouth at any time. Any damage caused to the Collocation Space by ComSouth's employees, suppliers, agents or Guests during the installation or removal of such property shall be promptly repaired by ComSouth at its sole expense. If ComSouth decides to remove equipment and/or facilities from its Collocation Space and the removal requires no physical work be performed by BellSouth and ComSouth's physical work includes, but is not limited to, power reduction, cross-connects, or tie pairs, BellSouth will bill ComSouth the Administrative Only Application Fee associated with the type of removal activity performed by ComSouth, as set forth in Exhibit B. This nonrecurring fee will be billed on the date that BellSouth provides an Application Response to ComSouth.

5.16 Alterations. Under no condition shall ComSouth or any person acting on behalf of ComSouth make any rearrangement, modification, augment, improvement, addition, and/or other alteration which could affect in any way space, power, HVAC, and/or safety considerations to the Collocation Space or the BellSouth

Premises, hereinafter referred to individually or collectively as “Alterations”, without the express written consent of BellSouth, which shall not be unreasonably withheld. The cost of any such Alteration shall be paid by ComSouth. An Alteration shall require the submission of a Subsequent Application and will result in the assessment of the applicable application fee associated with the type of alteration requested, as set forth in Sections 6.2.1 and 7.1.4 below, which will be billed by BellSouth on the date that BellSouth provides ComSouth with an Application Response.

- 5.17 Central Office Janitorial Service. ComSouth shall be responsible for the general upkeep of its Collocation Space. ComSouth shall arrange directly with a BellSouth Certified Supplier for janitorial services applicable to caged Collocation Space. Upon request, BellSouth shall provide a list of such suppliers on a BellSouth Premises-specific basis.
- 5.18 Upkeep of Remote Collocation Space. ComSouth shall be responsible for the general upkeep and cleaning of the Remote Collocation Space. ComSouth shall be responsible for removing any of ComSouth’s debris from the Remote Collocation Space and from in and around the Remote Site Location on each visit.

6 Ordering and Preparation of Collocation Space

- 6.1 Initial Application. For ComSouth’s or ComSouth’s Guest’s(s’) initial equipment placement, ComSouth shall input a physical Expanded Interconnection Application Document (Initial Application) for physical Collocation Space directly into BellSouth’s electronic application (e.App) system for processing. The Initial Application is considered Bona Fide when it is complete and accurate, meaning that all of the required fields on the Initial Application are completed with the appropriate type of information. An Initial Application Fee, as set forth in Exhibit B, will apply to each Initial Application submitted by ComSouth for Central Office or Remote Site Collocation, as applicable, and will be billed by BellSouth on the date BellSouth provides ComSouth with an Application Response.
- 6.1.1 For Remote Site Collocation, a request for additional space at a later date will require the submission of an Initial Application. The installation of additional shelves/equipment within an existing bay does not require an Initial Application.
- 6.2 Subsequent Application. In the event ComSouth or ComSouth’s Guest(s) desires to modify its use of the Collocation Space in a Central Office after a BFFO, ComSouth shall complete an application that contains all of the detailed information associated with a requested Alteration of the Collocation Space, as defined in Section 5.15 above (Subsequent Application). The Subsequent Application will be considered Bona Fide when it is complete and accurate, meaning that all of the required fields on the Subsequent Application have been completed with the appropriate type of information associated with the requested Alteration. BellSouth shall determine what modifications, if any, to the BellSouth Premises are required to accommodate the change(s) requested by ComSouth in

the Subsequent Application. Such modifications to the BellSouth Premises may include, but are not limited to, floor loading changes, changes necessary to meet HVAC requirements, changes to power plant requirements, equipment additions, etc.

6.2.1 Subsequent Application Fees. The application fee paid by ComSouth for an Alteration in a Central Office shall be dependent upon the level of assessment needed to provide a complete Application Response for the Alteration requested. Where the Subsequent Application does not require provisioning or construction work, but requires BellSouth to perform an administrative activity, an Administrative Only Application Fee shall apply as set forth in Exhibit B. The Administrative Only Application Fee will apply to Subsequent Applications associated with a transfer of ownership of the Collocation Space, the addition, exchange or removal of equipment from the Collocation Space (where the removal requires no physical work to be performed by BellSouth which require no additional space, power or terminations to be provided to ComSouth's collocation arrangement), and a virtual-to-physical conversion (in place). The Co-Carrier Cross Connect/Direct Connect Application Fee will apply when ComSouth submits a Subsequent Application for a direct connection between its own physical and virtual Collocation Space(s) in the same BellSouth Central Office or between its physical or virtual Collocation Space and that of another collocated telecommunications carrier within the same BellSouth Central Office. The fee for a Subsequent Application, for which the Alteration requested has limited effect (e.g., requires limited assessment and sufficient cable support structure, HVAC, power and terminations are available), shall be the Subsequent Application Fee, as set forth in Exhibit B. The appropriate nonrecurring application fee will be billed on the date that BellSouth provides ComSouth with an Application Response.

6.3 Space Preferences. If ComSouth has previously requested and received a Space Availability Report for the BellSouth Premises, ComSouth may submit up to three (3) space preferences on its application by identifying the specific space identification numbers referenced on the Space Availability Report for the space it is requesting. In the event BellSouth cannot accommodate ComSouth's space preference(s), ComSouth may accept the space allocated by BellSouth or cancel its application and submit another application requesting additional space preferences for the same BellSouth Premises. This application will be treated as a new application and the appropriate application fee will apply. The application fee will be billed by BellSouth on the date that BellSouth provides ComSouth with an Application Response.

6.4 Space Availability Notification

6.4.1 BellSouth will respond to an application within ten (10) days as to whether space is available or not available within the requested BellSouth Premises. BellSouth's e.App system will reflect when ComSouth's application is Bona Fide. If the application cannot be Bona Fide, BellSouth will identify what revisions are necessary for the application to become Bona Fide.

- 6.4.2 If the amount of space requested is not available, BellSouth will notify ComSouth of the amount of space that is available and no application fee will apply. When BellSouth's response includes an amount of space less than that requested by ComSouth or space that is configured differently, no application fee will apply. If ComSouth decides to accept the available space, ComSouth must resubmit its application to reflect the actual space available, including the configuration of the space, prior to submitting a BFFO. When ComSouth resubmits its application to accept the available space, BellSouth will bill ComSouth the appropriate application fee.
- 6.5 Denial of Application. If BellSouth notifies ComSouth that no space is available (Denial of Application), BellSouth will not assess an application fee to ComSouth. After notifying ComSouth that BellSouth has no available space in the requested BellSouth Premises, BellSouth will allow ComSouth, upon request, to tour the entire BellSouth Premises within ten (10) days of such Denial of Application. In order to schedule this tour, BellSouth must receive the request for the tour of the BellSouth Premises within five (5) days of the Denial of Application.
- 6.6 Petition for Waiver. Upon Denial of Application, BellSouth will timely file a petition with the appropriate Commission pursuant to 47 U.S.C. § 251(c)(6). BellSouth shall provide to the Commission any information requested by that Commission. Such information shall include which space, if any, BellSouth or any of BellSouth's affiliates have reserved for future use and a detailed description of the specific future uses for which the space has been reserved. Subject to an appropriate nondisclosure agreement or provision, BellSouth shall permit ComSouth to inspect any floor plans or diagrams that BellSouth provides to the Commission.
- 6.7 Waiting List
- 6.7.1 On a first-come, first-serve basis, which is governed by the date of receipt of an application or Letter of Intent, BellSouth will maintain a waiting list of requesting telecommunications carriers that have either received a Denial of Application or, where it is publicly known that a BellSouth Premises is out of space, have submitted a Letter of Intent to collocate in that BellSouth Premises. BellSouth will notify each telecommunications carrier on the waiting list that can be accommodated by the amount of space that becomes available, according to the position of the telecommunications carrier on said waiting list.
- 6.7.2 When physical Collocation Space becomes available, ComSouth must submit an updated, complete and accurate application to BellSouth within thirty (30) days of notification by BellSouth that physical Collocation Space will be available in the requested BellSouth Premises previously out of space. If ComSouth has originally requested caged Collocation Space and cageless Collocation Space becomes available, ComSouth may refuse such space and notify BellSouth in writing, within the thirty (30) day timeframe referenced above, that ComSouth wishes to maintain its place on the waiting list for caged physical Collocation

Space, without accepting the available cageless Collocation Space.

- 6.7.3 ComSouth may accept an amount of space less than what it originally requested by submitting an application as set forth above, and upon request, may maintain its position on the waiting list for the remaining space that was initially requested. If ComSouth does not submit an application or notify BellSouth in writing within the thirty (30) day timeframe as described in Section 6.7.2 above, BellSouth will offer the available space to the next telecommunications carrier on the waiting list and remove ComSouth from the waiting list. Upon request, BellSouth will advise ComSouth as to its position on the waiting list for a particular BellSouth Premises.
- 6.8 Public Notification. BellSouth will maintain on its Interconnection Web site, a notification document that will indicate all BellSouth Premises that are without available space. BellSouth shall update such document within ten (10) days of the date that BellSouth becomes aware that insufficient space is available to accommodate physical Collocation. BellSouth will also post a document on its Interconnection Web site that contains a general notice when space becomes available in a BellSouth Premises previously on the space exhaust list.
- 6.9 Application Response
- 6.9.1 In Georgia, when space has been determined to be available for physical (caged or cageless) Collocation arrangements, BellSouth will provide an Application Response within twenty (20) days of receipt of a Bona Fide application. The Application Response will be a written response that includes sufficient information to enable ComSouth to place a Firm Order, which, at a minimum, will include the configuration of the space, the Cable Installation Fee, the Cable Records Fee, and any other applicable space preparation fees, as described in Section 8 below.
- 6.10 Application Modifications. If a modification or revision is made to any information in the Bona Fide application after BellSouth has provided the Application Response and prior to a BFFO, with the exception of modifications to (1) Customer Information, (2) Contact Information or (3) Billing Contact Information, whether at the request of ComSouth or as necessitated by technical considerations, the application shall be considered a new application and handled as a new application with respect to the response and provisioning intervals. BellSouth will charge ComSouth the appropriate application fee associated with the level of assessment performed by BellSouth, pursuant to Sections 6.1 and 6.2 above.
- 6.11 Bona Fide Firm Order
- 6.11.1 ComSouth shall indicate its intent to proceed with a Collocation Space request in a BellSouth Premises by submitting a BFFO to BellSouth. The BFFO must be received by BellSouth no later than thirty (30) days after BellSouth's Application Response to ComSouth's Bona Fide application or ComSouth's application will expire.

- 6.11.2 BellSouth will establish a Firm Order date based upon the date BellSouth is in receipt of ComSouth's BFFO. BellSouth will acknowledge the receipt of ComSouth's BFFO within seven (7) days of receipt, so that ComSouth will have positive confirmation that its BFFO has been received. BellSouth's response to a BFFO will include a Firm Order Confirmation, which contains the firm order date. No revisions may be made to a BFFO.

7 Construction and Provisioning

7.1 Construction and Provisioning Intervals

- 7.1.1 In Georgia, BellSouth will complete construction for caged physical Collocation Space under ordinary conditions as soon as possible within a maximum of ninety (90) days from receipt of a BFFO or as agreed to by the Parties. BellSouth will complete construction for cageless physical Collocation Space under ordinary conditions as soon as possible within a maximum of sixty (60) days from receipt of a BFFO and ninety (90) days from receipt of a BFFO for extraordinary conditions, or as agreed to by the Parties. Ordinary conditions are defined as space available with only minor changes required to BellSouth's support systems. (Examples include, but are not limited to: minor modifications to HVAC, cabling and BellSouth's power plant.) Extraordinary conditions include, but may not be limited to: major BellSouth equipment rearrangements or additions; power plant additions or upgrades; major mechanical additions or upgrades; major upgrades for ADA compliance; environmental hazards or hazardous materials abatement; and arrangements for which equipment shipping intervals are extraordinary in length. The Parties may mutually agree to renegotiate an alternative provisioning interval for the Collocation Space requested or BellSouth may seek a waiver from the ordered interval, as set forth above, from the appropriate Commission, if BellSouth does not believe that construction will be completed within the relevant provisioning interval.

- 7.1.2 Records Only Change. When ComSouth adds equipment, that was originally included on ComSouth's Initial Application or a Subsequent Application, and the installation of this equipment requires no additional space preparation work or cable terminations on the part of BellSouth, then BellSouth will impose no additional charges or intervals.

- 7.1.3 For Central Offices in the state of Georgia, BellSouth will provide the reduced intervals outlined below to ComSouth, when ComSouth requests an Alteration specifically identified in Sections 7.1.4.1 through 7.1.4.9 below as an "Augment". Except as otherwise set forth in Section 7.1.4.10 below, such Augment will require a Subsequent Application and will result in the assessment of the appropriate application fee associated with the type of Augment requested by ComSouth. BellSouth will assess the appropriate nonrecurring application fee set forth in Exhibit B on the date that it provides an Application Response to ComSouth.

- 7.1.4.1 Simple Augments will be completed within twenty (20) days after receipt of the

BFFO for an:

- Extension of Existing AC Circuit Capacity within Arrangement where Sufficient Circuit Capacity is Available
- Fuse Change and/or Increase or Decrease -48 Volt (-48V) DC Power

7.1.4.2 Minor Augments will be completed within forty-five (45) days after receipt of the BFFO for:

- 168 DS1 Terminations at the BellSouth Demarcation Frame (Databasing Only; Panels, Relay Racks and Overhead Racking Exist)
- 96 DS3 Terminations at the BellSouth Demarcation Frame (Databasing Only; Panels, Relay Racks and Overhead Racking Exist)
- 99 Fiber terminations at the BellSouth Demarcation Frame (Databasing Only; Panels, Relay Racks and Overhead Racking Exist)
- Maximum of 2000 Service Ready DS0 Terminations at the BellSouth Demarcation Frame (Databasing Only; Panels, Relay Racks and Overhead Racking Exist)

7.1.4.3 Intermediate Augments will be completed within sixty (60) days after receipt of the BFFO for:

- 168 DS1s (Databasing and Installation of Termination Panels, Relay Racks or Additional Structure, as Required)
- 96 DS3s (Databasing and Installation of Termination Panels, Relay Racks or Additional Structure, as Required)
- 99 Fiber Terminations (Databasing and Installation of Termination Panels, Relay Racks or Additional Structure, as Required)
- 2000 DS0s (Databasing and Installation of Termination Panels, Relay Racks or Additional Structure, as Required)
- Installation of Cable Racking or Other Support Structure, as Required, to Support CCXCs (Adequate Floor or Ceiling Structural Capacity Exists and Support/Protection structure for Fiber Patch Cord is Excluded)

7.1.4.4 Major Augments of physical Collocation Space will be completed within ninety (90) days after BFFO. All requests for additional Physical Collocation Space (caged or cageless) are included in this category.

7.1.4.5 Major Augments of virtual Collocation Space will be completed within seventy-five (75) days after BFFO. This category includes all requests for additional virtual Collocation Space.

7.1.4.6 If ComSouth submits an Augment that includes two (2) Augment items from the same category in either Sections 7.1.4.1, 7.1.4.2 or 7.1.4.3 above, the provisioning interval associated with the next highest Augment category will apply (e.g., if two (2) items from the Minor Augment category are requested on the same request, then an interval of sixty (60) days from the receipt of the BFFO would apply, which is the interval associated with the Intermediate Augment category).

- 7.1.4.7 If ComSouth submits an Augment that includes three (3) Augment items from the same category in either Sections 7.1.4.1, 7.1.4.2, or 7.1.4.3 above, the Major Augment interval of ninety (90) days from the receipt of the BFFO would apply (e.g., if three (3) items from the Simple Augment category are requested on the same request for a physical Collocation arrangement, then an interval of ninety (90) days from the receipt of the BFFO would apply, which is the Major physical Augment interval; likewise if three (3) items from the Simple Augment category are requested on the same request for a virtual Collocation arrangement, then an interval of seventy-five (75) days from the receipt of the BFFO would apply, which is the Major virtual Augment interval).
- 7.1.4.8 If ComSouth submits an Augment that includes one (1) Augment item from two (2) separate categories in Sections 7.1.4.1, 7.1.4.2 and 7.1.4.3 above, the Augment interval associated with the highest Augment category will apply (e.g., if an item from the Minor Augment category and an item from the Intermediate Augment category are requested on the same request, then an interval of sixty (60) days from the receipt of the BFFO would apply, which is the interval associated with the Intermediate Augment category).
- 7.1.4.9 All Augments not expressly included in the Simple, Minor, Intermediate or Major Augment categories, as outlined above, will be placed into the appropriate category as negotiated by ComSouth and BellSouth. If ComSouth and BellSouth are unable to determine the appropriate category through negotiation, then the appropriate Major Augment category, identified in Sections 7.1.4.4 and Section 7.1.4.5 above, would apply based on whether the Augment is for ComSouth's physical or virtual Collocation Space.
- 7.1.4.10 Individual application fees associated with Simple, Minor and Intermediate Augments are contained in Exhibit B. If ComSouth requests multiple items from different Augment categories, BellSouth will bill ComSouth the Augment application fee, as identified in Exhibit B, associated with the higher Augment category only. The appropriate application fee will be assessed to ComSouth at the time BellSouth provides ComSouth with the Application Response. ComSouth will be assessed a Subsequent Application Fee for all Major Augments (Major Augments are defined above in Sections 7.1.4.4 and 7.1.4.5 above for physical and virtual Collocation Space, respectively). The Subsequent Application Fee is also reflected in Exhibit B.
- 7.2 Joint Planning. Unless otherwise agreed to by the Parties, a joint planning meeting or other method of joint planning between BellSouth and ComSouth will commence within a maximum of twenty (20) days from BellSouth's receipt of a BFFO. At such meeting, the Parties will agree to the preliminary design of the Collocation Space and the equipment configuration requirements, as reflected in the application and affirmed in the BFFO.
- 7.3 Permits. Each Party, its agent(s) or BellSouth Certified Supplier(s) will diligently pursue filing for the permits required for the scope of work to be performed by

that Party, its agent(s) or BellSouth Certified Supplier(s) within ten (10) days of the completion of the finalized construction design and specifications.

7.4 Central Office Circuit Facility Assignments

7.4.1 Unless otherwise specified, BellSouth will provide Circuit Facility Assignments (CFAs) to ComSouth prior to the applicable provisioning interval set forth herein (Provisioning Interval) for those BellSouth Premises in which ComSouth has physical Collocation Space with no POT bay or with a grandfathered POT bay provided by BellSouth. BellSouth cannot provide CFAs to ComSouth prior to the Provisioning Interval for those BellSouth Premises in which ComSouth has physical Collocation Space with a POT bay provided by ComSouth or virtual Collocation Space, until ComSouth has provided BellSouth with the following information:

7.4.1.1 For physical Central Office Collocation Space with a ComSouth-provided POT bay, ComSouth shall provide BellSouth with a complete layout of the POT panels on an Equipment Inventory Update (EIU) form that shows the locations, speeds, etc.; or

7.4.1.2 For virtual Central Office Collocation Space, ComSouth shall provide BellSouth with a complete layout of ComSouth's equipment on an EIU form, that includes the locations of the low speed ports and the specific frame terminations to which the equipment will be wired by ComSouth's BellSouth Certified Supplier.

7.4.2 BellSouth cannot begin work on the CFAs until the complete and accurate EIU form has been received from ComSouth. If the EIU form is provided within ten (10) days prior to the ending date of the Provisioning Interval, then the CFAs will be made available by the ending date of the Provisioning Interval. If the EIU form is not received ten (10) days prior to the ending date of the Provisioning Interval, then the CFAs will be provided within ten (10) days of BellSouth's receipt of the EIU form.

7.4.3 BellSouth will bill ComSouth a nonrecurring charge, as set forth in Exhibit B, each time ComSouth requests a resend of its original CFA information for any reason other than a BellSouth error in the CFAs initially provided to ComSouth.

7.5 Use of BellSouth Certified Supplier. ComSouth shall select a supplier which has been approved as a BellSouth Certified Supplier to perform all engineering and installation work. ComSouth, if a BellSouth Certified Supplier or ComSouth's BellSouth Certified Supplier must follow and comply with all of BellSouth's specifications and the following BellSouth Technical Requirements: TR 73503, TR 73519, TR 73572 and TR 73564. Unless the BellSouth Certified Supplier has met the requirements for all of the required work activities, ComSouth must use a different BellSouth Certified Supplier for the work activities associated with transmission equipment, switching equipment and power equipment. BellSouth shall provide ComSouth with a list of BellSouth Certified Suppliers, upon request. ComSouth, if a BellSouth Certified Supplier, or ComSouth's BellSouth Certified Supplier(s) shall be responsible for installing ComSouth's equipment and associated components, extending power cabling to the BellSouth power

distribution frame, performing operational tests after installation is complete, and notifying BellSouth's equipment engineers and ComSouth upon successful completion of the installation and any associated work. When a BellSouth Certified Supplier is used by ComSouth, the BellSouth Certified Supplier shall bill ComSouth directly for all work performed for ComSouth pursuant to this Attachment. BellSouth shall have no liability for nor responsibility to pay, such charges imposed by ComSouth's BellSouth Certified Supplier. BellSouth shall make available its supplier certification program to ComSouth or any supplier proposed by ComSouth and will not unreasonably withhold certification. All work performed by or for ComSouth shall conform to generally accepted industry standards.

7.6 Alarms and Monitoring. BellSouth shall place environmental alarms in the BellSouth Premises for the protection of BellSouth equipment and facilities. ComSouth shall be responsible for the placement, monitoring and removal of environmental and equipment alarms used to service ComSouth's Collocation Space. Upon request, BellSouth will provide ComSouth with an applicable BellSouth tariffed service(s) to facilitate remote monitoring of collocated equipment by ComSouth. Both Parties shall use best efforts to notify the other of any verified environmental condition (e.g., temperature extremes or excess humidity) known to that Party.

7.7 Virtual to Physical Relocation. In the event physical Collocation Space was previously denied at a BellSouth Central Office due to technical reasons or space limitations and physical Collocation Space has subsequently become available, ComSouth may relocate its existing virtual Collocation arrangement(s) to a physical Collocation arrangement(s) and pay the appropriate fees associated with the rearrangement or reconfiguration of the services being terminated into the virtual Collocation arrangement, as set forth in Exhibit B. If BellSouth knows when additional physical Collocation Space may become available at the BellSouth Central Office requested by ComSouth, such information will be provided to ComSouth in BellSouth's written denial of physical Collocation Space. ComSouth must arrange with a BellSouth Certified Supplier for the relocation of equipment from a virtual Collocation Space to a physical Collocation Space and will bear the cost of such relocation, including the costs associated with moving the services from the virtual Collocation Space to the new physical Collocation Space.

7.8 Virtual to Physical Conversion (In-Place)

7.8.1 Virtual collocation arrangements in Central Offices may be converted to "in-place" physical caged collocation arrangements if the potential conversion meets all of the following criteria: (1) there is no change in the amount of equipment or the configuration of the equipment that was in the virtual Collocation Space; (2) the conversion of the virtual collocation arrangement will not cause the equipment or the results of that conversion to be located in a space that BellSouth has reserved for its own future needs; and (3) any changes to the arrangement can be accommodated by existing power, HVAC, and other

requirements. Unless otherwise specified herein, BellSouth will complete virtual to physical Collocation Space conversions (in-place) within sixty (60) days from receipt of the BFFO. BellSouth will bill ComSouth an Administrative Only Application Fee, as set forth in Exhibit B, on the date BellSouth provides an Application Response to ComSouth.

7.9 Cancellation. Unless otherwise specified in this Attachment, if at any time prior to Space Acceptance, ComSouth cancels its order for Collocation Space (Cancellation), BellSouth will bill the applicable nonrecurring charge(s) for any and all work processes for which work has begun or been completed. In Georgia, if ComSouth cancels its order for Collocation Space at any time prior to space acceptance, BellSouth will bill ComSouth for all costs incurred prior to the date of Cancellation and for any costs incurred as a direct result of the Cancellation, not to exceed the total amount that would have been due had the Firm Order not been canceled.

7.10 Licenses. ComSouth, at its own expense, will be solely responsible for obtaining from governmental authorities, and any other appropriate agency, entity, or person, all rights, privileges, permits, licenses and certificates necessary or required to operate as a provider of telecommunications services to the public or to build-out, equip and/or occupy Collocation Space in a BellSouth Premises.

7.11 Environmental Compliance. The Parties agree to utilize and adhere to the Environmental Hazard Guidelines identified in Exhibit A attached hereto.

8 Rates and Charges

8.1 Rates. ComSouth agrees to pay the rates and charges identified in Exhibit B attached hereto.

8.2 Application Fees. BellSouth shall assess any nonrecurring application fees within thirty (30) days of the date that BellSouth provides an Application Response to ComSouth or on ComSouth's next scheduled monthly billing statement.

8.3 Recurring Charges

8.3.1 If ComSouth has met the applicable fifteen (15) day acceptance walk through interval specified in Section 4.2 above, billing for recurring charges will begin upon the Space Acceptance Date. In the event ComSouth fails to complete an acceptance walk through within the applicable fifteen (15) day interval, billing for recurring charges will commence on the Space Ready Date. If ComSouth occupies the space prior to the Space Ready Date, the date ComSouth occupies the space is deemed the Space Acceptance Date and billing for recurring charges will begin on that date. The billing for all applicable monthly recurring charges will begin in ComSouth's next billing cycle and will include any prorated charges for the period from ComSouth's Space Acceptance Date or Space Ready Date, whichever is appropriate pursuant to Section 4.2 above, to the date the bill is issued by BellSouth.

8.3.2 Unless otherwise stated in Section 8.6 below, monthly recurring charges for -48V

DC power will be assessed per fused ampere (amp), per month, based upon the total number of fused amps of power capacity requested by ComSouth on ComSouth's Initial Collocation Application and all Subsequent Collocation Applications, which may either increase or decrease the originally requested, and any subsequently augmented, number of fused amps of power capacity requested, consistent with Commission orders.

- 8.3.3 BellSouth shall have the right to inspect and inventory any DC power fuse installations at a BellSouth BDFB or DC power circuit installations at BellSouth's main power board for any ComSouth collocation arrangement, to verify that the total number of fused amps of power capacity installed by ComSouth's BellSouth Certified Supplier matches the number of fused amps of DC power capacity requested by ComSouth on ComSouth's Initial Application and all Subsequent Applications. If BellSouth determines that ComSouth's BellSouth Certified Supplier has installed more DC capacity than ComSouth requested on its Initial Application and all Subsequent Applications, BellSouth shall notify ComSouth in writing of such discrepancy and shall assess ComSouth for the additional DC power fuse/circuit capacity from the Space Acceptance Date or Space Ready Date, whichever is applicable pursuant to Section 8.3.1 above, for the most recent Initial Application or Subsequent Application, submitted for such collocation arrangement. BellSouth shall also revise ComSouth's recurring DC power charges, on a going-forward basis, to reflect the higher number of fused amps of power capacity available for the collocation arrangement.
- 8.4 Nonrecurring Charges. Unless specified otherwise herein, BellSouth shall assess nonrecurring charges, including all application fees, within thirty (30) days of the date that BellSouth provides an Application Response to ComSouth or on ComSouth's next scheduled monthly billing statement, if ComSouth's current month's billing cycle has already closed. Nonrecurring charges associated with the processing of the Firm Order for collocation space preparation (Firm Order Processing Fee) shall be billed by BellSouth within thirty (30) days of BellSouth's confirmation of ComSouth's BFFO or on ComSouth's next scheduled monthly billing statement.
- 8.5 In some cases, Commissions have ordered BellSouth to separate its disconnect costs and its installation costs into two separate nonrecurring charges. Accordingly, unless otherwise noted in this Agreement, the Commission ordered disconnect charges will be applied at the time the disconnect activity is performed by BellSouth, regardless of whether or not a disconnect order is issued by ComSouth. Disconnect charges are set forth in Exhibit B of this Attachment.
- 8.6 Central Office Space Preparation. Space preparation fees consist of a nonrecurring charge for Firm Order Processing and monthly recurring charges for Central Office Modifications and Common Systems Modifications. ComSouth shall remit the payment of the nonrecurring Firm Order Processing Fee coincident with the submission of ComSouth's BFFO. The monthly recurring charge for Central Office Modifications will be assessed per arrangement, per square foot, for both caged and cageless physical Collocation Space. The monthly recurring

charge for Common Systems Modifications will be assessed per arrangement, per square foot for cageless physical Collocation Space and on a per cage basis for caged physical Collocation Space. These charges recover the costs associated with preparing the Collocation Space, which includes, but is not limited to, the following items: a survey, engineering of the Collocation Space, and design and modification costs for network, building and support systems.

- 8.7 Central Office Floor Space. The Floor Space Charge includes reasonable charges for lighting, HVAC, and other allocated expenses associated with maintenance of the BellSouth Premises; however, this charge does not include any expenses associated with AC or DC power supplied to ComSouth's Collocation Space for the operation of ComSouth's equipment. For caged physical Collocation Space, ComSouth shall pay floor space charges based upon the number of square feet enclosed. The minimum size for caged Collocation Space is fifty (50) square feet. Additional caged Collocation Space may be requested in increments of fifty (50) square feet. For cageless Collocation Space, ComSouth shall pay floor space charges based upon the following floor space calculation: [(depth of the equipment lineup in which the rack is placed) + (0.5 x maintenance aisle depth) + (0.5 x wiring aisle depth)] x (width of rack and spacers). For purposes of this calculation, the depth of the equipment lineup shall consider the footprint of equipment racks plus any equipment overhang. BellSouth will assign cageless Collocation Space in conventional equipment rack lineups where feasible. In the event ComSouth's collocated equipment requires special cable racking, an isolated ground plane, or any other considerations and treatment which prevents placement within conventional equipment rack lineups, ComSouth shall be required to request an amount of floor space sufficient to accommodate the total equipment arrangement.
- 8.8 Remote Site Bay Space. In a Remote Site, the bay space charge recovers the costs associated with air conditioning, ventilation and other allocated expenses for the maintenance of the Remote Site Location, and includes the amperage necessary to power ComSouth's equipment. ComSouth shall remit bay space charges based upon the number of bays requested. BellSouth will assign Remote Site Collocation Space in conventional Remote Site bay lineups where feasible.
- 8.9 Power
- 8.9.1 In a Central Office BellSouth shall make available -48V DC power for ComSouth's Collocation Space at a BellSouth BDFB. When obtaining DC power from a BellSouth BDFB, ComSouth's fuses and power cables (for the A & B feeds) must be engineered (sized), and installed by ComSouth's BellSouth Certified Supplier, in accordance with the number of fused amps of DC power requested by ComSouth on ComSouth's Initial Application and any Subsequent Applications. ComSouth is also responsible for contracting with a BellSouth Certified Supplier to run the power distribution feeder cable from the BellSouth BDFB to the equipment in ComSouth's Collocation Space. The BellSouth Certified Supplier contracted by ComSouth must provide BellSouth with a copy of the engineering power specifications prior to the day on which ComSouth's

equipment becomes operational (hereinafter “Commencement Date”). BellSouth will provide the common power feeder cable support structure between the BellSouth BDFB and ComSouth’s Collocation Space. ComSouth shall contract with a BellSouth Certified Supplier who shall be responsible for performing those power provisioning activities required to enable ComSouth’s equipment to become operational, which may include, but are not limited to, the installation, removal or replacement of the following: dedicated power cable support structure within ComSouth’s Collocation Space, power cable feeds and terminations of the power cabling. ComSouth and ComSouth’s BellSouth Certified Supplier shall comply with all applicable NEC, BellSouth TR 73503, Telcordia and ANSI Standards that address power cabling, installation and maintenance.

- 8.9.1.1 At a Remote Site, BellSouth shall make available -48V DC power for ComSouth’s Remote Collocation Space at a BDFB within the Remote Site Location. The charge for power shall be assessed as part of the recurring charge for bay space, as referenced in Section 8.7 above. If the power requirements for ComSouth’s equipment exceed the capacity available, then such additional power requirements shall be assessed on an individual case basis.
- 8.9.2 BellSouth will revise ComSouth’s Central Office recurring power charges, in accordance with Section 8.3 above, to reflect a power upgrade when ComSouth submits a Subsequent Application requesting an increase in the number of fused amps it is currently receiving from BellSouth for its Collocation Space. If ComSouth’s existing fuses and power cables (for the A&B power feed) are not sufficient to support the additional number of fused amps requested, ComSouth’s BellSouth Certified Supplier shall perform whatever activities are necessary, which may include the installation of new/additional fuses or power cables, to comply with the appropriate NEC, BellSouth TR 73503, Telcordia and ANSI Standards, as well as the requirements noted in Sections 8.7 and 8.7.1 above. ComSouth’s BellSouth Certified Supplier shall provide notification to BellSouth when these activities have been completed.
- 8.9.3 BellSouth will revise ComSouth’s Central Office recurring power charges, in accordance with Section 8.3 above, to reflect a power reduction upon BellSouth’s receipt of the Power Reduction Form from ComSouth, certifying the completion of the power reduction work, including the removal of any associated power cabling by ComSouth’s BellSouth Certified Supplier. Notwithstanding the foregoing, if ComSouth’s BellSouth Certified Supplier has not removed or, at BellSouth’s discretion, cut the power cabling within thirty (30) days, the power reduction will not become effective until the cabling is removed or, at BellSouth’s discretion, cut by ComSouth’s BellSouth Certified Supplier and ComSouth shall pay for the amount of power that had been requested prior to the power reduction request for the period up to the date the power cabling is actually removed.
- 8.9.4 If ComSouth requests an increase or a reduction in the amount of power that BellSouth is currently providing in a Central Office, ComSouth must submit a Subsequent Application. If no modification to the Collocation Space is requested other than the increase or reduction in power, the Simple Augment fee will apply.

If modifications are requested in addition to the increase or reduction of power, the Subsequent Application Fee will apply. BellSouth will bill this nonrecurring fee on the date that BellSouth provides an Application Response to ComSouth's Subsequent Application.

- 8.9.5 If ComSouth elects to install its own DC Power Plant, BellSouth shall provide AC power to feed ComSouth's DC Power Plant. Charges for AC power will be assessed on a per breaker ampere, per month basis, pursuant to the rates specified in Exhibit B. The AC power rates include recovery for the provision of commercial and standby AC power. When obtaining power from a BellSouth service panel, protection devices and power cables must be engineered (sized) and installed by ComSouth's BellSouth Certified Supplier, with the exception that BellSouth shall engineer and install protection devices and power cables for Adjacent Collocation. ComSouth's BellSouth Certified Supplier must provide a copy of the engineering power specifications prior to the Commencement Date. AC power voltage and phase ratings shall be determined on a per location basis. At ComSouth's option, ComSouth may arrange for AC power in an adjacent collocation arrangement from a retail provider of electrical power.
- 8.9.6 ComSouth shall contract with a BellSouth Certified Supplier to perform the installation and removal of dedicated power cable support structure within ComSouth's arrangement and terminations of cable within the Collocation Space.
- 8.9.7 Fused Amp Power. In all states, except as otherwise set forth in this Agreement, BellSouth shall make available -48V DC power on a per fused amp, per month basis, pursuant to the following:
- For power provisioned from a BDFB. The number of fused amps requested by ComSouth on its collocation application for power that is being provisioned from a BellSouth BDFB will be multiplied by the DC power fused amp rate set forth in Exhibit B. A minimum of ten (10) fused amps is required.
- For existing power configurations that are provisioned from BellSouth's main power board. The number of fused amps made available at the main power board, in increments of two hundred and twenty-five (225) amps/main power board circuit, will be multiplied by the DC power fused amp rate set forth in Exhibit B.
- 8.9.9 Georgia Caged Collocation Power Usage Metering Option. - In Georgia, ComSouth may request that DC power provisioned by BellSouth to ComSouth's Collocation Space be assessed pursuant to Georgia Public Service Commission Order Docket No. 14361-U ("Order"). BellSouth will assess ComSouth for -48V DC power using the actual number of load Amps measured. The power circuits may be fed from either a BellSouth BDFB or ComSouth's BDFB. These recurring power charges will be assessed by BellSouth on the Space Acceptance Date or Space Ready Date, whichever is appropriate, pursuant to Section 8.3.
- 8.9.11.1 Upon ComSouth's election of the power metering option ComSouth will convert existing caged collocation arrangements to the power metering rate structure. The

recurring power charges that are contained Exhibit B of this Attachment will be assessed on the Space Ready Date associated with the Subsequent Application submitted by ComSouth to convert an existing caged collocation arrangement to the metered power rates.

- 8.9.11.2 Pursuant to the Order, ComSouth shall provide a Fluke Model 189 AC/DC multimeter and Fluke Model i410 clamp-on ammeter probe for each central office where they have requested metered power. One copy of the FlukeView software must also be provided for each Fluke 189 multimeter, and each copy must comply with Fluke copyrights.
- 8.9.11.3 ComSouth may, at its sole cost and expense, install its own meters on its BDFB(s) located in its own caged Collocation Space(s) and notify BellSouth of the option of using such meters for the purposes of measuring ComSouth's actual power usage. In such case, BellSouth, or its BellSouth Certified Supplier, will have the option of reading and recording the actual power usage from either the meter installed on ComSouth's own BDFB(s) or via the aforementioned Fluke 189 multimeter equipped with a Fluke i410 clamp-on ammeter probe.
- 8.9.11.4 BellSouth, at its sole option and at its own cost, may choose to purchase, install, and use its own ammeter measurement device. The usage reading for the option elected by BellSouth shall be used for purposes of calculating the DC power usage billing.
- 8.9.11.5 BellSouth, or its BellSouth Certified Supplier, will perform all metering activities, to measure the actual power usage being drawn by ComSouth's collocation equipment on both the A and B power feeds. The charge will be the sum of both the A and B power feeds and will be based upon either an instantaneous reading or busy hour average current reading, depending on the capabilities of the ammeter measurement device.
- 8.9.11.6 If BellSouth, or its BellSouth Certified Supplier, requires access to ComSouth's caged Collocation Space(s) for purposes of measuring the power usage, BellSouth or its BellSouth Certified Supplier shall provide ComSouth with a minimum of forty-eight (48) hours (two business days) notice that access is required. ComSouth shall respond to such request for access within twenty-four (24) hours for the purpose of establishing the date and time of access to ComSouth's caged Collocation Space(s). Once the date and time of access to ComSouth's caged Collocation Space(s) has been agreed upon, ComSouth and BellSouth, or its BellSouth Certified Supplier, shall adhere to the agreed upon date and time, or provide a minimum of three (3) hours notice to the other Party if the original appointment(s) will be missed or must be canceled and rescheduled. Once a mutually agreed upon date and time are established and ComSouth does not provide minimum of three (3) hours notice, BellSouth's Certified Supplier will only remain at the site for thirty (30) minutes. After thirty (30) minutes the appointment will be considered missed by ComSouth.
- 8.9.11.7 If ComSouth fails to provide access to its caged Collocation Space(s) or fails to provide BellSouth, or its BellSouth Certified Supplier, with sufficient notification

of the missed appointment(s), as noted above, then ComSouth shall pay the nonrecurring “Additional Meter Reading Trip Charge”, as set forth in Exhibit B of this Attachment, for each additional meter reading trip that must be rescheduled to measure ComSouth’s power usage for such caged Collocation Space(s). ComSouth and the BellSouth Certified Supplier may jointly agree to less stringent notification requirements to address, for example, any service interruption or restoration of service situations, on a location-by-location basis.

- 8.9.11.8 For each new caged collocation arrangement, ComSouth shall indicate on ComSouth’s Initial Application that they are electing to have metered power. For each location that ComSouth wishes to convert to metered power ComSouth will submit a Subsequent Application and agrees to include in the Comments section of the Subsequent Application the following comment:

This Subsequent Application is ComSouth’s certification that ComSouth is opting to convert this caged collocation arrangement to metered power and will permit BellSouth, or the BellSouth Certified Supplier, to measure its actual power usage on all power feeds.

- 8.9.11.9 BellSouth will bill ComSouth a Power Reconfiguration Only Application Fee, as set forth in Exhibit B of this Attachment, on the date that BellSouth provides an Application Response to each Subsequent Application submitted by ComSouth converting its caged collocation arrangements to the metered power rates. BellSouth shall then arrange for the measurement of ComSouth’s actual power usage on each power feed (each A and B power feed) once each quarter at each of ComSouth’s caged collocation arrangements for which ComSouth has submitted an Initial or Subsequent Application electing metered power.

- 8.9.11.10 Based upon the actual power usage measurement taken by BellSouth or the BellSouth Certified Supplier, BellSouth shall assess ComSouth for power usage for the following quarter based upon ComSouth’s actual metered usage for each power feed (both the A and B power feeds) or a minimum of ten (10) amps of – 48V DC power usage for the sum of the A and B feeds for each power cable, whichever is greater. Such usage shall then be multiplied by the rate for Load Amps either with a BellSouth BDFB or with ComSouth BDFB as set forth in Exhibit B of this Attachment, to determine the appropriate monthly recurring power usage charge that will be billed to ComSouth for the following three (3) months or until the next power usage measurement is taken, whichever is later.

- 8.9.11.11 Either Party, within fifteen (15) days of notice of the usage measurement established by the scheduled meter reading, may challenge the accuracy of that reading by requesting a new reading. If ComSouth requests that an unscheduled (prior to the next scheduled quarterly power reading date) power usage reading be taken, then ComSouth will be responsible for paying the “Additional Meter Reading Trip Charge” contained in Exhibit B of this Attachment. If BellSouth requests a power usage reading be taken in this instance, then ComSouth will not be charged the “Additional Meter Reading Trip Charge” for the unscheduled

meter reading. If the readings vary by more than ten (10) % or five (5) Amps, whichever is greater, the Parties shall work cooperatively to reconcile such discrepancies and establish the appropriate usage figure in a reasonable and expeditious manner. If the readings do not vary outside these ranges, the initial reading will be used to calculate ComSouth's AC usage charge for the next three (3) months.

- 8.9.11.12 BellSouth, at any time and at its own expense, shall have the right to verify the accuracy of ComSouth's BDFB meter by performing its own meter reading via an alternate method, such as, but not limited to, an ammeter. If the meter readings vary by more than ten (10) % or five (5) Amps, whichever is greater, the Parties agree to perform a joint investigation. If ComSouth's BDFB meter is found to be in error, then ComSouth agrees to recalibrate, repair, or replace its meter as required. The Parties recognize that the meter readings discussed in this Attachment are instantaneous readings that can experience minor fluctuations due to usage traffic, voltage fluctuations, and calibration of the meters themselves. The readings must vary by more than ten (10) % or five (5) Amps, whichever is greater, before any recalibration, repair, or replacement will be required. If the BellSouth reading is substantiated, BellSouth shall adjust ComSouth's billing retroactive to the beginning of the quarter for which the last meter reading was taken.
- 8.9.11.13 When ComSouth submits the appropriate Initial or Subsequent Application for a specific caged collocation arrangement in a particular BellSouth Premises, BellSouth will provide the associated Application Response pursuant to Section 6 above. It will then be the responsibility of ComSouth to submit a BFFO. After BellSouth receives the BFFO from ComSouth, the Initial or Subsequent Application will be completed by BellSouth within the provisioning intervals contained in Section 7 above and ComSouth will be notified of the Space Ready Date or when the appropriate record and database changes have been made by BellSouth to reflect ComSouth's conversion to the metered power rates (which will be considered the "Space Ready Date" for purposes of a Subsequent Application submitted to convert a specific caged collocation arrangement in a particular BellSouth Premises to the metered power rates).
- 8.9.11.14 BellSouth will not permit ComSouth to elect an earlier Space Acceptance Date than the Space Ready Date for any request submitted via a Subsequent Application for an existing caged collocation arrangement. When a Subsequent Application is used to elect metered power and there are no other changes requested, billing for the recurring charges associated with metered power will begin upon the Space Ready Date. If ComSouth occupies the space prior to the Space Ready Date, for Initial Application requests only, the date ComSouth occupies the space will be deemed the new Space Acceptance Date and billing for metered power will begin on that date. When ComSouth moves to metered power the number of fused amps of DC Power requested by ComSouth on its Initial or Subsequent Application will be used for calculating the number of amps to be billed until such time as BellSouth or its BellSouth Certified Supplier can

perform, under the currently existing quarterly meter reading schedule, a reading of ComSouth's power usage for the requested caged Collocation Space. As soon as this reading has been taken, BellSouth will adjust ComSouth's billing accordingly to reflect the actual metered usage back to the Space Acceptance Date. BellSouth will also use this reading for billing purposes until the next quarterly meter reading is performed by BellSouth or its BellSouth Certified Supplier.

- 8.9.11.15 ComSouth agrees to submit a Subsequent Application to notify BellSouth when ComSouth has removed or installed telecommunications equipment in ComSouth's physical Collocation Space to ensure that ComSouth's existing fused DC power capacity is sufficiently engineered to accommodate the power requirements associated with the installation of additional equipment in ComSouth's Collocation Space. An associated change in power usage will be reflected in the next quarterly power measurement billing cycle.
- 8.9.11.16 BellSouth will bill ComSouth a monthly recurring charge per caged Collocation Space for each arrangement that ComSouth has converted to metered power or for new caged Collocation Spaces under the election of metered power. This "Meter Reading" monthly recurring rate element will be assessed per circuit for each circuit read by BellSouth or its BellSouth Certified Supplier, at the rates set forth in Exhibit B.
- 8.10 Central Office Cable Installation. Cable Installation fees will be assessed on a per entrance cable basis. This nonrecurring charge will be billed by BellSouth upon receipt of ComSouth's BFFO. Charges for cable racking, cable support structure and entrance fiber structure are recurring fees and will also be assessed according to the rates set forth in Exhibit B.
- 8.11 Central Office Cable Records. Cable Records charges apply for work activities required to build or remove existing cable records assigned to ComSouth in BellSouth's database systems. The VG/DS0 per cable record charge is for a maximum of thirty-six hundred (3,600) records per request. The fiber cable record charge is for a maximum of ninety-nine (99) records per request. Cable Record fees will be assessed as a nonrecurring charge, upon receipt of ComSouth's BFFO, in all BellSouth states. All charges will be assessed the rates set forth in Exhibit B.
- 8.12 Security Escort. After ComSouth has used its one (1) accompanied site visit, pursuant to Section 5.12.1 above, and prior to ComSouth's completion of the BellSouth Security Training requirements, contained in Section 12 below, a security escort will be required when ComSouth's employees, approved agent, supplier, or Guest(s) desire access to the entrance manhole or a BellSouth Premises. The rates for security escort service are assessed pursuant to the fee schedule contained in Exhibit B, beginning with the scheduled escort time agreed to by the Parties. BellSouth will wait for one-half (1/2) hour after the scheduled escort time to provide such requested escort service and ComSouth shall pay for such half-hour charges in the event ComSouth's employees, approved agent,

supplier or Guest(s) fails to show up for the scheduled escort appointment.

- 8.13 Other. If no collocation rate element and associated rate is identified in Exhibit B, the Parties, upon request by either Party, will negotiate the rate for the specific collocation service or function identified in this Attachment.

9 Insurance

- 9.1 ComSouth shall, at its sole cost and expense, procure, maintain, and keep in force insurance as specified in this Section and underwritten by insurance companies licensed to do business in the states applicable under this Agreement and having a Best's Insurance Rating of A.

- 9.2 ComSouth shall maintain the following specific coverage:

- 9.2.1 Commercial General Liability coverage in the amount of ten million dollars (\$10,000,000) or a combination of Commercial General Liability and Excess/Umbrella coverage totaling not less than ten million dollars (\$10,000,000). BellSouth shall be named as an Additional Insured on the Commercial General Liability policy as specified herein.

- 9.2.2 Statutory Workers Compensation coverage and Employers Liability coverage in the amount of one hundred thousand dollars (\$100,000) each accident, one hundred thousand dollars (\$100,000) each employee by disease, and five hundred thousand dollars (\$500,000) policy limit by disease.

- 9.2.3 All Risk Property coverage on a full replacement cost basis insuring all of ComSouth's real and personal property situated on or within a BellSouth Premises.

- 9.2.4 ComSouth may elect to purchase business interruption and contingent business interruption insurance, having been advised that BellSouth assumes no liability for loss of profit or revenues should an interruption of service occur.

- 9.3 The limits set forth in Section 9.2 above may be increased by BellSouth from time to time during the term of this Agreement, upon thirty (30) days notice to ComSouth, to at least such minimum limits as shall then be customary with respect to comparable occupancy of BellSouth structures.

- 9.4 All policies purchased by ComSouth shall be deemed to be primary and not contributing to or in excess of any similar coverage purchased by BellSouth. All insurance must be in effect on or before the date equipment is delivered to BellSouth's Premises and shall remain in effect for the term of this Agreement or until all of ComSouth's property has been removed from BellSouth's Premises, whichever period is longer. If ComSouth fails to maintain required coverage, BellSouth may pay the premiums thereon and seek reimbursement of same from ComSouth.

- 9.5 ComSouth shall submit certificates of insurance reflecting the coverage required pursuant to this Section within a minimum of ten (10) business days prior to the commencement of any work in the Collocation Space. Failure to meet this

interval may result in construction and equipment installation delays. ComSouth shall arrange for BellSouth to receive thirty (30) business days' advance notice of cancellation or non-renewal from ComSouth's insurance company. ComSouth shall forward a certificate of insurance and notice of cancellation/non-renewal to BellSouth at the following address:

BellSouth Telecommunications, Inc.
Attn: Risk Management Office – Finance
17F54 BellSouth Center
675 W. Peachtree Street
Atlanta, GA 30375

9.6 ComSouth must conform to recommendations made by BellSouth's fire insurance company to the extent BellSouth has agreed to, or shall hereafter agree to, such recommendations.

9.7 Self Insurance. If ComSouth's net worth exceeds five hundred million dollars (\$500,000,000), ComSouth may elect to request self-insurance status in lieu of obtaining any of the insurance required in Section 9.2 above. ComSouth shall provide audited financial statements to BellSouth thirty (30) days prior to the commencement of any work in the Collocation Space. BellSouth shall then review such audited financial statements and respond in writing to ComSouth in the event that self-insurance status is not granted to ComSouth. If BellSouth approves ComSouth for self-insurance, ComSouth shall annually furnish to BellSouth, and keep current, evidence of such net worth that is attested to by one of ComSouth's corporate officers. The ability to self-insure shall continue so long as ComSouth meets all of the requirements of this Section. If ComSouth subsequently no longer satisfies the requirements of this Section, ComSouth is required to purchase insurance as indicated by Section 9.2 above.

9.8 The net worth requirements set forth in Section 9.7 above may be increased by BellSouth from time to time during the term of this Agreement upon thirty (30) days' notice to ComSouth to at least such minimum limits as shall then be customary with respect to comparable occupancy of a BellSouth Premises.

9.9 Failure to comply with the provisions of this Section will be deemed a material breach of this Attachment.

10 Mechanics Lien

10.1 If any mechanics lien or other liens are filed against property of either Party (BellSouth or ComSouth), or any improvement thereon by reason of or arising out of any labor or materials furnished or alleged to have been furnished or to be furnished to or for the other Party or by reason of any changes, or additions to said property made at the request or under the direction of the other Party, the other Party directing or requesting those changes shall, within thirty (30) business days after receipt of written notice from the Party against whose property said lien has been filed, either pay such lien or cause the same to be bonded off the affected property in the manner provided by law. The Party causing said lien to be placed against the property of the other shall also defend at its sole cost and expense, on

behalf of the other, any action, suit or proceeding which may be brought for the enforcement of such liens and shall pay any damage and discharge any judgment entered thereon.

11 Inspections

- 11.1 BellSouth may conduct an inspection of ComSouth's equipment and facilities in ComSouth's Collocation Space(s) prior to the activation of facilities and/or services between ComSouth's equipment and equipment of BellSouth. BellSouth may conduct an inspection if ComSouth adds equipment and may otherwise conduct routine inspections at reasonable intervals mutually agreed upon by the Parties. BellSouth shall provide ComSouth with a minimum of forty-eight (48) hours or two (2) business days, whichever is greater, advance notice of all such inspections. All costs of such inspections shall be borne by BellSouth.

12 Security and Safety Requirements

- 12.1 Unless otherwise specified, ComSouth will be required, at its own expense, to conduct a statewide investigation of criminal history records for each ComSouth employee hired in the past five (5) years being considered for work on a BellSouth Premises, for the states/counties where the ComSouth employee has worked and lived for the past five (5) years. Where state law does not permit statewide collection or reporting, an investigation of the applicable counties is acceptable. ComSouth shall not be required to perform this investigation if an affiliated company of ComSouth has performed an investigation of the ComSouth employee seeking access, if such investigation meets the criteria set forth above. This requirement will not apply if ComSouth has performed a pre-employment statewide investigation of criminal history records of the ComSouth employee for the states/counties where the ComSouth employee has worked and lived for the past five (5) years or, where state law does not permit a statewide investigation, an investigation of the applicable counties.
- 12.2 ComSouth will be required to administer to its personnel assigned to the BellSouth Premises security training either provided by BellSouth, or meeting criteria defined by BellSouth at BellSouth's Interconnection Web site, www.interconnection.bellsouth.com/guides.
- 12.3 ComSouth shall provide its employees and agents with picture identification, which must be worn and visible at all times while in ComSouth's Collocation Space or other areas in or around the BellSouth Premises. The photo identification card shall bear, at a minimum, the employee's name and photo and ComSouth's name. BellSouth reserves the right to remove from a BellSouth Premises any employee of ComSouth not possessing identification issued by ComSouth or who has violated any of BellSouth's policies as outlined in the CLEC Security Training documents. ComSouth shall hold BellSouth harmless for any damages resulting from such removal of ComSouth's personnel from a BellSouth Premises. ComSouth shall be solely responsible for ensuring that any Guest(s) of ComSouth is in compliance with all subsections of this Section.
- 12.4 ComSouth shall not assign to the BellSouth Premises any personnel with records

of felony criminal convictions. ComSouth shall not assign to the BellSouth Premises any personnel with records of misdemeanor convictions, except for misdemeanor traffic violations, without advising BellSouth of the nature and gravity of the offense(s). BellSouth reserves the right to refuse building access to any of ComSouth's personnel who have been identified to have misdemeanor criminal convictions. Notwithstanding the foregoing, in the event ComSouth chooses not to advise BellSouth of the nature and gravity of any misdemeanor conviction, ComSouth may, in the alternative, certify to BellSouth that it shall not assign to the BellSouth Premises any personnel with records of misdemeanor convictions (other than misdemeanor traffic violations).

- 12.4.1 ComSouth shall not knowingly assign to the BellSouth Premises any individual who was a former employee of BellSouth and whose employment with BellSouth was terminated for a criminal offense, whether or not BellSouth sought prosecution of the individual for the criminal offense.
- 12.4.2 ComSouth shall not knowingly assign to the BellSouth Premises any individual who was a former supplier of BellSouth and whose access to a BellSouth Premises was revoked due to the commission of a criminal offense, whether or not BellSouth sought prosecution of the individual for the criminal offense.
- 12.5 For each ComSouth employee or agent hired by ComSouth within the last five (5) years, who requires access to a BellSouth Premises to perform work in ComSouth Collocation Space(s), ComSouth shall furnish BellSouth certification that the aforementioned background check and security training were completed. This certification must be provided to and approved by BellSouth before an employee or agent will be granted such access to a BellSouth Premises. The certification will contain a statement that no felony convictions were found and certify that the employee completed the security training. If the employee's criminal history includes misdemeanor convictions, ComSouth will disclose the nature of the convictions to BellSouth at that time. In the alternative, ComSouth may certify to BellSouth that it shall not assign to the BellSouth Premises any personnel with records of misdemeanor convictions, other than misdemeanor traffic violations.
 - 12.5.1 For all other ComSouth employees requiring access to a BellSouth Premises pursuant to this Attachment, ComSouth shall furnish BellSouth, prior to an employee gaining such access, a certification that the employee is not subject to the requirements of Section 12.5 above and that security training was completed by the employee.
- 12.6 At BellSouth's request, ComSouth shall promptly remove from the BellSouth Premises any employee of ComSouth that BellSouth does not wish to grant access to a BellSouth Premises: 1) pursuant to any investigation conducted by BellSouth, or 2) prior to the initiation of an investigation if an employee of ComSouth is found interfering with the property or personnel of BellSouth or another collocated telecommunications carrier, provided that an investigation shall be promptly commenced by BellSouth.
- 12.7 Security Violations. BellSouth reserves the right to interview ComSouth's

employees, agents, suppliers, or Guests in the event of wrongdoing in or around a BellSouth Premises or involving BellSouth's or another collocated telecommunications carrier's property or personnel, provided that BellSouth shall provide reasonable notice to ComSouth's Security representative of such interview. ComSouth and its employees, agents, suppliers, or Guests shall reasonably cooperate with BellSouth's investigation into allegations of wrongdoing or criminal conduct committed by, witnessed by, or involving ComSouth's employees, agents, suppliers, or Guests. Additionally, BellSouth reserves the right to bill ComSouth for all reasonable costs associated with investigations involving its employees, agents, suppliers, or Guests if it is established and mutually agreed in good faith that ComSouth's employees, agents, suppliers, or Guests are responsible for the alleged act(s). BellSouth shall bill ComSouth for BellSouth property, which is stolen or damaged, where an investigation determines the culpability of ComSouth's employees, agents, suppliers, or Guests and where ComSouth agrees, in good faith, with the results of such investigation. ComSouth shall notify BellSouth in writing immediately in the event that ComSouth discovers one of its employees, agents, suppliers, or Guests already working on the BellSouth Premises is a possible security risk. Upon request of the other Party, the Party who is the employer shall discipline consistent with its employment practices, up to and including removal from BellSouth's Premises, any employee found to have violated the security and safety requirements of this Section. ComSouth shall hold BellSouth harmless for any damages resulting from such removal of ComSouth's personnel from a BellSouth Premises.

- 12.8 Use of Supplies. Unauthorized use of equipment, supplies or other property by either Party, whether or not used routinely to provide telephone service will be strictly prohibited and handled appropriately. Costs associated with such unauthorized use may be charged to the offending Party, as may be all associated investigative costs.
- 12.9 Use of Official Lines. Except for non-toll calls necessary in the performance of their work, neither Party shall use the telephone(s) of the other Party on BellSouth's Premises. Charges for unauthorized telephone calls may be charged to the offending Party, as may be all associated investigative costs.
- 12.10 Accountability. Full compliance with the Security requirements of this Section shall in no way limit the accountability of either Party to the other for the improper actions of its employees, agents, suppliers, or Guests.

13 Destruction of Collocation Space

- 13.1 In the event a Collocation Space is wholly or partially damaged by fire, windstorm, hurricane, tornado, flood or by similar force majeure circumstances to such an extent as to be rendered wholly unsuitable for ComSouth's permitted use hereunder, then either Party may elect within ten (10) days after such damage, to terminate occupancy of the damaged Collocation Space, and if either Party shall so elect, by giving the other written notice of termination, both Parties shall stand

released of and from further liability under the terms hereof. If the Collocation Space shall suffer only minor damage and shall not be rendered wholly unsuitable for ComSouth's permitted use, or is damaged and the option to terminate is not exercised by either Party, BellSouth covenants and agrees to proceed promptly without expense to ComSouth, except for improvements not to the property of BellSouth, to repair the damage. BellSouth shall have a reasonable time within which to rebuild or make any repairs, and such rebuilding and repairing shall be subject to delays caused by storms, shortages of labor and materials, government regulations, strikes, walkouts, and causes beyond the control of BellSouth, which causes shall not be construed as limiting factors, but as exemplary only. ComSouth may, at its own expense, accelerate the rebuild of its Collocation Space and equipment provided, however, that a BellSouth Certified Supplier is used and the necessary space preparation has been completed. If ComSouth's acceleration of the project increases the cost of the project, then those additional charges will be incurred at ComSouth's expense. Where allowed and where practical, ComSouth may erect a temporary facility while BellSouth rebuilds or makes repairs. In all cases where the Collocation Space shall be rebuilt or repaired, ComSouth shall be entitled to an equitable abatement of rent and other charges, depending upon the unsuitability of the Collocation Space for ComSouth's permitted use, until such Collocation Space is fully repaired and restored and ComSouth's equipment installed therein (but in no event later than thirty (30) days after the Collocation Space is fully repaired and restored). Where ComSouth has placed an Adjacent Arrangement pursuant to Section 3.4 above, ComSouth shall have the sole responsibility to repair or replace said Adjacent Arrangement provided herein. Pursuant to this Section, BellSouth will restore the associated services to the Adjacent Arrangement.

14 Eminent Domain

- 14.1 If the whole of a Collocation Space or Adjacent Arrangement shall be taken by any public authority under the power of eminent domain, then this Attachment shall terminate with respect to such Collocation Space or Adjacent Arrangement as of the date possession shall be taken by such public authority and rent and other charges for the Collocation Space or Adjacent Arrangement shall be paid up to that day with a proportionate refund by BellSouth of such rent and charges as may have been paid in advance for a period subsequent to the date of the taking. If any part of the Collocation Space or Adjacent Arrangement shall be taken under eminent domain, BellSouth and ComSouth shall each have the right to terminate this Attachment with respect to such Collocation Space or Adjacent Arrangement and declare the same null and void, by written notice of such intention to the other Party within ten (10) days after such taking.

15 Nonexclusivity

- 15.1 ComSouth understands that this Attachment is not exclusive and that BellSouth may enter into similar agreements with other Parties. Assignment of Collocation Space pursuant to all such agreements shall be determined by space availability

and made on a first come, first serve basis.

ENVIRONMENTAL AND SAFETY PRINCIPLES

The following principles provide basic guidance on environmental and safety issues when applying for and establishing physical collocation arrangements.

1. General Principles

- 1.1 Compliance with Applicable Law. BellSouth and ComSouth agree to comply with applicable federal, state, and local environmental and safety laws and regulations including U.S. Environmental Protection Agency (USEPA) regulations issued under the Clean Air Act (CAA), Clean Water Act (CWA), Resource Conservation and Recovery Act (RCRA), Comprehensive Environmental Response, Compensation and Liability Act (CERCLA), Superfund Amendments and Reauthorization Act (SARA), the Toxic Substances Control Act (TSCA), and Occupational Safety and Healthy Act (OSHA) regulations issued under the OSHA of 1970, as amended and National Fire Protection Association (NFPA), NEC and NESC (Applicable Laws) requirements. Each Party shall notify the other if compliance inspections are conducted by regulatory agencies and/or citations are issued that relate to any aspect of this Attachment.
- 1.2 Notice. BellSouth and ComSouth shall provide notice to the other, including any Material Safety Data Sheets (MSDSs), of known and recognized physical hazards or Hazardous Chemicals existing on site or brought on site. A Hazardous Chemical inventory list is posted on an OSHA Poster and updated annually at each Central Office. This Poster is normally located near the front entrance of the building or in the lounge area. Each Party is required to provide specific notice for known potential Imminent Danger conditions. ComSouth should contact 1-800-743-6737 for any BellSouth MSDS required.
- 1.3 Practices/Procedures. BellSouth may make available additional environmental control procedures for ComSouth to follow when working at a BellSouth Premises (See Section 2, below). These practices/procedures will represent the regular work practices required to be followed by the employees and suppliers of BellSouth for environmental protection. ComSouth will require its suppliers, agents, Guests, and others accessing the BellSouth Premises to comply with these practices. Section 2 below lists the Environmental categories where BellSouth practices should be followed by ComSouth when operating in the BellSouth Premises.
- 1.4 Environmental and Safety Inspections. BellSouth reserves the right to inspect the ComSouth space with proper notification. BellSouth reserves the right to stop any ComSouth work operation that imposes Imminent Danger to the environment, employees or other persons in or around a BellSouth Premises.
- 1.5 Hazardous Materials Brought On Site. Any hazardous materials brought into, used, stored or abandoned at a BellSouth Premises by ComSouth are owned by and considered the property of ComSouth. ComSouth will indemnify BellSouth

for claims, lawsuits or damages to persons or property caused by these materials. Without prior written BellSouth approval, no substantial new safety or environmental hazards can be created by ComSouth or different hazardous materials used by ComSouth at a BellSouth Premises. ComSouth must demonstrate adequate emergency response capabilities for the materials used by ComSouth or remaining at a BellSouth Premises.

1.6 Spills and Releases. When contamination is discovered at a BellSouth Premises, either Party discovering the condition must notify the other Party. All Spills or Releases of regulated materials will immediately be reported by ComSouth to BellSouth.

1.7 Coordinated Environmental Plans and Permits. BellSouth and ComSouth will coordinate plans, permits or information required to be submitted to government agencies, such as emergency response plans, spill prevention control and countermeasures (SPCC) plans and community reporting. If fees are associated with filing, BellSouth and ComSouth will develop a cost sharing procedure. If BellSouth's permit or EPA identification number must be used, ComSouth must comply with all of BellSouth's permit conditions and environmental processes, including environmental "best management practices (BMP)" (see Section 2, below) and the selection of BST disposition vendors and disposal sites.

1.8 Environmental and Safety Indemnification. BellSouth and ComSouth shall indemnify, defend and hold harmless the other Party from and against any claims (including, without limitation, third-party claims for personal injury or death or real or personal property damage), judgments, damages (including direct and indirect damages and punitive damages), penalties, fines, forfeitures, costs, liabilities, interest and losses arising in connection with the violation or alleged violation of any Applicable Law or contractual obligation or the presence or alleged presence of contamination arising out of the acts or omissions of the indemnifying Party, its employees, agents, suppliers, or Guests concerning its operations at a BellSouth Premises.

2. Categories for Consideration of Environmental Issues

2.1 When performing functions that fall under the following Environmental categories on BellSouth's Premises, ComSouth agrees to comply with the applicable sections of the current issue of BellSouth's Environmental and Safety Methods and Procedures (M&Ps), incorporated herein by this reference. ComSouth further agrees to cooperate with BellSouth to ensure that ComSouth's employees, agents, suppliers and/or Guests are knowledgeable of and satisfy those provisions of BellSouth's Environmental M&Ps, which apply to the specific Environmental function being performed by ComSouth, its employees, agents, suppliers, and/or Guests.

2.2 The most current version of the reference documentation must be requested from ComSouth's BellSouth Regional Contract Manager (RCM).

Environmental Categories	Environmental Issues	Addressed By The Following Documentation
Disposal of hazardous material or other regulated material (e.g., batteries, fluorescent tubes, solvents & cleaning materials)	<p>Compliance with all applicable local, state & federal laws and regulations</p> <p>Pollution liability insurance</p> <p>EVET approval of supplier</p>	<p>Std T&C 450 Fact Sheet Series 17000</p> <p>Std T&C 660-3</p> <p>Approved Environmental Vendor List (Contact RCM Representative)</p>
Emergency response	Hazmat/waste release/spill fire safety emergency	Fact Sheet Series 17000 Building Emergency Operations Plan (EOP) (specific to and located on BellSouth's Premises)
Contract labor/outsourcing for services with environmental implications to be performed on BellSouth Premises (e.g., disposition of hazardous material/waste; maintenance of storage tanks)	<p>Compliance with all applicable local, state and federal laws and regulations</p> <p>Performance of services in accordance with BST's environmental M&Ps</p> <p>Insurance</p>	<p>Std T&C 450</p> <p>Std T&C 450-B (Contact RCM Representative for copy of appropriate E/S M&Ps.)</p> <p>Std T&C 660</p>
Transportation of hazardous material	<p>Compliance with all applicable local, state & federal laws and regulations</p> <p>Pollution liability insurance</p> <p>EVET approval of supplier</p>	<p>Std T&C 450 Fact Sheet Series 17000</p> <p>Std T&C 660-3</p> <p>Approved Environmental Vendor List (Contact RCM Representative)</p>
<p>Maintenance/operations work which may produce a waste</p> <p>Other maintenance work</p>	<p>Compliance with all applicable local, state & federal laws and regulations</p> <p>Protection of BST employees and equipment</p>	<p>Std T&C 450</p> <p>29 C.F.R. § 1910.147 (OSHA Standard)</p> <p>29 C.F.R. § 1910 Subpart O (OSHA Standard)</p>

Janitorial service	<p>All waste removal and disposal must conform to all applicable federal, state and local regulations</p> <p>All Hazardous Material and Waste</p> <p>Asbestos notification and protection of employees and equipment</p>	<p>Procurement Manager (CRES Related Matters)-BST Supply Chain Services</p> <p>Fact Sheet Series 17000</p> <p>GU-BTEN-001BT, Chapter 3 BSP 010-170-001BS (Hazcom)</p>
Manhole cleaning	<p>Compliance with all applicable local, state & federal laws and regulations</p> <p>Pollution liability insurance</p> <p>EVET approval of supplier</p>	<p>Std T&C 450 Fact Sheet 14050 BSP 620-145-011PR Issue A, August 1996</p> <p>Std T&C 660-3</p> <p>Approved Environmental Vendor List (Contact RCM Representative)</p>
Removing or disturbing building materials that may contain asbestos	Asbestos work practices	<p>GU-BTEN-001BT, Chapter 3 for questions regarding removing or disturbing materials that contain asbestos, call the BellSouth Building Service Center: AL, MS, TN, KY & LA (local area code) 557-6194 FL, GA, NC & SC (local area code) 780-2740</p>

3. Definitions

Generator. Under RCRA, the person whose act produces a Hazardous Waste, as defined in 40 C.F.R. § 261, or whose act first causes a Hazardous Waste to become subject to regulation. The Generator is legally responsible for the proper management and disposal of Hazardous Wastes in accordance with regulations.

Hazardous Chemical. As defined in the U.S. OSHA hazard communications standard (29 C.F.R. § 1910.1200), any chemical which is a health hazard or physical hazard.

Hazardous Waste. As defined in Section 1004 of RCRA.

Imminent Danger. Any conditions or practices at a BellSouth Premises which are such that a danger exists which could reasonably be expected to cause immediate death or serious harm to people or immediate significant damage to the environment or natural resources.

Spill or Release. As defined in Section 101 of CERCLA.

4.

Acronyms

RCM – Regional Collocation Manager (f/k/a Account Team Collocation Coordinator)

BST – BellSouth Telecommunications

CRES – Corporate Real Estate and Services (formerly PS&M)

DEC/LDEC – Department Environmental Coordinator/Local Department Environmental Coordinator

E/S – Environmental/Safety

EVET – Environmental Vendor Evaluation Team

GU-BTEN-001BT – BellSouth Environmental Methods and Procedures

NESC – National Electrical Safety Codes

P&SM – Property & Services Management

Std T&C – Standard Terms & Conditions

COLLOCATION - Georgia											Att: 4 Exh: B					
CATEGORY	RATE ELEMENTS	Interim	Zone	BCS	USOC	RATES(\$)				Svc Order Submitted Elec per LSR	Svc Order Submitted Manually per LSR	Incremental Charge - Manual Svc Order vs. Electronic-1st	Incremental Charge - Manual Svc Order vs. Electronic-Add'l	Incremental Charge - Manual Svc Order vs. Electronic-Disc 1st	Incremental Charge - Manual Svc Order vs. Electronic-Disc Add'l	
						Rec	Nonrecurring		Nonrecurring Disconnect							OSS Rates(\$)
							First	Add'l	First	Add'l	SOMEC	SOMAN	SOMAN	SOMAN	SOMAN	SOMAN
PHYSICAL COLLOCATION																
Application																
	Physical Collocation - Initial Application Fee			CLO	PE1BA		1,284.72		0.59							
	Physical Collocation - Subsequent Application Fee			CLO	PE1CA		1,084.41		0.59							
	Physical Collocation - Co-Carrier Cross Connects/Direct Connect, Application Fee, per application			CLO	PE1DT		583.18									
	Physical Collocation Administrative Only - Application Fee			CLO	PE1BL		740.83									
	Physical Collocation - Application Cost, Simple Augment			CLO	PE1KS		594.05		1.21							
	Physical Collocation - Application Cost, Minor Augment			CLO	PE1KM		832.95		1.21							
	Physical Collocation - Application Cost, Intermediate Augment			CLO	PE1K1		1,057.00		1.21							
	Physical Collocation - Application Cost - Major Augment			CLO	PE1KJ		2,408.00		1.21							
Space Preparation																
	Physical Collocation - Floor Space, per sq feet			CLO	PE1PJ		4.71									
	Physical Collocation - Space Enclosure, welded wire, first 50 square feet			CLO	PE1BX		144.71									
	Physical Collocation - Space enclosure, welded wire, first 100 square feet			CLO	PE1BW		167.00									
	Physical Collocation - Space enclosure, welded wire, each additional 50 square feet			CLO	PE1CW		16.38									
	Physical Collocation - Space Preparation - C.O. Modification per square ft.			CLO	PE1SK		2.10									
	Physical Collocation - Space Preparation, Common Systems Modifications-Cageless, per square foot			CLO	PE1SL		2.27									
	Physical Collocation - Space Preparation - Common Systems Modifications-Caged, per cage			CLO	PE1SM		77.24									
	Physical Collocation - Space Preparation - Firm Order Processing			CLO	PE1SJ		140.96									
	Physical Collocation - Space Availability Report, per Central Office Requested			CLO	PE1SR		248.50									
Power																
	Physical Collocation - Power, -48V DC Power - per Fused Amp Requested			CLO	PE1PL		4.84									
	Physical Collocation - Power, 120V AC Power, Single Phase, per Breaker Amp			CLO	PE1FB		5.16									
	Physical Collocation - Power, 240V AC Power, Single Phase, per Breaker Amp			CLO	PE1FD		10.34									
	Physical Collocation - Power, 120V AC Power, Three Phase, per Breaker Amp			CLO	PE1FE		15.50									
	Physical Collocation - Power, 277V AC Power, Three Phase, per Breaker Amp			CLO	PE1FG		35.79									
	Physical Collocation - Power - DC power using a CLEC BDFB, per Used Amp			CLO	PE1PW		6.45									
	Physical Collocation - Power, -48V DC Power using a CLEC BDFB - per Fused Amp Requested			CLO	PE1PX		4.31									
	Physical Collocation-Physical Meter Reading Expense			CLO	PE1FL		5.00									
	Physical Collocation - Power - DC power, per Used Amp			CLO	PE1FN		7.24									
	Physical Collocation-Additional Meter Reading Trip Charge, per Central Office per Occurrence			CLO	PE1FM		15.00									
Cross Connects (Cross Connects, Co-Carrier Cross Connects, and Ports)																
	Physical Collocation - 2-wire cross-connect, loop, provisioning			UEANL,UEQ, UNCNX, UEA, UCL, UAL, UHL, UDN, UNCVX	PE1P2		0.0202									
	Physical Collocation - 4-wire cross-connect, loop, provisioning			UEA, UHL, UNCVX, UNCDX, UCL, UDL	PE1P4		0.0403									
	Physical Collocation -DS1 Cross-Connect for Physical Collocation, provisioning			WDS1L, WDS1S, UXTD1, ULDD1, USLEL, UNLD1, U1TD1, UNC1X, UEPSR, UEPSB, UEPSE, UEPS, USL, UEPEX, UEPPX	PE1P1		0.3807									

COLLOCATION - Georgia											Att: 4 Exh: B					
CATEGORY	RATE ELEMENTS	Interim	Zone	BCS	USOC	RATES(\$)				Svc Order Submitted Elec per LSR	Svc Order Submitted Manually per LSR	Incremental Charge - Manual Svc Order vs. Electronic-1st	Incremental Charge - Manual Svc Order vs. Electronic-Add'l	Incremental Charge - Manual Svc Order vs. Electronic-Disc 1st	Incremental Charge - Manual Svc Order vs. Electronic-Disc Add'l	
						Rec	Nonrecurring		Nonrecurring Disconnect							OSS Rates(\$)
							First	Add'l	First	Add'l	SOMEC	SOMAN	SOMAN	SOMAN	SOMAN	SOMAN
	Physical Collocation - DS3 Cross-Connect, provisioning			UE3, U1TD3, UXTD3, UXTS1, UNC3X, UNCSX, ULDD3, U1TS1, ULDS1, UNLD3, UEPEX, UEPDX, UEPSR, UEPSB, UEPSE, UEPSP	PE1P3	4.15										
	Physical Collocation - 2-Fiber Cross-Connect			CLO, ULDO3, ULD12, ULD48, U1TO3, U1T12, U1T48, UDLO3, UDL12, UDF	PE1F2	1.76										
	Physical Collocation - 4-Fiber Cross-Connect			ULDO3, ULD12, ULD48, U1TO3, U1T12, U1T48, UDLO3, UDL12, UDF, UDFCX	PE1F4	3.38										
	Physical Collocation - Co-Carrier Cross Connects/Direct Connect - Fiber Cable Support Structure, per linear foot, per cable.			CLO	PE1ES	0.001										
	Physical Collocation - Co-Carrier Cross Connect/Direct Connect - Copper/Coax Cable Support Structure, per linear foot, per cable.			CLO	PE1DS	0.0015										
	Physical Collocation 2-Wire Cross Connect, Port			UEPSR, UEPSB, UEPSE, UEPSB, UEPSX, UEP2C	PE1R2	0.0202										
	Physical Collocation 4-Wire Cross Connect, Port			UEPEX, UEPDD	PE1R4	0.0403										
Security																
	Physical Collocation - Security Escort for Basic Time - normally scheduled work, per half hour			CLO	PE1BT		16.51	10.82								
	Physical Collocation - Security Escort for Overtime - outside of normally scheduled working hours on a scheduled work day, per half hour			CLO	PE1OT		21.90	14.17								
	Physical Collocation - Security Escort for Premium Time - outside of scheduled work day, per half hour			CLO	PE1PT		27.29	17.53								
	Physical Collocation - Security Access System - Security System per Central Office, per Sq. Ft.			CLO	PE1AY	0.011										
	Physical Collocation - Security Access System - New Card Activation, per Card Activation (First), per State			CLO	PE1A1		21.98									
	Physical Collocation - Security Access System - New Access Card Deactivation, per Card			CLO	PE1A4		8.72	8.72								
	Physical Collocation - Security Access System - Administrative Change, existing Access Card, per Request, per State, per Card			CLO	PE1AA		5.37									
	Physical Collocation - Security Access System - Replace Lost or Stolen Card, per Card			CLO	PE1AR		16.99									
	Physical Collocation - Security Access - Initial Key, per Key			CLO	PE1AK		13.19									
	Physical Collocation - Security Access - Key, Replace Lost or Stolen Key, per Key			CLO	PE1AL		13.19									
CFA																
	Physical Collocation - CFA Information Resend Request, per premises, per arrangement, per request			CLO	PE1C9		77.42									
Cable Records - Note: The rates in the First & Additional columns will actually be billed as "Initial I" and "Subsequent S" respectively																
	Physical Collocation - Cable Records, per request			CLO	PE1CR		I 742.92	S 477.59	125.63							
	Physical Collocation, Cable Records, VG/DS0 Cable, per cable record (maximum 3600 records)			CLO	PE1CD		317.29		177.60							
	Physical Collocation, Cable Records, VG/DS0 Cable, per each 100 pair			CLO	PE1CO		4.47		5.29							
	Physical Collocation, Cable Records, DS1, per T1 TIE			CLO	PE1C1		2.22		2.62							
	Physical Collocation, Cable Records, DS3, per T3 TIE			CLO	PE1C3		7.76		9.18							
	Physical Collocation - Cable Records, Fiber Cable, per cable record (maximum 99 records)			CLO	PE1CB		83.37		73.49							
	Physical Collocation, Cable Records, CAT5/RJ45			CLO	PE1C5		2.22		2.62							

COLLOCATION - Georgia											Att: 4 Exh: B				
CATEGORY	RATE ELEMENTS	Interim	Zone	BCS	USOC	RATES(\$)				Svc Order Submitted Elec per LSR	Svc Order Submitted Manually per LSR	Incremental Charge - Manual Svc Order vs. Electronic-1st	Incremental Charge - Manual Svc Order vs. Electronic-Add'l	Incremental Charge - Manual Svc Order vs. Electronic-Disc 1st	Incremental Charge - Manual Svc Order vs. Electronic-Disc Add'l
						Rec	Nonrecurring		Nonrecurring Disconnect						
							First	Add'l	First	Add'l	SOMEc	SOMAN	SOMAN	SOMAN	SOMAN
Virtual to Physical															
	Physical Collocation - Virtual to Physical Collocation Relocation, per Voice Grade Circuit			CLO	PE1BV		33.00								
	Physical Collocation - Virtual to Physical Collocation Relocation, per DSO Circuit			CLO	PE1BO		33.00								
	Physical Collocation - Virtual to Physical Collocation Relocation, per DS1 Circuit			CLO	PE1B1		52.00								
	Physical Collocation - Virtual to Physical Collocation Relocation, per DS3 Circuit			CLO	PE1B3		52.00								
	Physical Collocation - Virtual to Physical Collocation In-Place, Per Voice Grade Circuit			CLO	PE1BR		22.59								
	Physical Collocation Virtual to Physical Collocation In-Place, Per DSO Circuit			CLO	PE1BP		22.59								
	Physical Collocation - Virtual to Physical Collocation In-Place, Per DS1 Circuit			CLO	PE1BS		32.85								
	Physical Collocation - Virtual to Physical Collocation In-Place, per DS3 Circuit			CLO	PE1BE		32.85								
Entrance Cable															
	Physical Collocation - Fiber Cable Installation, Pricing, non-recurring charge, per Entrance Cable			CLO	PE1BD		736.20		21.49						
	Physical Collocation - Fiber Cable Support Structure, per Entrance Cable			CLO	PE1PM	7.37									
	Physical Collocation, Entrance Cable Support Structure, Copper, per each 100 pairs or fraction thereof (CO Manhole to Collocation Space)			CLO	PE1EE	0.2686									
	Physical Collocation, Entrance Cable Installation, Copper, per Cable (CO Manhole to Collocation Space)			CLO	PE1EF		754.41		21.49						
	Physical Collocation, Entrance Cable Installation, Copper, per each 100 pairs or fraction thereof (CO Manhole to Collocation Space)			CLO	PE1EG		9.11								
	Physical Collocation - Fiber Entrance Cable Installation, per Fiber			CLO	PE1ED		3.90								
VIRTUAL COLLOCATION															
Application															
	Virtual Collocation - Application Fee			AMTFS	EAF		608.92		0.59						
	Virtual Collocation - Co-Carrier Cross Connects/Direct Connect, Application Fee, per application			AMTFS	VE1CA		583.18								
	Virtual Collocation Administrative Only - Application Fee			AMTFS	VE1AF		609.52								
Space Preparation															
	Virtual Collocation - Floor Space, per sq. ft.			AMTFS	ESPVX	4.71									
Power															
	Virtual Collocation - Power, per fused amp			AMTFS	ESPAX	4.84									
Cross Connects (Cross Connects, Co-Carrier Cross Connects, and Ports)															
	Virtual Collocation - 2-wire cross-connect, loop, provisioning			UEANL, UEA, UDN, UAL, UHL, UCL, UEQ, UNCVX, UNCDX, UNCNX	UEAC2	0.0192									
	Virtual Collocation - 4-wire cross-connect, loop, provisioning			UEA, UHL, UCL, UDL, UNCVX, UNCDX	UEAC4	0.0385									
	Virtual collocation - Special Access & UNE, cross-connect per DS1			ULR, UXTD1, UNC1X, ULDD1, U1TD1, USLEL, UNLD1, USL, UEPEX, UEPDX	CNC1X	0.3807									
	Virtual collocation - Special Access & UNE, cross-connect per DS3			USL, UE3, U1TD3, UXTS1, UXTD3, UNC3X, UNC3X, ULDD3, U1TS1, ULDS1, UDLSX, UNLD3, XDEST	CND3X	4.15									

COLLOCATION - Georgia											Att: 4 Exh: B					
CATEGORY	RATE ELEMENTS	Interim	Zone	BCS	USOC	RATES(\$)				Svc Order Submitted Elec per LSR	Svc Order Submitted Manually per LSR	Incremental Charge - Manual Svc Order vs. Electronic-1st	Incremental Charge - Manual Svc Order vs. Electronic-Add'l	Incremental Charge - Manual Svc Order vs. Electronic-Disc 1st	Incremental Charge - Manual Svc Order vs. Electronic-Disc Add'l	
						Rec	Nonrecurring		Nonrecurring Disconnect							OSS Rates(\$)
							First	Add'l	First	Add'l	SOMEC	SOMAN	SOMAN	SOMAN	SOMAN	SOMAN
	Physical Collocation in the Remote Site - Space Availability Report per Premises Requested			CLORS	PE1SR		109.83									
	Physical Collocation in the Remote Site - Remote Site CLLI Code Request, per CLLI Code Requested			CLORS	PE1RE		36.00									
	Remote Site DLEC Data (BRSDDD), per Compact Disk, per CO			CLORS	PE1RR		116.71									
	Physical Collocation - Security Escort for Basic Time - normally scheduled work, per half hour			CLORS	PE1BT		16.51	10.82								
	Physical Collocation - Security Escort for Overtime - outside of normally scheduled working hours on a scheduled work day, per half hour			CLORS	PE1OT		21.90	14.17								
	Physical Collocation - Security Escort for Premium Time - outside of scheduled work day, per half hour			CLORS	PE1PT		27.29	17.53								
Adjacent Remote Site Collocation																
	Remote Site-Adjacent Collocation-Application Fee			CLORS	PE1RU		755.62	755.62								
	Remote Site-Adjacent Collocation - Real Estate, per square foot			CLORS	PE1RT	0.134										
	Remote Site-Adjacent Collocation - AC Power, per breaker amp			CLORS	PE1RS	6.27										
NOTE: If Security Escort and/or Add'l Engineering Fees become necessary for adjacent remote site collocation, the Parties will negotiate appropriate rates.																
Virtual Remote Site Collocation																
	Virtual Collocation in the Remote Site - Application Fee			VE1RS	VE1RB		300.31		132.49							
	Virtual Collocation in the Remote Site - Per Bay/Rack of Space			VE1RS	VE1RC	148.11										
	Virtual Collocation in the Remote Site - Space Availability Report per Premises requested			VE1RS	VE1RR		109.83									
	Virtual Collocation in the Remote Site - Remote Site CLLI Code Request, per CLLI Code Requested			VE1RS	VE1RL		36.00									
ADJACENT COLLOCATION																
	Adjacent Collocation - Space Charge per Sq. Ft.			CLOAC	PE1JA	0.1725										
	Adjacent Collocation - Electrical Facility Charge per Linear Ft.			CLOAC	PE1JC	4.12										
	Adjacent Collocation - 2-Wire Cross-Connects			UEANL,UEQ,UEA,UCL,UAL,UHL,UDN	PE1JE	0.0176										
	Adjacent Collocation - 4-Wire Cross-Connects			UEA,UHL,UDL,UCL	PE1JF	0.0353										
	Adjacent Collocation - DS1 Cross-Connects			USL	PE1JG	0.3686										
	Adjacent Collocation - DS3 Cross-Connects			UE3	PE1JH	4.83										
	Adjacent Collocation - 2-Fiber Cross-Connect			CLOAC	PE1JJ	1.69										
	Adjacent Collocation - 4-Fiber Cross-Connect			CLOAC	PE1JK	3.31										
	Adjacent Collocation - Application Fee			CLOAC	PE1JB		1,380.83		0.50							
	Adjacent Collocation - 120V, Single Phase Standby Power Rate per AC Breaker Amp			CLOAC	PE1JL	5.16										
	Adjacent Collocation - 240V, Single Phase Standby Power Rate per AC Breaker Amp			CLOAC	PE1JM	10.34										
	Adjacent Collocation - 120V, Three Phase Standby Power Rate per AC Breaker Amp			CLOAC	PE1JN	15.50										
	Adjacent Collocation - 277V, Three Phase Standby Power Rate per AC Breaker Amp			CLOAC	PE1JO	35.79										
	Adjacent Collocation - 240V, Three Phase Standby Power Rate per AC Breaker Amp			CLOAC	PE1JD	35.79										

Attachment 5
Access to Numbers and Number Portability

TABLE OF CONTENTS

1. Non-Discriminatory Access to Telephone Numbers..... 3

2. Local Number Portability 4

3. Service Order Charges..... 5

ACCESS TO NUMBERS AND NUMBER PORTABILITY

1. Non-Discriminatory Access to Telephone Numbers

- 1.1 During the term of this Agreement, where ComSouth is utilizing its own switch, ComSouth shall contact the North American Numbering Plan Administrator (NANPA), or, where applicable, the relevant Number Pool Administrator for the assignment of numbering resources.
- 1.2 Where BellSouth provides resold services to ComSouth, BellSouth will provide ComSouth with online access to available telephone numbers as defined by applicable FCC rules and regulations on a first come first served basis. ComSouth acknowledges that such access to numbers shall be in accordance with the appropriate FCC rules and regulations. ComSouth may designate up to a forecasted six (6) months supply of available numbers as intermediate (an available number provided to ComSouth) telephone numbers per rate center if the following conditions are met:
 - 1.2.1 ComSouth must: (1) indicate that all of the intermediate numbers currently held by ComSouth in each rate center where ComSouth will be requesting intermediate telephone numbers have six (6) or less months to exhaust; (2) supply projected monthly telephone number demand on a rate center basis for the coming twelve (12) months for each rate center where ComSouth will be requesting intermediate telephone numbers; and, (3) demonstrate that the utilization level on current intermediate numbers held by ComSouth in the rate center where ComSouth is requesting telephone numbers has reached at least seventy-five percent (75%).
 - 1.2.2 The above information will be provided by ComSouth by submitting to BellSouth a fully completed "CO Code Assignments Months To Exhaust Certification Worksheet – TN Level" (MTE Worksheet), Appendix B to the Central Office Code (NXX) Assignments Guidelines, INC 95-0407-008 for each rate center where ComSouth will be requesting intermediate telephone numbers. The utilization level is calculated by dividing all intermediate numbers currently assigned by ComSouth to customers by the total number of intermediate numbers held by ComSouth in the rate center and multiplying the result by one hundred (100).
 - 1.2.3 If fulfilling ComSouth's request for intermediate numbers results in BellSouth having to submit a request for additional telephone numbers to a national numbering administrator (either NANPA CO Code Administration or NeuStar Pooling Administration or their successors), BellSouth will submit the required numbering request to the national numbering administrator to satisfy ComSouth's

request for intermediate numbers. BellSouth will also pursue all appropriate steps (including submitting a safety valve request (petition) to the appropriate Commission if the numbering request is denied by the national administrator) to satisfy ComSouth's request for intermediate numbers. In these cases, BellSouth is not obligated to fulfill the request by ComSouth for intermediate numbers unless, and until, BellSouth's request for additional numbering resources is granted.

1.2.4 ComSouth agrees to supply supporting information for any numbering request and/or safety valve request that BellSouth files pursuant to Section 1.2.3 above.

1.3 ComSouth acknowledges that there may be instances where there is an industry shortage of available telephone numbers in a number plan area (NPA). These instances occur where a jeopardy status has been declared by NANPA and the industry has determined that limiting the assignment of new numbers is the appropriate method to employ until the jeopardy can be alleviated. In such NPA jeopardy situations where assignment of new numbers is restricted per the jeopardy guidelines developed by the industry, BellSouth may request that ComSouth cancel all or a portion of its unassigned intermediate numbers. ComSouth's consent to BellSouth's request shall not be unreasonably withheld.

2. Local Number Portability

2.1 The Parties will offer LNP in accordance with rules, regulations and guidelines adopted by the Commission, the FCC and industry fora.

2.2 Service Management System (SMS) Administration. The Parties will work cooperatively with other local service providers to establish and maintain contracts for the LNP SMS.

2.3 Network Architecture. The Parties agree to adhere to applicable FCC rules and orders governing LNP network architecture.

2.4 Signaling. In connection with LNP, each Party agrees to use SS7 signaling in accordance with applicable FCC rules and orders.

2.5 N-1 Query. The Parties agree to adhere to applicable FCC rules and orders governing LNP N-1 queries.

2.6 Porting of Reserved Numbers and Suspended Lines. Customers of each Party may port numbers, via LNP, that are in a denied state or that are on suspend status. In addition, customers of each Party may port reserved numbers that the customer has paid to reserve. Portable reserved numbers are identified on the Customer Service Record (CSR). In anticipation of porting from one Party to the other Party, a Party's customer may reserve additional telephone numbers and include them with the numbers that are subsequently ported to the other Party. It is not necessary to restore a denied number before it is ported.

- 2.7 Splitting of Number Groups. The Parties shall permit blocks of subscriber numbers (including, but not limited to, Direct Inward Dial (DID) numbers and MultiServ groups) to be split in connection with an LNP request. BellSouth and ComSouth shall permit customers who port a portion of DID numbers to retain DID service on the remaining portion of numbers. If a Party requests porting a range of DID numbers smaller than a whole block, that Party shall pay the applicable charges for doing so as set forth in Attachment 2. In the event no rate is set forth in Attachment 2, then the Parties shall negotiate a rate for such services.
- 2.8 The Parties will set Location Routing Number (LRN) unconditional or ten (10) digit triggers where applicable. Where triggers are set, the porting Party will remove the ported number at the same time the trigger is removed.
- 2.9 A trigger order is a service order issued in advance of the porting of a number. A trigger order 1) initiates call queries to the AIN SS7 network in advance of the number being ported; and 2) provides for the new service provider to be in control of when a number ports.
- 2.10 Where triggers are not set, the Parties shall coordinate the porting of the number between service providers so as to minimize service interruptions to the customer.
- 2.11 BellSouth and ComSouth will work cooperatively to implement changes to LNP process flows ordered by the FCC or as recommended by standard industry forums addressing LNP.
- 2.12 Where ComSouth utilizes BellSouth's LNP Query Service, BellSouth shall bill and ComSouth shall pay the query charge associated with LNP Query Service as set forth in Attachment 2. To receive the LNP Query Service charge set forth in Attachment 2, ComSouth shall fill out and submit the Interconnection data sheet for BellSouth LNP Query Service. The form can be obtained on BellSouth's Interconnection Web site under BellSouth LNP Query Service and click on forms. Once the form has been filled out and submitted the LNP Query charge will take effect on the approved date. This charge is not subject to the resale discount set forth in Attachment 1.
- 3. Service Order Charges**
- 3.1 The terms, conditions and rates for OSS utilized in connection with LNP are as set forth in Attachment 6 and Exhibit A of Attachment 2.

Attachment 6
Pre-Ordering, Ordering, Provisioning,
Maintenance and Repair

TABLE OF CONTENTS

1. Quality of Pre-Ordering, Ordering, Provisioning, Maintenance and Repair 3

2. Access to Operations Support Systems..... 3

3. Miscellaneous..... 8

PRE-ORDERING, ORDERING, PROVISIONING, MAINTENANCE AND REPAIR

1. Quality of Pre-Ordering, Ordering, Provisioning, Maintenance and Repair

- 1.1 BellSouth shall provide to ComSouth nondiscriminatory access to its OSS and the necessary information contained therein in order that ComSouth can perform the functions of pre-ordering, ordering, provisioning, maintenance and repair, and billing. BellSouth shall provide ComSouth with all relevant documentation (manuals, user guides, specifications, etc.) regarding business rules and other formatting information as well as practices and procedures necessary to ensure requests are efficiently processed. All documentation will be readily accessible at BellSouth's Interconnection Web site. BellSouth shall ensure that its OSS are designed to accommodate requests for both current and projected demands of ComSouth and other CLECs in the aggregate.

2. Access to Operations Support Systems

- 2.1 BellSouth shall provide to ComSouth nondiscriminatory access to its OSS and the necessary information contained therein in order that ComSouth can perform the functions of pre-ordering, ordering, provisioning, maintenance and repair, and billing. BellSouth shall provide nondiscriminatory access to the OSS through manual and/or electronic interfaces as described in this Attachment. It is the sole responsibility of ComSouth to obtain the technical capability to access and utilize BellSouth's OSS interfaces. Specifications for ComSouth's access and use of BellSouth's electronic interfaces are set forth at BellSouth's Interconnection Web site.

- 2.1.1 ComSouth agrees to comply with the provisions of the OSS Interconnection Volume Guidelines as set forth at BellSouth's Interconnection Web site.

2.2 Pre-Ordering

- 2.2.1 BellSouth will provide electronic access to its OSS and the information contained therein in order that ComSouth can perform the following pre-ordering functions: service address validation, telephone number selection, service and feature availability, due date information, customer record information and loop makeup information. Mechanized access is provided by electronic interfaces whose specifications for access and use are set forth at BellSouth's Interconnection Web site. The process by which the Parties will manage these electronic interfaces to include the development and introduction of new interfaces will be governed by the change management process as described in Section 2.7 below.

- 2.2.2 BellSouth shall provide to ComSouth electronic access to customer service record information in accordance with the applicable performance intervals referenced in Attachment 9. If electronic access is not available, BellSouth shall provide to ComSouth such information within twenty-four (24) hours. ComSouth shall provide to BellSouth access to customer record information, including circuit numbers associated with each telephone number where applicable. ComSouth shall provide such information within four (4) hours after request via electronic access where available. If electronic access is not available, ComSouth shall provide to BellSouth paper copies of customer record information, including circuit numbers associated with each telephone number where applicable. ComSouth shall provide to BellSouth such customer service records within twenty-four (24) hours of a valid request, exclusive of Saturdays, Sundays and holidays.
- 2.2.3 The Parties agree not to view, copy, or otherwise obtain access to the other Party's customer record information about any of the other Party's customers without that customer's permission. ComSouth will obtain access to customer record information only in strict compliance with applicable laws, rules, or regulations of the state in which the service is provided. BellSouth reserves the right to audit ComSouth's access to customer record information. If BellSouth has reason to believe, through its audit or by any other means, that ComSouth is accessing customer record information without having obtained the proper customer authorization, BellSouth upon reasonable notice to ComSouth may take corrective action, including but not limited to suspending or terminating ComSouth's access to BellSouth's pre-ordering and ordering OSS, and the provisioning of pending and existing services.
- 2.3 Ordering
- 2.3.1 BellSouth will make available to ComSouth electronic interfaces for the purpose of exchanging order information, including order status and completion notification, for non-complex and certain complex resale requests and certain network elements. Specifications for access and use of BellSouth's electronic interfaces are set forth at BellSouth's Interconnection Web site. The process by which the Parties will manage these electronic interfaces to include the development and introduction of new interfaces will be governed by the change management process as described in Section 2.7 below.
- 2.3.2 ComSouth shall place orders for services by submitting a LSR to BellSouth. BellSouth shall bill ComSouth an electronic service order charge at the rate set forth in the applicable Attachment to this Agreement for each LSR submitted by means of an electronic interface. BellSouth shall bill ComSouth a manual service order charge at the rate set forth in the applicable Attachment to this Agreement for each LSR submitted by means other than the electronic Interfaces (e.g., mail,

fax, courier, etc.). An individual LSR will be identified for billing purposes by its PON.

- 2.3.2.1 ComSouth may submit an LSR to request that a customer's service be temporarily suspended, denied, or restored. Alternatively, ComSouth may submit a list of such customers if ComSouth provides a separate PON for each location on the list. BellSouth will bill an electronic or manual service order charge for each location.
- 2.3.2.2 BellSouth will bill the electronic or manual service order charge, as applicable, for an LSR, regardless of whether that LSR is later supplemented, clarified or cancelled.
- 2.3.2.3 Notwithstanding the foregoing, BellSouth will not bill an additional electronic or manual service order charge for supplements to any LSR submitted to clarify, correct, change or cancel a previously submitted LSR.
- 2.3.2.4 BellSouth shall return a Firm Order Confirmation (FOC) or LSR clarification in accordance with the applicable performance intervals referenced in Attachment 9. ComSouth shall provide to BellSouth a FOC within twenty-four (24) hours of the receipt from BellSouth of a complete and accurate LSR, exclusive of Saturdays, Sundays and holidays. ComSouth shall provide to BellSouth an LSR clarification within twenty-four (24) hours of the receipt from BellSouth of an incomplete and inaccurate LSR, exclusive of Saturdays, Sundays and holidays.

2.4 Provisioning

- 2.4.1 BellSouth shall provision services during its regular working hours. To the extent ComSouth requests provisioning of service to be performed outside BellSouth's regular working hours, or the work so requested requires BellSouth's technicians or project managers to work outside of regular working hours, overtime charges set forth in BellSouth's intrastate Access Services Tariff, Section E13.2, shall apply. Notwithstanding the foregoing, if such work is performed outside of regular working hours by a BellSouth technician or project manager during his or her scheduled shift and BellSouth does not incur any overtime charges in performing the work on behalf of ComSouth, BellSouth will not assess ComSouth additional charges beyond the rates and charges specified in this Agreement.
- 2.4.2 In the event BellSouth must dispatch to the customer's location more than once due to incorrect or incomplete information provided by ComSouth (e.g., incomplete address, incorrect contact name/number, etc.), BellSouth will bill ComSouth for each additional dispatch required to provision the circuit due to the incorrect/incomplete information provided. BellSouth will assess the applicable Maintenance of Service rates from BellSouth's FCC No. 1 Tariff, Section 13.3.1.
- 2.4.3 Cancellation Charges. If ComSouth cancels an LSR for network elements or resold services subsequent to BellSouth's generation of a service order, any costs

incurred by BellSouth in conjunction with provisioning of Services as requested on the cancelled LSR will be recovered in accordance with the cancellation methodology set forth in the Cancellation Charge Percentage Chart found on BellSouth's Interconnection Web site. In addition, BellSouth reserves the right to assess cancellation charges if ComSouth fails to respond within nine (9) business days to a Missed Appointment order notification.

- 2.4.3.1 Notwithstanding the foregoing, if ComSouth places an LSR based upon BellSouth's loop makeup information, and such information is inaccurate resulting in the inability of BellSouth to provision the network elements requested and another spare compatible facility cannot be found with the transmission characteristics of the network elements originally requested, cancellation charges described in this Section shall not apply. Where ComSouth places a single LSR for multiple network elements or services based upon loop makeup information, and information as to some, but not all, of the network elements or services is inaccurate, if BellSouth cannot provision the network elements or services that were the subject of the inaccurate loop makeup information, ComSouth may cancel its request for those network elements or services without incurring cancellation charges as described in this Section. In such instance, should ComSouth elect to cancel the entire LSR, cancellation charges as described in this Section shall apply to those elements and services that were not the subject of inaccurate loop makeup.
- 2.4.4 Service Date Advancement Charges (Expedites). For Service Date Advancement requests by ComSouth, Service Date Advancement charges will apply for intervals less than the standard interval as outlined in the BellSouth Product and Services Interval Guide. The charges are as set forth in Exhibit A of Attachment 2.
- 2.4.5 Order Modification Charges. If ComSouth modifies an order after being sent a FOC from BellSouth, the Order Modification Charge (OMC) or Order Modification Charge Additional Dispatch (OMCAD) will be paid by ComSouth in accordance with Exhibit A of Attachment 2.
- 2.5 Maintenance and Repair
- 2.5.1 BellSouth will make available to ComSouth electronic interfaces for the purpose of reporting and monitoring service troubles. Specifications for access and use of BellSouth's maintenance and repair electronic interfaces are set forth at BellSouth's Interconnection Web site. The process by which the Parties will manage these electronic interfaces to include the development and introduction of new interfaces will be governed by the change management process as described in Section 2.7 below. Requests for trouble repair are billed in accordance with the provisions of this Agreement. BellSouth and ComSouth agree to adhere to BellSouth's Operational Understanding. The Operational Understanding may be accessed via BellSouth's Interconnection Web site.

- 2.5.2 If ComSouth reports a trouble on a BellSouth Network Element and no trouble is found in BellSouth's network, BellSouth will charge ComSouth a Maintenance of Service Charge for any dispatching and testing (both inside and outside the CO) required by BellSouth in order to confirm the working status. BellSouth will assess the Maintenance of Service rates as set forth in BellSouth's FCC No. 1 Tariff, Section 13.3.1.
- 2.5.2.1 In the event BellSouth must dispatch to the customer's location more than once due to incorrect or incomplete information provided by ComSouth (e.g., incomplete address, incorrect contact name/number, etc.), BellSouth will bill ComSouth for each additional dispatch required to repair the circuit due to the incorrect/incomplete information provided. BellSouth will assess the Maintenance of Service rates as set forth in BellSouth's FCC No. 1 Tariff, Section 13.3.1.
- 2.5.3 If ComSouth reports a trouble on a or a resold service and no trouble is found in BellSouth's network, BellSouth will charge ComSouth a Trouble Determination Charge or a Trouble Location Charge for any dispatching and testing (both inside and outside the CO) required by BellSouth in order to confirm the working status. BellSouth will assess the Trouble Determination Charge or Trouble Location Charge from the applicable BellSouth tariff.
- 2.5.3.1 In the event BellSouth must dispatch to the customer's location more than once due to incorrect or incomplete information provided by ComSouth (e.g., incomplete address, incorrect contact name/number, etc.), BellSouth will bill ComSouth for each additional dispatch required to repair the circuit due to the incorrect/incomplete information provided. BellSouth will assess the Trouble Determination Charge or Trouble Location Charge from the applicable BellSouth tariff.
- 2.6 Billing. BellSouth will provide ComSouth nondiscriminatory access to billing information as specified in Attachment 7.
- 2.7 Change Management. The Parties agree that the collaborative change management process known as the Change Control Process (CCP) will be used to manage changes to existing interfaces, introduction of new interfaces and retirement of interfaces. The Parties agree to comply with the provisions of the documented CCP as may be amended from time to time and incorporated herein by reference. The change management process will cover changes to BellSouth's electronic interfaces, BellSouth's testing environment, associated manual process improvements, and relevant documentation. The process will define a procedure for resolution of change management disputes. Documentation of the CCP as well as related information and processes will be clearly organized and readily accessible to ComSouth at BellSouth's Interconnection Web site.

- 2.8 Rates. Unless otherwise specified herein, charges for the use of BellSouth's OSS, and other charges applicable to pre-ordering, ordering, provisioning and maintenance and repair, shall be at the rates set forth in the applicable Attachment of this Agreement.
- 2.9 The Commissions in some states have ordered per element manual additive nonrecurring charges for Network Elements and Other Services ordered by means other than one of the interactive interfaces. These ordered Network Elements and Other Services manual additive nonrecurring charges will apply in these states, rather than the charge per LSR. The per element charges are listed in Exhibit A of Attachment 2.
- 3. Miscellaneous**
- 3.1 Pending Orders. To the extent that ComSouth submits an LSR with incomplete, incorrect or conflicting information, BellSouth will return the LSR to ComSouth for clarification. ComSouth shall respond to the request for clarification within thirty (30) days by submitting a supplemental LSR. If ComSouth does not submit a supplement LSR within thirty (30) days, BellSouth will cancel the original LSR and ComSouth shall be required to submit a new LSR, with a new PON.
- 3.2 Single Point of Contact. ComSouth will be the single point of contact with BellSouth for ordering activity for network elements and other services used by ComSouth to provide services to its customers, except that BellSouth may accept a request directly from another CLEC, or BellSouth, acting with authorization of the affected customer. ComSouth and BellSouth shall each execute a blanket LOA with respect to customer requests so that prior proof of customer authorization will not be necessary with every request (except in the case of a local service freeze). The Parties shall each be entitled to adopt their own internal processes for verification of customer authorization for requests, provided, however, that such processes shall comply with applicable state and federal law and industry and regulatory guidelines. Pursuant to a request from another carrier, BellSouth may disconnect any network element being used by ComSouth to provide service to that customer and may reuse such network elements or facilities to enable such other carrier to provide service to the customer. BellSouth will notify ComSouth that such a request has been processed but will not be required to notify ComSouth in advance of such processing.
- 3.2.1 Neither Party shall prevent or delay a customer from migrating to another carrier because of unpaid bills, denied service, or contract terms.
- 3.2.2 Use of Facilities. When a customer of ComSouth elects to discontinue service and to transfer service to another local exchange carrier, including BellSouth, BellSouth shall have the right to reuse the facilities provided to ComSouth, regardless whether those facilities are provided as Network Elements or as part of

a resold service, and regardless of whether the end user served with such facilities has paid all charges to ComSouth or has been denied service for nonpayment or otherwise. BellSouth will notify ComSouth that such a request has been processed after the disconnect order has been completed.

- 3.3 Contact Numbers. The Parties agree to provide one another with toll-free nation-wide (50 states) contact numbers for the purpose of ordering, provisioning and maintenance of services. Contact numbers for maintenance/repair of services shall be staffed twenty-four (24) hours per day, seven (7) days per week. BellSouth will close trouble tickets after making a reasonable effort to contact ComSouth for authorization to close a ticket. BellSouth will place trouble tickets in delayed maintenance status after making a reasonable effort to contact ComSouth to request additional information or to request authorization for additional work deemed necessary by BellSouth.
- 3.4 Subscription Functions. In cases where BellSouth performs subscription functions for an IXC (i.e., PIC and LPIC changes via Customer Account Record Exchange (CARE)), BellSouth will in all possible instances provide the affected IXCs with the OCN of the local provider for the purpose of obtaining customer billing account and other customer information required under subscription requirements.
- 3.4.1 When ComSouth's customer, served by resale or loop and port combinations, changes its PIC or LPIC, and per BellSouth's FCC or state tariff the interexchange carrier elects to charge the customer the PIC or LPIC change charge, BellSouth will bill the PIC or LPIC change charge to ComSouth, which has the billing relationship with that customer, and ComSouth may pass such charge to the customer.

Attachment 7

Billing

TABLE OF CONTENTS

1. Payment and Billing Arrangements..... 3

2. Billing Disputes 9

3. Non-Intercompany Settlements..... 10

BILLING

1. Payment and Billing Arrangements

The terms and conditions set forth in this Attachment shall apply to all services ordered and provisioned pursuant to this Agreement.

- 1.1 BellSouth will bill through the Carrier Access Billing System (CABS), Integrated Billing System (IBS) and/or the Customer Records Information Systems (CRIS) depending on the particular service(s) provided to ComSouth under this Agreement. BellSouth will format all bills in CABS Billing Output Specification (CBOS) Standard or CLUB/EDI format, depending on the type of service provided. For those services where standards have not yet been developed, BellSouth's billing format may change in accordance with applicable industry standards.
 - 1.1.1 For any service(s) BellSouth receives from ComSouth, ComSouth shall bill BellSouth in CBOS format.
 - 1.1.2 Any switched access charges associated with interexchange carrier access to the resold local exchange lines will be billed by, and due to BellSouth.
 - 1.1.3 BellSouth will render bills each month on established bill days for each of ComSouth's accounts. If either Party requests multiple billing media or additional copies of the bills, the billing Party will provide these at the rates set forth in BellSouth's FCC No. 1 Tariff, Section 13.3.6.3, except for resold services which shall be at the rates set forth in BellSouth's Non-Regulated Services Pricing List N6.
 - 1.1.4 BellSouth will bill ComSouth in advance for all services to be provided during the ensuing billing period except charges associated with service usage and nonrecurring charges, which will be billed in arrears.
 - 1.1.4.1 For resold services, charges for services will be calculated on an individual customer account level, including, if applicable, any charge for usage or usage allowances. BellSouth will also bill ComSouth, and ComSouth will be responsible for and remit to BellSouth, all charges applicable to said services including but not limited to 911 and E911 charges, EUCL charges, federal subscriber line charges, telecommunications relay charges, and franchise fees, unless otherwise ordered by a Commission.
 - 1.1.5 BellSouth will not perform billing and collection services for ComSouth as a result of the execution of this Agreement.
- 1.2 Establishing Accounts and Subsequent State Certifications. After submitting a credit profile and deposit, if required, and after receiving certification as a local exchange carrier from the appropriate Commission, ComSouth will provide the appropriate BellSouth Local Contract Manager responsible for new CLEC

activation, the necessary documentation to enable BellSouth to establish accounts for Local Interconnection, Network Elements and Other Services and/or resold services. Such documentation shall include the Application for Master Account, if applicable, proof of authority to provide Telecommunications Services, the appropriate OCN for each state as assigned by the NECA, CIC, if applicable, ACNA, if applicable, BellSouth's blanket form LOA, Misdirected Number form, and a tax exemption certificate, if applicable. Notwithstanding anything to the contrary in this Agreement, ComSouth may not order services under a new account and/or subsequent state certification, established in accordance with this Section until thirty (30) days after all information specified in this Section is received from ComSouth.

- 1.2.1 ACNAs. ComSouth shall provide BellSouth with documentation from Telcordia identifying the ACNA assigned to it by Telcordia (as applicable) in the same legal name as reflected in the preamble to this Agreement. Such ACNA will be used by ComSouth to order services pursuant to this Agreement and will not be shared by ComSouth with another entity.
- 1.2.2 Company Identifiers. If ComSouth needs to change, add to, eliminate or convert its OCN(s), ACNAs and other identifying codes (collectively "Company Identifiers") under which it operates when ComSouth has already been conducting business utilizing those Company Identifiers, ComSouth shall follow the Mergers and Acquisitions Process as described on BellSouth's Interconnection Web site, and shall be subject to separately negotiated rates, terms and conditions.
- 1.2.3 Tax Exemption. It is the responsibility of ComSouth to provide BellSouth with a properly completed tax exemption certificate in the current version of the form customarily used by BellSouth and at intervals required by the appropriate taxing authorities or reasonably requested by BellSouth. A tax exemption certificate must be supplied for each individual ComSouth entity purchasing Services under this Agreement. Upon BellSouth's receipt of a properly completed tax exemption certificate, subsequent billings to ComSouth will not include those taxes or fees from which ComSouth is exempt. Prior to receipt of a properly completed exemption certificate, BellSouth shall bill, and ComSouth shall pay all applicable taxes and fees. In the event that ComSouth believes that it is entitled to an exemption from and refund of taxes with respect to the amount billed prior to BellSouth's receipt of a properly completed exemption certificate, BellSouth shall assign to ComSouth its rights to claim a refund of such taxes. If applicable law prohibits the assignment of tax refund rights or requires the claim for refund of such taxes to be filed by BellSouth, BellSouth shall, after receiving a written request from ComSouth and at ComSouth's sole expense, pursue such refund claim on behalf of ComSouth, provided that ComSouth promptly reimburses BellSouth for any costs and expenses incurred by BellSouth in pursuing such refund claim; and, provided further, that BellSouth shall have the right to deduct any such outstanding costs and expenses from the amount of any refund obtained prior to remitting such refund to ComSouth or to deduct any such outstanding

costs and expenses from any amounts owed by BellSouth to ComSouth if no refund is obtained. ComSouth shall be solely responsible for the computation, tracking, reporting and payment of all taxes and fees associated with the services provided by ComSouth to its customers.

- 1.3 Deposit Policy. Prior to the inauguration of service or, thereafter, upon BellSouth's request, ComSouth shall complete the BellSouth Credit Profile (BellSouth form) and provide information to BellSouth regarding ComSouth's credit and financial condition. Based on BellSouth's analysis of the BellSouth Credit Profile and other relevant information regarding ComSouth's credit and financial condition, BellSouth reserves the right to require ComSouth to provide BellSouth with a suitable form of security deposit for ComSouth's account(s). If, in BellSouth's sole discretion, circumstances so warrant and/or ComSouth's gross monthly billing has increased, BellSouth reserves the right to request additional security (or to require a security deposit if none was previously requested) and/or file a Uniform Commercial Code (UCC-1) security interest in ComSouth's "accounts receivables and proceeds".
- 1.3.1 Security deposit shall take the form of cash, an irrevocable letter of credit (BellSouth form), surety bond (BellSouth form) or, in BellSouth's sole discretion, some other form of security proposed by ComSouth and accepted by BellSouth. Any such security deposit shall in no way release ComSouth from its obligation to make complete and timely payments of its bill(s). If BellSouth requires ComSouth to provide a security deposit, ComSouth shall provide such security deposit prior to the inauguration of service or within fifteen (15) days of BellSouth's request, as applicable. Security deposit request notices will be sent to ComSouth via certified mail or overnight delivery. Such notice period will start the day after the deposit request notice is rendered by certified mail or overnight delivery. Interest on a cash security deposit shall accrue and be applied or refunded in accordance with the terms in BellSouth's GSST.
- 1.3.2 Security deposits collected under this Section shall not exceed two (2) months' estimated billing for services pursuant to this Agreement. Estimated billings are calculated based upon the monthly average of the previous six (6) months current billings, if ComSouth has received service from BellSouth during such period at a level comparable to that anticipated to occur over the next six (6) months. If either ComSouth or BellSouth has reason to believe that the level of service to be received during the next six (6) months will be materially higher or lower than received in the previous six (6) months, ComSouth and BellSouth shall agree on a level of estimated billings based on all relevant information.
- 1.3.3 In the event ComSouth fails to provide BellSouth with a suitable form of security deposit or additional security deposit as required herein, defaults on its account(s), or otherwise fails to make any payment or payments required under this Agreement in the manner and within the time required, service to ComSouth may be Suspended, Discontinued or Terminated in accordance with the terms of

Section 1.5 below. Upon Termination of services, BellSouth shall apply any security deposit to ComSouth's final bill for its account(s). If no bill is rendered to ComSouth, BellSouth shall, nevertheless, apply any security deposit to ComSouth's outstanding balance.

- 1.3.3.1 At least seven (7) days prior to the expiration of any letter of credit provided by ComSouth as security under this Agreement, ComSouth shall renew such letter of credit or provide BellSouth with evidence that ComSouth has obtained a suitable replacement for the letter of credit. If ComSouth fails to comply with the foregoing, BellSouth shall thereafter be authorized, in its sole discretion, to draw down the full amount of such letter of credit and utilize the cash proceeds as security for ComSouth accounts(s). If ComSouth provides a security deposit or additional security deposit in the form of a surety bond as required herein, ComSouth shall renew the surety bond or provide BellSouth with evidence that ComSouth has obtained a suitable replacement for the surety bond at least seven (7) days prior to the cancellation date of the surety bond. If ComSouth fails to comply with the foregoing, BellSouth shall thereafter be authorized, in its sole discretion, to take action on the surety bond and utilize the cash proceeds as security for ComSouth's account(s). If the credit rating of any bonding company that has provided ComSouth with a surety bond provided as security hereunder has fallen below B, BellSouth will provide written notice to ComSouth that ComSouth must provide a replacement bond or other suitable security within fifteen (15) days of BellSouth's written notice. If ComSouth fails to comply with the foregoing, BellSouth shall thereafter be authorized, in its sole discretion, to take action on the surety bond and utilize the cash proceeds as security for ComSouth's account(s). Notwithstanding anything contained in this Agreement to the contrary, BellSouth shall be authorized, in its sole discretion, to draw down the full amount of any letter of credit or take action on any surety bond provided by ComSouth as security hereunder if ComSouth defaults on its account(s) or otherwise fails to make any payment or payments required under this Agreement in the manner and within the time, as required herein and apply the cash proceeds to any outstanding balance on ComSouth's accounts and utilize any remaining cash proceeds as security for ComSouth's account(s).

- 1.4 Payment Responsibility. Payment of all charges will be the responsibility of ComSouth. ComSouth shall pay invoices by utilizing wire transfer services or automatic clearing house services. ComSouth shall make payment to BellSouth for all services billed including disputed amounts. BellSouth will not become involved in billing disputes that may arise between ComSouth and ComSouth's customer.

- 1.4.1 Payment Due. Payment for services provided by BellSouth, including disputed charges, is due on or before the next bill date. Information required to apply payments must accompany the payment. The information must notify BellSouth of Billing Account Numbers (BAN) paid; invoices paid and the amount to be applied to each BAN and invoice (Remittance Information). Payment is considered to

have been made when the payment and Remittance Information are received by BellSouth. If the Remittance Information is not received with payment, BellSouth will be unable to apply amounts paid to ComSouth's accounts. In such event, BellSouth shall hold such funds until the Remittance Information is received. If BellSouth does not receive the Remittance Information by the payment due date for any account(s), late payment charges shall apply.

- 1.4.1.1 Due Dates. If the payment due date falls on a Sunday or on a holiday that is observed on a Monday, the payment due date shall be the first non-holiday day following such Sunday or holiday. If the payment due date falls on a Saturday or on a holiday which is observed on Tuesday, Wednesday, Thursday, or Friday, the payment due date shall be the last non-holiday day preceding such Saturday or holiday. If payment is not received by the payment due date, a late payment charge, as set forth in Section 1.4.1.2, below, shall apply.
- 1.4.1.2 Late Payment. If any portion of the payment is not received by BellSouth on or before the payment due date as set forth above, or if any portion of the payment is received by BellSouth in funds that are not immediately available to BellSouth, then a late payment and/or interest charge shall be due to BellSouth. The late payment and/or interest charge shall apply to the portion of the payment not received and shall be assessed as set forth in Section A2 of BellSouth's GSST, Section B2 of the Private Line Service Tariff or Section E2 of the BellSouth intrastate Access Services Tariff, or pursuant to the applicable state law as determined by BellSouth. In addition to any applicable late payment and/or interest charges, ComSouth may be charged a fee for all returned checks at the rate set forth in Section A2 of BellSouth's GSST or pursuant to the applicable state law.
- 1.5 Discontinuing Service to ComSouth. The procedures for discontinuing service to ComSouth are as follows:
- 1.5.1 In order of severity, Suspend/Suspension, Discontinue/Discontinuance and Terminate/Termination are defined as follows for the purposes of this Attachment:
- 1.5.1.1 Suspend/Suspension is the temporary restriction of the billed Party's access to the ordering systems and/or access to the billed Party's ability to initiate PIC-related changes. In addition, during Suspension, pending orders may not be completed and orders for new service or changes to existing services may not be accepted.
- 1.5.1.2 Discontinue/Discontinuance is the denial of service by the billing Party to the billed Party that will result in the disruption and discontinuation of service to the billed Party's customers. Additionally, at the time of Discontinuance, BellSouth will remove any Local Service Freezes in place on the billed Party's customers.
- 1.5.1.3 Terminate/Termination is the disconnection of service by the billing Party to the billed Party.

- 1.5.2 BellSouth reserves the right to Suspend, Discontinue or Terminate service in the event of prohibited, unlawful or improper use of BellSouth facilities or service, abuse of BellSouth facilities, or any other violation or noncompliance by ComSouth of the rules and regulations of BellSouth's tariffs.
- 1.5.3 Suspension. If payment of amounts due as described herein is not received by the bill date in the month after the original bill date, or fifteen (15) days from the date of a deposit request in the case of security deposits, BellSouth will provide written notice to ComSouth that services will be Suspended if payment of such amounts, and all other amounts that become past due before Suspension, is not received by wire transfer, automatic clearing house or cashier's check in the manner set forth in Section 1.4.1 above, or in the case of a security deposit request, in the manner set forth in Section 1.3.1 above: (1) within seven (7) days following such notice for CABS billed services; (2) within fifteen (15) days following such notice for CRIS and IBS billed services; and (3) within seven (7) days following such notice for security deposit requests.
- 1.5.3.1 The Suspension notice shall also provide that all past due charges for CRIS and IBS billed services, and all other amounts that become past due for such services before Discontinuance, must be paid within thirty (30) days from the date of the Suspension notice to avoid Discontinuance of CRIS and IBS billed services.
- 1.5.3.2 For CABS billed services, BellSouth will provide a Discontinuance notice that is separate from the Suspension notice, that all past due charges for CABS billed Services, and all other amounts that become past due for such services before Discontinuance, must be paid within thirty (30) days from the date of the Suspension notice to avoid Discontinuance of CABS billed services. This Discontinuance notice may be provided at the same time that BellSouth provides the Suspension notice.
- 1.5.4 Discontinuance. If payment of amounts due as described herein is not received by the bill date in the month after the original bill date, BellSouth will provide written notice that BellSouth may Discontinue the provision of existing services to ComSouth if payment of such amounts, and all other amounts that become past due before Discontinuance, including requested security deposits, is not received by wire transfer, automatic clearing house or cashier's check in the manner set forth in Section 1.4.1 above or in the case of a deposit in accordance with Section 1.3.1 above, within thirty (30) days following such written notice; provided, however, that BellSouth may provide written notice that such existing services may be Discontinued within fifteen (15) days following such notice, subject to the criteria described in Section 1.5.4.1 below.
- 1.5.4.1 BellSouth may take the action to Discontinue the provision of existing service upon fifteen (15) days from the day after BellSouth provides written notice of such Discontinuance if (a) such notice is sent by certified mail or overnight delivery; (b) ComSouth has not paid all amounts due pursuant to a subject bill(s), or has not provided adequate security pursuant to a deposit request; and (c) either:

(1) BellSouth has sent the subject bill(s) to ComSouth within seven (7) business days of the bill date(s), verifiable by records maintained by BellSouth:

- i. in paper or CDROM form via the United States Postal Service (USPS), or
- ii. in magnetic tape form via overnight delivery, or
- iii. via electronic transmission; or

(2) BellSouth has sent the subject bill(s) to ComSouth, using one of the media described in (1) above, more than thirty (30) days before notice to Discontinue service has been rendered.

1.5.4.2 In the case of Discontinuance of services, all billed charges, as well as applicable disconnect charges, shall become due.

1.5.4.3 ComSouth is solely responsible for notifying the customer of the Discontinuance of service. If, within seven (7) days after ComSouth's services have been Discontinued, ComSouth pays, by wire transfer, automatic clearing house or cashier's check, all past due charges, including late payment charges, outstanding security deposit request amounts if applicable and any applicable restoral charges as set forth in Section A4 of BellSouth's GSST, then BellSouth will reestablish service for ComSouth.

1.5.5 Termination. If within seven (7) days after ComSouth's service has been Discontinued and ComSouth has failed to pay all past due charges as described above, then ComSouth's service will be Terminated.

2. Billing Disputes

2.1 ComSouth shall electronically submit all billing disputes to BellSouth using the form specified by BellSouth. In the event of a billing dispute, the Parties will endeavor to resolve the dispute within sixty (60) days of the notification date. Within five (5) business days of BellSouth's denial, or partial denial, of the billing dispute, if ComSouth is not satisfied with BellSouth's resolution of the billing dispute or if no response to the billing dispute has been received by ComSouth by such sixtieth (60th) day, ComSouth must pursue the escalation process as outlined in the Billing Dispute Escalation Matrix, set forth on BellSouth's Interconnection Services Web site, or the billing dispute shall be considered denied and closed. If, after escalation, the Parties are unable to reach resolution, then the aggrieved Party, if it elects to pursue the dispute shall pursue dispute resolution in accordance with General Terms and Conditions.

2.2 For purposes of this Section 2, a billing dispute means a reported dispute submitted pursuant to Section 2.1 above of a specific amount of money actually billed by BellSouth within twelve (12) months of the submission of such dispute. ComSouth agrees to not submit billing disputes for amounts billed more than

twelve (12) months prior to submission of a billing dispute filed for amounts billed. The billing dispute must be clearly explained by ComSouth and supported by written documentation, which clearly shows the basis for disputing charges. The determination as to whether the billing dispute is clearly explained or clearly shows the basis for disputing charges shall be within BellSouth's sole reasonable discretion. Disputes that are not clearly explained or those that do not provide complete information may be rejected by BellSouth. Claims by ComSouth for damages of any kind will not be considered a billing dispute for purposes of this Section. If BellSouth resolves the billing dispute, in whole or in part, in favor of ComSouth, any credits and interest due to ComSouth as a result thereof shall be applied to ComSouth's account by BellSouth upon resolution of the billing dispute.

3. Non-InterCompany Settlements

- 3.1 Direct Participants are Telecommunications carriers that exchange data directly with other Direct Participants via the Centralized Message Distribution System (CMDS) Data Center (Direct Participant) and may act as host companies (Host) for those Telecommunications carriers that do not exchange data directly via the CMDS Data Center.
- 3.2 The Non-InterCompany Settlements (NICS) is the national system administered by Telcordia that is used in the settlement of revenues for calls that are originated and billed by two (2) different local exchange carriers (LEC) within a single Direct Participant's territory to another for billing. NICS applies to calls involving another LEC where the Earning Company and the Billing Company are located within BellSouth's territory.
- 3.3 In association with message distribution service, BellSouth will provide ComSouth with associated intercompany settlements reports as appropriate.
- 3.4 Notwithstanding anything in this Agreement to the contrary, in no case shall either Party be liable to the other for any direct or consequential damages incurred as a result of the obligations set out in this Section 3.
- 3.5 Intercompany Settlements Messages
- 3.5.1 Intercompany Settlements Messages facilitate the settlement of revenues associated with traffic originated from or billed by ComSouth as a facilities based provider of local exchange Telecommunications Services.
- 3.5.2 BellSouth will receive the monthly NICS reports from Telcordia on behalf of ComSouth and will distribute copies of these reports to ComSouth on a monthly basis.
- 3.5.3 Through NICS, BellSouth will collect the revenue earned by ComSouth within the BellSouth territory from another LEC also within the BellSouth territory where the

messages are billed, less a per message billing and collection fee of five cents (\$0.05), on behalf of ComSouth. BellSouth will remit the revenue billed by ComSouth within the BellSouth region to the LEC also within the BellSouth region, where the messages originated, less a per message billing and collection fee of five cents (\$0.05). These two (2) amounts will be netted together by BellSouth and the resulting charge or credit issued to ComSouth via a CABS miscellaneous bill on a monthly basis in arrears.

- 3.5.4 BellSouth and ComSouth agree that monthly netted amounts of less than fifty dollars (\$50.00) will not be settled.

Attachment 8

Rights-of-Way, Conduits and Pole Attachments

Rights-of-Way, Conduits and Pole Attachments

BellSouth will provide nondiscriminatory access to any pole, duct, conduit, or right-of-way owned or controlled by BellSouth pursuant to 47 U.S.C. § 224, as amended by the Act, pursuant to terms and conditions of a separate license agreement negotiated with BellSouth.

Attachment 9
Service Quality Measurements

SERVICE QUALITY MEASUREMENTS

Upon a particular Commission's issuance of an order pertaining to Service Quality Measurements in a proceeding expressly applicable to all CLECs generally, BellSouth shall implement in that state such Service Quality Measurements as of the date specified by the Commission. Service Quality Measurements that have been ordered in a particular state can currently be accessed via the internet at <http://pmap.bellsouth.com>.

Attachment 10

BellSouth Disaster Recovery Plan

CONTENTS



PAGE

1.0	Purpose	2
2.0	Single Point of Contact	2
3.0	Identifying the Problem	2
3.1	Site Control	3
3.2	Environmental Concerns	4
4.0	The Emergency Control Center (ECC)	4
5.0	Recovery Procedures	5
5.1	CLEC Outage	5
5.2	BellSouth Outage	5
5.2.1	Loss of Central Office	6
5.2.2	Loss of a Central Office with Serving Wire Center Functions	6
5.2.3	Loss of a Central Office with Tandem Functions	6
5.2.4	Loss of a Facility Hub	7
5.3	Combined Outage (CLEC and BellSouth Equipment)	7
6.0	T1 Identification Procedures	7
7.0	Acronyms	8

1.0 PURPOSE

In the unlikely event of a disaster occurring that affects BellSouth's long-term ability to deliver traffic to a CLEC, general procedures have been developed by BellSouth to hasten the recovery process in accordance with the Telecommunications Service Priority (TSP) Program established by the FCC to identify and prioritize telecommunication services that support national security or emergency preparedness (NS/EP) missions. A description of the TSP Program as it may be amended from time to time is available on BellSouth's Interconnection Services Web site. Since each location is different and could be affected by an assortment of potential problems, a detailed recovery plan is impractical. However, in the process of reviewing recovery activities for specific locations, some basic procedures emerge that appear to be common in most cases.

These general procedures should apply to any disaster that affects the delivery of traffic for an extended time period. Each CLEC will be given the same consideration during an outage, and service will be restored as quickly as possible.

This document will cover the basic recovery procedures that would apply to every CLEC.

2.0 SINGLE POINT OF CONTACT

When a problem is experienced, regardless of the severity, the BellSouth Network Management Center (NMC) will observe traffic anomalies and begin monitoring the situation. Controls will be appropriately applied to insure the sanity of BellSouth's network; and, in the event that a switch or facility node is lost, the NMC will attempt to circumvent the failure using available reroutes.

BellSouth's NMC will remain in control of the restoration efforts until the problem has been identified as being a long-term outage. At that time, the NMC will contact BellSouth's ECC and relinquish control of the recovery efforts. Even though the ECC may take charge of the situation, the NMC will continue to monitor the circumstances and restore traffic as soon as damaged network elements are revitalized.

The telephone number for the BellSouth Network Management Center in Atlanta, as published in Telcordia's National Network Management Directory, is 404-321-2516.

3.0 IDENTIFYING THE PROBLEM

During the early stages of problem detection, the NMC will be able to tell which CLECs are affected by the catastrophe. Further analysis and/or first hand observation will determine if the disaster has affected CLEC equipment only, BellSouth equipment only or a combination. The initial restoration activity will be largely determined by the equipment that is affected.

Once the nature of the disaster is determined and after verifying the cause of the problem, the NMC will initiate reroutes and/or transfers that are jointly agreed upon by the affected CLECs' Network Management Center and the BellSouth NMC. The type and percentage of controls used will depend upon available network capacity. Controls necessary to stabilize the situation will be invoked and the NMC will attempt to re-establish as much traffic as possible.

For long-term outages, recovery efforts will be coordinated by the ECC. Traffic controls will continue to be applied by the NMC until facilities are re-established. As equipment is made available for service, the ECC will instruct the NMC to begin removing the controls and allow traffic to resume.

3.1 SITE CONTROL

In the total loss of building use scenario, what likely exists will be a smoking pile of rubble. This rubble will contain many components that could be dangerous. It could also contain any personnel on the premises at the time of the disaster. For these reasons, the local fire marshal with the assistance of the police will control the site until the building is no longer a threat to surrounding properties and the companies have secured the site from the general public.

During this time, the majority owner of the building should be arranging for a demolition contractor to mobilize to the site with the primary objective of reaching the cable entrance facility for a damage assessment. The results of this assessment would then dictate immediate plans for restoration, both short term and permanent.

In a less catastrophic event, i.e., the building is still standing and the cable entrance facility is usable, the situation is more complex. The site will initially be controlled by local authorities until the threat to adjacent property has diminished. Once the site is returned to the control of the companies, the following events should occur.

An initial assessment of the main building infrastructure systems (mechanical, electrical, fire and life safety, elevators, and others) will establish building needs. Once these needs are determined, the majority owner should lead the building restoration efforts. There may be situations where the site will not be totally restored within the confines of the building. The companies must individually determine their needs and jointly assess the cost of permanent restoration to determine the overall plan of action.

Multiple restoration trailers from each company will result in the need for designated space and installation order. This layout and control is required to maximize the amount of restoration equipment that can be placed at the site, and the priority of placements.

Care must be taken in this planning to ensure other restoration efforts have logistical access to the building. Major components of telephone and building equipment will need to be removed and replaced. A priority for this equipment must also be jointly established to facilitate overall site restoration. (Example: If the AC switchgear has sustained damage, this would be of the highest priority in order to regain power, lighting, and HVAC throughout the building.)

If the site will not accommodate the required restoration equipment, the companies would then need to quickly arrange with local authorities for street closures, rights of way or other possible options available.

3.2 ENVIRONMENTAL CONCERNS

In the worse case scenario, many environmental concerns must be addressed. Along with the police and fire marshal, the state environmental protection department will be on site to monitor the situation.

Items to be concerned with in a large central office building could include:

1. Emergency engine fuel supply. Damage to the standby equipment and the fuel handling equipment could have created "spill" conditions that have to be handled within state and federal regulations.
2. Asbestos-containing materials that may be spread throughout the wreckage. Asbestos could be in many components of building, electrical, mechanical, outside plant distribution, and telephone systems.
3. Lead and acid. These materials could be present in potentially large quantities depending upon the extent of damage to the power room.
4. Mercury and other regulated compounds resident in telephone equipment.
5. Other compounds produced by the fire or heat.

Once a total loss event occurs at a large site, local authorities will control immediate clean up (water placed on the wreckage by the fire department) and site access.

At some point, the companies will become involved with local authorities in the overall planning associated with site clean up and restoration. Depending on the clean up approach taken, delays in the restoration of several hours to several days may occur.

In a less severe disaster, items listed above are more defined and can be addressed individually depending on the damage.

In each case, the majority owner should coordinate building and environmental restoration as well as maintain proper planning and site control.

4.0 THE ECC

The ECC is located in the Midtown 1 Building in Atlanta, Georgia. During an emergency, the ECC staff will convene a group of pre-selected experts to inventory the damage and initiate corrective actions. These experts have regional access to BellSouth's personnel and equipment and will assume control of the restoration activity anywhere in the nine-state area.

In the past, the ECC has been involved with restoration activities resulting from hurricanes, ice storms and floods. They have demonstrated their capabilities during these calamities as well as

during outages caused by human error or equipment failures. This group has an excellent record of restoring service as quickly as possible.

During a major disaster, the ECC may move emergency equipment to the affected location, direct recovery efforts of local personnel and coordinate service restoration activities with the CLECs. The ECC will attempt to restore service as quickly as possible using whatever means is available, leaving permanent solutions, such as the replacement of damaged buildings or equipment, for local personnel to administer.

Part of the ECC's responsibility, after temporary equipment is in place, is to support the NMC efforts to return service to the CLECs. Once service has been restored, the ECC will return control of the network to normal operational organizations. Any long-term changes required after service is restored will be made in an orderly fashion and will be conducted as normal activity.

5.0 RECOVERY PROCEDURES

The nature and severity of any disaster will influence the recovery procedures. One crucial factor in determining how BellSouth will proceed with restoration is whether or not BellSouth's equipment is incapacitated. Regardless of whose equipment is out of service, BellSouth will move as quickly as possible to aid with service recovery; however, the approach that will be taken may differ depending upon the location of the problem.

5.1 CLEC OUTAGE

For a problem limited to one CLEC (or a building with multiple CLECs), BellSouth has several options available for restoring service quickly. For those CLECs that have agreements with other CLECs, BellSouth can immediately start directing traffic to a provisional CLEC for completion. This alternative is dependent upon BellSouth having concurrence from the affected CLECs.

Whether or not the affected CLECs have requested a traffic transfer to another CLEC will not impact BellSouth's resolve to re-establish traffic to the original destination as quickly as possible.

5.2 BELLSOUTH OUTAGE

Because BellSouth's equipment has varying degrees of impact on the service provided to the CLECs, restoring service from damaged BellSouth equipment is different. The outage will probably impact a number of Carriers simultaneously. However, the ECC will be able to initiate immediate actions to correct the problem.

A disaster involving any of BellSouth's equipment locations could impact the CLECs, some more than others. A disaster at a Central Office (CO) would only impact the delivery of traffic to and from that one location, but the incident could affect many Carriers. If the CO is a Serving Wire Center (SWC), then traffic from the entire area to those Carriers served from that switch would also be impacted. If the switch functions as an Access Tandem, or there is a tandem in the building, traffic from every CO to every CLEC could be interrupted. A disaster that destroys a facility hub could disrupt various traffic flows, even though the switching equipment may be unaffected.

The NMC would be the first group to observe a problem involving BellSouth's equipment. Shortly after a disaster, the NMC will begin applying controls and finding re-routes for the completion of as much traffic as possible. These reroutes may involve delivering traffic to alternate Carriers upon receiving approval from the CLECs involved. In some cases, changes in translations will be required. If the outage is caused by the destruction of equipment, then the ECC will assume control of the restoration.

5.2.1 Loss of a CO

When BellSouth loses a CO, the ECC will

- a) Place specialists and emergency equipment on notice;
- b) Inventory the damage to determine what equipment and/or functions are lost;
- c) Move containerized emergency equipment and facility equipment to the stricken area, if necessary;
- d) Begin reconnecting service on a parity basis for Hospitals, Police and other emergency agencies or customers served by BellSouth or CLEC in accordance with the TSP priority restoration coding scheme entered in the BellSouth Maintenance database prior to the emergency.

5.2.2 Loss of a CO with SWC Functions

The loss of a CO that also serves as a SWC will be restored as described in Section 5.2.1.

5.2.3 Loss of a CO with Tandem Functions

When BellSouth loses a CO building that serves as an Access Tandem and as a SWC, the ECC will

- a) Place specialists and emergency equipment on notice;
- b) Inventory the damage to determine what equipment and/or functions are lost;
- c) Move containerized emergency equipment and facility equipment to the stricken area, if necessary;
- d) Begin reconnecting service on a parity basis for Hospitals, Police and other emergency agencies or customers served by BellSouth or CLEC in accordance with the TSP priority restoration coding scheme entered in the BellSouth Maintenance database prior to the emergency;
- e) Re-direct as much traffic as possible to the alternate access tandem (if available) for delivery to those CLECs utilizing a different location as a SWC;
- f) Begin aggregating traffic to a location near the damaged building. From this location, begin re-establishing trunk groups to the CLECs for the delivery of traffic normally

found on the direct trunk groups. (This aggregation point may be the alternate access tandem location or another CO on a primary facility route.)

5.2.4 Loss of a Facility Hub

In the event that BellSouth loses a facility hub, the recovery process is much the same as above. Once the NMC has observed the problem and administered the appropriate controls, the ECC will assume authority for the repairs. The recovery effort will include

- a) Placing specialists and emergency equipment on notice;
- b) Inventorying the damage to determine what equipment and/or functions are lost;
- c) Moving containerized emergency equipment to the stricken area, if necessary;
- d) Reconnecting service on a parity basis for Hospitals, Police and other emergency agencies or customers served by BellSouth or CLEC in accordance with the TSP priority restoration coding scheme entered in the BellSouth Maintenance database prior to the emergency; and
- e) If necessary, BellSouth will aggregate the traffic at another location and build temporary facilities. This alternative would be viable for a location that is destroyed and building repairs are required.

5.3 COMBINED OUTAGE (CLEC AND BELLSOUTH EQUIPMENT)

In some instances, a disaster may impact BellSouth's equipment as well as the CLECs'. This situation will be handled in much the same way as described in Section 5.2.3. Since BellSouth and the CLECs will be utilizing temporary equipment, close coordination will be required.

6.0 T1 IDENTIFICATION PROCEDURES

During the restoration of service after a disaster, BellSouth may be forced to aggregate traffic for delivery to a CLEC. During this process, T1 traffic may be consolidated onto DS3s and may become unidentifiable to the Carrier. Because resources will be limited, BellSouth may be forced to "package" this traffic entirely differently than normally received by the CLECs. Therefore, a method for identifying the T1 traffic on the DS3s and providing the information to the Carriers is required.

7.0 ACRONYMS

CLEC	-	Competitive Local Exchange Carrier
CO	-	Central Office (BellSouth)
DS3	-	Facility that carries 28 T1s (672 circuits)
ECC	-	Emergency Control Center (BellSouth)
NMC	-	Network Management Center
SWC	-	Serving Wire Center (BellSouth switch)
T1	-	Facility that carries 24 circuits
TSP	-	Telecommunications Service Priority

Hurricane Information

During a hurricane, BellSouth will make every effort to keep CLECs updated on the status of our network. Information centers will be set up throughout BellSouth Telecommunications. These centers are not intended to be used for escalations, but rather to keep the CLEC informed of network related issues, area damages and dispatch conditions, etc.

Hurricane-related information can also be found on BellSouth's Interconnection Web site by clicking on the link "Relief Information" in the special alert box located on the Web page. Additionally, information concerning Mechanized Disaster Reports can also be found by clicking on the link "Click here for information concerning Disaster Recovery Reports" on the Hurricane Relief page.

BST Disaster Management Plan

BellSouth maintenance centers have geographical and redundant communication capabilities. In the event of a disaster removing any maintenance center from service another geographical center would assume maintenance responsibilities. The contact numbers will not change and the transfer will be transparent to the CLEC.

Attachment 11

Bona Fide Request and New Business Request Process

BONA FIDE REQUEST AND NEW BUSINESS REQUEST PROCESS

1. **Bona Fide Request**
- 1.1 The Parties agree that ComSouth is entitled to order any Network Element, interconnection option or service option required to be made available by FCC or Commission requirements pursuant to the Act. A Bona Fide Request (BFR) is to be used when ComSouth makes a request of BellSouth to provide a new or modified Network Element, interconnection option or other service option pursuant to the Act that was not previously provided for in this Agreement.
- 1.2 A BFR shall be submitted in writing by ComSouth and shall specifically identify the requested service date, technical requirements, space requirements and/or such other specifications that clearly define the request such that BellSouth has sufficient information to analyze and prepare a response. Such a request shall also include ComSouth's designation of the request as being pursuant to the Telecommunications Act of 1996 (i.e., a BFR). The request shall be sent to ComSouth's designated BellSouth Sales contact or Local Contract Manager (LCM).
- 1.3 Within two (2) business days of receipt of a BFR, BellSouth shall acknowledge in writing its receipt and identify a single point of contact responsible for responding to the BFR and shall request any additional information needed to process the request to the extent known at that time. Notwithstanding the foregoing, BellSouth may reasonably request additional information from ComSouth at any time during the processing of the BFR.
- 1.4 Within thirty (30) business days of BellSouth's receipt of the BFR, if the preliminary analysis of the requested BFR is not of such complexity that it will cause BellSouth to expend extraordinary resources to evaluate the BFR, BellSouth shall respond to ComSouth by providing a preliminary analysis of the new or modified Network Element or interconnection option not ordered by the FCC or Commission that is the subject of the BFR. The preliminary analysis shall either confirm that BellSouth will offer access to the new or modified Network Element, interconnection option or service option or confirm that BellSouth will not offer the new or modified Network Element, interconnection option or service option.
- 1.5 For any new or modified Network Element, interconnection option or service option not ordered by the FCC or Commission, if the preliminary analysis states that BellSouth will offer the new or modified Network Element, interconnection option or service option, the preliminary analysis will include an estimate of the costs of utilizing existing resources, both personnel and systems, in the development including, but not limited to,

request parameters analysis, determination of impacted BellSouth departments, determination of required resources, project management resources, etc. (Development Rate) including a general breakdown of such costs associated with the Network Element, interconnection option or service option and the date the request can be met. If the preliminary analysis states that BellSouth will not offer the new or modified Network Element, interconnection option or service option, BellSouth will provide an explanation of why the request is not technically feasible, does not qualify as a BFR for the new or modified Network Element, interconnection option or service option, should actually be submitted as a New Business Request (NBR) or is otherwise not required to be provided under the Act. If BellSouth cannot provide the Network Element, interconnection option or service option by the requested date, BellSouth shall provide an alternative proposed date together with a detailed explanation as to why BellSouth is not able to meet ComSouth's requested date.

- 1.6 For any new or modified Network Element, interconnection option or service option not ordered by the FCC or Commission, if BellSouth determines that the preliminary analysis of the requested BFR is of such complexity that it will cause BellSouth to expend extraordinary resources to evaluate the BFR, BellSouth shall notify ComSouth within ten (10) business days of BellSouth's receipt of BFR that a fee will be required prior to the preliminary evaluation of the BFR. Such fee shall be limited to BellSouth's extraordinary expenses directly related to the complex request that require the allocation and engagement of additional resources above the existing allocated resources used on BFR cost development which include, but are not limited to, expenditure of funds to develop feasibility studies, specific resources that are required to determine request requirements (such as operation support system analysts, technical managers, software developers), software impact analysis by specific software developers; software architecture development, hardware impact analysis by specific system analysts, etc. and the request for such fee shall be accompanied with a general breakdown of such costs. If ComSouth accepts the complex request evaluation fee proposed by BellSouth, ComSouth shall submit such fee within thirty (30) business days of BellSouth's notice that a complex request evaluation fee is required. Within thirty (30) business days of BellSouth's receipt of the complex request evaluation fee, BellSouth shall respond to ComSouth by providing a preliminary analysis, consistent with Section 1.4 above.
- 1.7 ComSouth may cancel a BFR at any time up until thirty (30) business days after receiving BellSouth's preliminary analysis. If ComSouth cancels the BFR within thirty (30) business days after receipt of BellSouth's preliminary analysis, BellSouth shall be entitled to keep any complex request evaluation fee submitted in accordance with Section 1.6 above,

minus those costs included in the fee that have not been incurred as of the date of cancellation.

- 1.8 ComSouth will have thirty (30) business days from receipt of preliminary analysis to accept the preliminary analysis or cancel the BFR. If ComSouth fails to respond within this thirty (30) business day period, the BFR will be deemed cancelled. Acceptance of the preliminary analysis must be in writing and accompanied by the estimated Development Rate for the new or modified Network Element, interconnection option or service option quoted in the preliminary analysis.
- 1.9 Notwithstanding any other provision of this Agreement, BellSouth shall propose a firm price quote, including the firm Development Rate, the firm nonrecurring rate and the firm recurring rate, and a detailed implementation plan within ten (10) business days of receipt of ComSouth's accurate BFR application for a Network Element, interconnection option or service option that is operational at the time of the request; thirty (30) business days of receipt of ComSouth's accurate BFR application for a new or modified Network Element, interconnection option or service option ordered by the FCC or Commission; and within sixty (60) business days of receipt of ComSouth's accurate BFR application for a new or modified Network Element, interconnection option or service option not ordered by the FCC or Commission or not operational at the time of the request. The firm nonrecurring rate will not include any of the Development Rate or the complex request evaluation fee, if required, in the calculation of this rate. Such firm price quote shall not exceed the estimate provided with the preliminary analysis by more than twenty-five percent (25%).
- 1.10 ComSouth shall have thirty (30) business days from receipt of firm price quote to accept or deny the firm price quote and submit any additional Development or nonrecurring rates quoted in the firm price quote.
- 1.11 Unless ComSouth agrees otherwise, all prices shall be consistent with the applicable pricing principles and provisions of the Act.
- 1.12 If ComSouth believes that BellSouth's firm price quote is not consistent with the requirements of the Act, either Party may seek dispute resolution in accordance with the dispute resolution provisions set forth in General Terms and Conditions.
- 1.13 Upon agreement to the rates, terms and conditions of a BFR, the Parties shall negotiate in good faith an amendment to this Agreement.

2 New Business Request

- 2.1 ComSouth also shall be permitted to request the development of new or modified facilities or service options which may not be required by the Act. Procedures applicable to requesting the addition of such elements, services and options are specified in this Attachment. A NBR is to be used by ComSouth to make a request of BellSouth for a new or modified feature or capability of an existing product or service, a new product or service that is not deployed within the BellSouth network or operations and business support systems, or a new or modified service option that was not previously included in this Agreement (Requested NBR Services) and is not required by the Act.
- 2.2 An NBR shall be submitted in writing by ComSouth and shall specifically identify the requested service date, technical requirements, space requirements and/or such specifications that clearly define the request such that BellSouth has sufficient information to analyze and prepare a response. The request shall be sent to ComSouth's designated BellSouth Sales contact or LCM.
- 2.3 Within two (2) business days of receipt of an NBR, BellSouth shall acknowledge in writing its receipt and identify a single point of contact responsible for responding to the NBR and shall request any additional information needed to process the request to the extent known at that time. Notwithstanding the foregoing, BellSouth may reasonably request additional information from ComSouth at any time during the processing of the NBR.
- 2.4 If the preliminary analysis of the requested NBR is not of such complexity that it will cause BellSouth to expend extraordinary resources to evaluate the NBR, within thirty (30) business days of its receipt of the NBR, BellSouth shall respond to ComSouth by providing a preliminary analysis of such Requested NBR Services that are the subject of the NBR. The preliminary analysis shall either confirm that BellSouth will offer access to the Requested NBR Services or confirm that BellSouth will not offer the Requested NBR Services.
- 2.5 If the preliminary analysis states that BellSouth will offer the Requested NBR Services, the preliminary analysis will include an estimate of the Development Rate including a general breakdown of costs and the date the request can be met. If BellSouth cannot provide the Requested NBR Service by the requested date, it shall provide an alternative proposed date together with a detailed explanation as to why BellSouth is not able to meet ComSouth's requested date.
- 2.6 If BellSouth determines that the preliminary analysis of the requested NBR is of such complexity that it will cause BellSouth to expend extraordinary resources to evaluate the NBR, BellSouth shall notify

ComSouth within ten (10) business days of BellSouth's notice that a complex request evaluation fee is required prior to the evaluation of the NBR. Such fee shall be limited to BellSouth's extraordinary expenses directly related to the complex request. If ComSouth accepts the complex request evaluation fee amount proposed by BellSouth, ComSouth shall submit such complex request evaluation fee within thirty (30) business days of BellSouth's notice that a complex request evaluation fee is required.

- 2.7 Within thirty (30) business days of BellSouth's receipt of the complex request evaluation fee, BellSouth shall respond to ComSouth by providing a preliminary analysis of such Requested NBR Services.
- 2.8 ComSouth may cancel an NBR at any time. If ComSouth cancels the request more than ten (10) business days after submitting it, ComSouth shall pay BellSouth's reasonable and demonstrable costs of processing and/or implementing the NBR up to the date of cancellation in addition to any fee submitted in accordance with Section 1.6 above.
- 2.9 ComSouth will have thirty (30) business days from receipt of the preliminary analysis to accept the preliminary analysis or cancel the NBR. If ComSouth fails to respond within this thirty (30) business day period, the NBR will be deemed cancelled.
- 2.10 Acceptance of the preliminary analysis must be in writing and accompanied by the estimated Development Rate for the Requested NBR Services quoted in the preliminary analysis.
- 2.11 BellSouth shall propose a firm price quote including the firm Development Rate, the firm nonrecurring rate, and the firm recurring rate, and a detailed implementation plan within ten (10) business days of receipt of ComSouth's accurate NBR application for a Requested NBR Service that is operational at the time of the request and within sixty (60) business days of receipt of ComSouth's accurate NBR application for the Requested NBR Services not operational at the time of the request. The firm nonrecurring rate will not include any of the Development Rate or the complex request evaluation fee, if required, in the calculation of this rate. Such firm price quote shall not exceed the estimate provided with the preliminary analysis by more than twenty-five percent (25%).
- 2.12 ComSouth shall have thirty (30) business days from receipt of the firm price quote to accept or deny the firm price quote and submit any additional nonrecurring, non-refundable fees quoted in the firm price quote. If the firm price quote is less than the preliminary analysis' estimate of the Development Rate, BellSouth will credit ComSouth's account for the difference.

- 2.13 Upon agreement to the rates, terms and conditions of a NBR, an amendment to this Agreement, or a separate agreement, may be required and the Parties shall negotiate such agreement or amendment in good faith.